

## Eulerian Description of Rail Straightening Process

Tomas NAVRAT<sup>1,a</sup> and Jindrich PETRUSKA<sup>1,b</sup>

<sup>1</sup>Brno University of Technology, Faculty of Mech.Engineering,  
Technicka 2, 616 69 Brno, Czech Republic

<sup>a</sup>navrat@fme.vutbr.cz, <sup>b</sup>petruska@fme.vutbr.cz

**Keywords:** Straightening process, FEM, Elasto-plastic bending, Eulerian description.

**Abstract.** The paper deals with numerical analysis of the process of roller straightening of rails. The problem of repeated elasto-plastic bending is solved by a program in MATLAB based on FEM algorithm with Eulerian description of material flow through the straightening machine. Beam element formulation with a shear deformation effect is used for the rail discretization. The results are compared with literature and standard FE analysis with Lagrangian description of material flow. Effectiveness of presented formulation is discussed and its applicability for fast iterative optimization of the straightening process is illustrated.

### Introduction

Straightening of long products by repeated elasto-plastic bending is a standard procedure which should result in redistribution of residual stress and minimization of final curvature of the products like rolled sections, wires or rails. Relation between intermeshing of straightening rollers, parameters of the straightened product and final impact of the process is not trivial. It has been a topic of intensive research for many years. First effective models to solve this problem were based on empirical experience combined with elementary analytical approaches [1,2].

With the development of FEM and increased computer power which enables to solve nonlinear problems effectively, more complicated models were formulated and many phenomena of the leveling process could be investigated computationally. Direct solution of elasto-plastic stress and strain history in the cross section of straightened product is a real possibility now. Nevertheless, this approach is still limited by capacity and time demands of large numerical simulations and many simplifying assumptions must be accepted. In the area of rail straightening this can be documented by Refs. [3-7]. The simplifications relate to many aspects like neglecting the rail movement through the straightening machine, contact stress between rail and rollers or accepting different levels of stress state modeling from simple 1D beam models up to full 3D simulation. Another source of variability is caused by different levels of material modeling. Typically, several levels of such models are created and the solution of real problem is found iterating among these different levels [3,5,7].

Another approach is based on the integration of curvature of the leveled product [8]. This can be seen as an inverse problem solution, starting from the suggestion of sequence of bending curvatures on each roller, which comes often from experience. The process of curvature integration is then repeated in successive iterations to reach optimal distribution of roll intermeshing, loading, bending moments, residual stress and final curvature of the product.

Looking for an effective optimization tool, we suggest a direct approach, starting from the roll intermeshing as in [3-7]. Efficiency of this approach is secured by application of Eulerian description of material flow through the straightening machine. Fast algorithm is then used to evaluate curvature, bending moments and roll loadings along the straightened bar together with full stress/strain history in each material point, residual stress distribution and final curvature. The program is based on FEM using a locking-free shear deformable beam element [9]. With fast and reliable solution of the direct problem, optimal setting of the leveling rolls can be found in an iterative process. In the paper we present suggested algorithm and our experience with its stability and general efficiency.

### Basic Assumptions and Straightening Algorithm

In Fig.1 we show schematic representation of the 9-roller straightening machine. We suppose the UIC60 (60 kg/m) rail with cross section according to Fig.2 entering the machine from the left side. Its deflection, slope, curvature and stress distribution can be described by shear deformable beam theory according to [9]. Bottom rollers are vertically fixed, whereas the four top rollers are adjustable to obtain optimal bending to straighten the product.

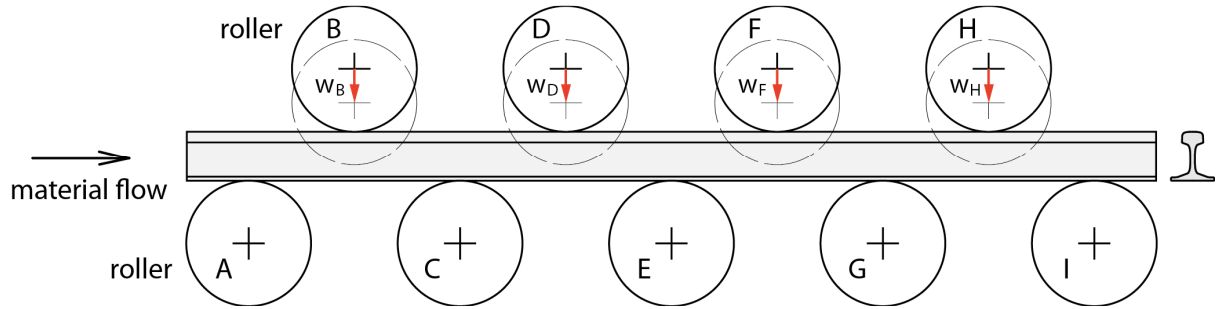

Fig. 1 Schematic representation of the straightening process

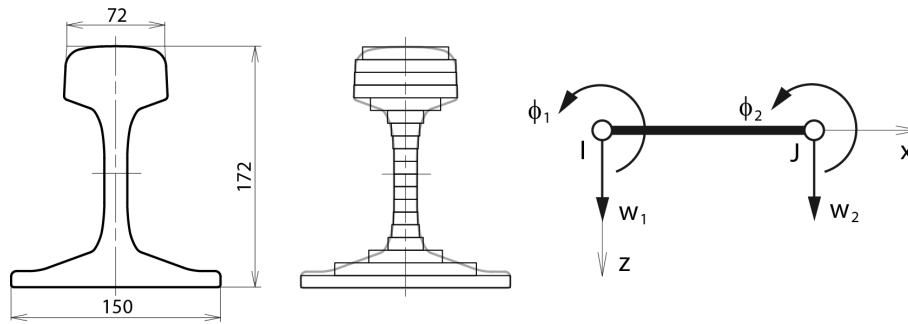

Fig. 2 Cross section of the UIC60 rail and beam element.

We also suppose simple point contact between the rollers and the rail. Input parameters are represented by the beam cross section, input curvature and by positions of the adjustable rollers. Material model is characterized by bilinear flow curve with linear hardening diagram, von Mises criterion of plasticity and kinematic hardening rule. Output parameters are the deflection, slope and curvature along the beam, distribution of bending moments, shear forces and roller reactions and distribution of longitudinal elastic plastic stress in any cross section along the beam, including residual stress and curvature at the end.

### Basic Equations and Solution Algorithm

The algorithm is based on iterative solution of a linearized equation

$$\mathbf{K}_{T,i-1} \cdot \Delta \mathbf{U}_i = \mathbf{R}_{i-1}, \quad (1)$$

$$\mathbf{U}_i = \mathbf{U}_{i-1} + \Delta \mathbf{U}_i, \quad (2)$$

Where  $\mathbf{R}$  is a matrix of residual nodal shear forces and bending moments and  $\mathbf{K}_T$  is tangential stiffness matrix composed of 2-node FE beam elements (Fig. 2) with two DOF – deflection  $w$  and rotation  $\phi$  – in each node with different approximation of both [9]:

$$\begin{bmatrix} w(x) \\ \phi(x) \end{bmatrix} = \begin{bmatrix} N_1^{(1)} & N_2^{(1)} & N_3^{(1)} & N_4^{(1)} \\ N_1^{(2)} & N_2^{(2)} & N_3^{(2)} & N_4^{(2)} \end{bmatrix} \cdot \begin{bmatrix} w_1 \\ \phi_1 \\ w_2 \\ \phi_2 \end{bmatrix}. \quad (3)$$

Curvature along the beam element is then obtained from

$$k(x) = \left[ \frac{dN_1^{(2)}}{dx} \quad \frac{dN_2^{(2)}}{dx} \quad \frac{dN_3^{(2)}}{dx} \quad \frac{dN_4^{(2)}}{dx} \right] \cdot \begin{bmatrix} w_1 \\ \phi_1 \\ w_2 \\ \phi_2 \end{bmatrix}. \quad (4)$$

To simulate the movement of the rail through the straightening machine, Eulerian description is adopted. The material moves through the beam elements, which have fixed positions in space. Development of the plastic deformation linked with the history of stress distribution over the rail cross section is detected over a mesh of discrete horizontal stripes as shown in Fig. 2. The history of each stripe is always tracked from the first node on the left end of the rail until the last node on the right end. Within one element, movement of material from node  $I$  to  $J$  of the element is linked with the curvature change

$$\Delta k = k_J - k_I \quad (5)$$

And the strain increment of each horizontal stripe is

$$\Delta \varepsilon = -\Delta k \cdot z. \quad (6)$$

Stress in each stripe, corresponding to nonlinear material behavior is evaluated, starting from the testing stress

$$\sigma_J = \sigma_I + E \cdot \Delta \varepsilon. \quad (7)$$

Subsequent correction of the testing stress  $\sigma_J$  according to plastic behavior is realized using algorithm published elsewhere [10]. This strategy results in stress, elastic and plastic strain distribution over any cross section along the rail length. For the first node, the initial stress distribution connected with the initial curvature of the rail is taken into account. Similarly, the state in the last node of last element for converged solution then corresponds to residual stress and curvature of the rail leaving the straightening machine.

Obtained distribution of stress results in correction of bending moment according to

$$M = \iint \sigma(z) \cdot z \, dS, \quad (8)$$

From which the matrix of residual loads  $\mathbf{R}_i$  for the next iteration is evaluated. In a similar way, the stiffness matrix of elements which are under active plastic deformation is modified according to [10] and a new tangential stiffness matrix  $\mathbf{K}_T$  is prepared for the next iteration. Finally, the convergence criteria are checked and the procedure is either stopped or returned back to Eq. 1 with iteration number increased by one.

## Testing Examples and Discussion

The algorithm presented above was programmed in MATLAB and verified by full time-consuming FE analysis realized by ANSYS. It can be illustrated by the straightening examples of UIC60 rail with input parameters according to Tab. 1. During straightening, the rail is moved through the leveling machine with subsequent intermeshing of adjustable rollers: 8, 6, 4 and 1 mm. The material model is supposed to behave as ideally plastic without hardening.

Table 1: Input parameters of straightening examples

Parameters	Value
Number of rollers	9
Distance between rollers (mm)	900
Yield stress (MPa)	525
Young's modulus (MPa)	210 000
Initial curvature ( $m^{-1}$ )	1/63

In Fig. 3 we show the deflection, slope, curvature and bending moment along the length of the leveled bar. The diagram of curvature shows typical nonlinear stages in plastic bending sections in comparison to linear bending moment diagram.

Loading of straightening rollers A-I (Fig. 1) is -90.4 kN, 437.4 kN, -848.3 kN, 994.1 kN, -936.0 kN, 738.1kN, -458.2 kN, 226.5 kN and -63.3kN. The input radius of curvature of 63 m is straightened to the final output value of 575 m.

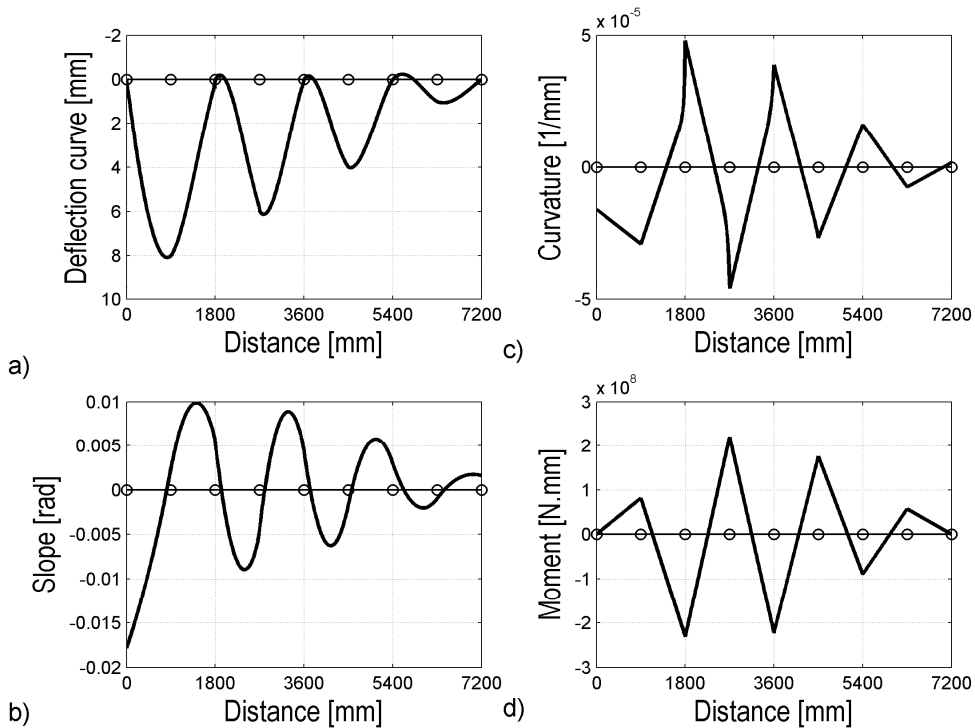

Fig. 3: Results of the testing example: a) deflection, b) slope, c) curvature and d) bending moment.

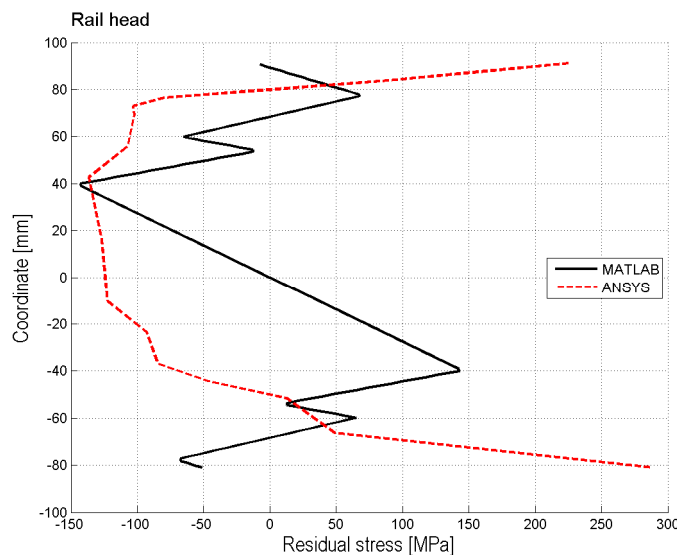

Fig. 4: Residual stress after straightening.

The final longitudinal residual stress shows a zig-zag pattern (Fig. 4). This result disagrees with the experimental and computational studies [3,4] on 3D models, where C-shaped residual stress pattern was observed. This distribution was also obtained from our detailed 2D FEM analysis (Fig. 4). Different distribution of residual stress behavior is due to the fact that our program does not take into account local contact stress between bar and roller.

## Summary

User friendly and fast program for direct solution of leveling process of long products was developed, programmed in MATLAB and tested on the illustrative example of UIC60 rail straightening. The algorithm is based on the Eulerian description of material flow through the straightening machine. This results in a very efficient code with testing example running time 3-4 minutes, compared to several hours running time of the same case solved as a 2D model in ANSYS. Main difference between the two models is in the residual stress distribution near the top and bottom surface of the rail, caused by actual absence of contact modeling in the MATLAB program. This drawback is just being eliminated and it is believed it will not substantially influence the global efficiency of our model. Efficient performance is what makes the Eulerian code an ideal tool for optimization of the straightening process, which could be applied to other processes like plate leveling, tensile leveling of thin sheets or cross roll straightening [11] of bars and tubes.

## Acknowledgement

This work is an output of research and scientific activities of NETME Centre, regional R&D centre built with the financial support from the Operational Programme Research and Development for Innovations within the project NETME Centre (New Technologies for Mechanical Engineering), Reg. No.CZ.1.05/2.1.00/01.0002 and, in the follow-up sustainability stage, supported through NETME CENTRE PLUS (LO1202) by financial means from the Ministry of Education, Youth and Sports under the „National Sustainability Programme I“.

## References

- [1] H. Tokunaga, On the Roller Straightener, *Bul. JSME* 15 (1961) 605-611.
- [2] N.K.DasTalukder, A.N. Singh, Mechanics of bar straightening, *J.Eng.Industry, Trans.ASME* 113 (1991), 224-227.
- [3] B. C. Biempica, J.J. del Coz Díaz, P.J. García Nieto, I. Peñuelas Sánchez, Nonlinear analysis of residual stresses in a rail manufacturing process by FEM, *Appl. Math. Model.* 33 (2009) 34-53.
- [4] G.Schleinzer, F. D. Fischer, Residual Stresses in New Rails, *Mat.Sci.Eng. A* 288(2) (2000), 280 – 283.
- [5] G. Schleinzer, F.D. Fischer, Residual Stress Formation during the Roller Straightening of Railway Rails, *Int.J.Mech.Sci.* 43(10) (2001) 2281–2295.
- [6] H.Song, P.L.Wang, L.H.Fu, M.Chen, Z.Q.Wang, Study on the Optimization Straightening Regulation of Heavy Rail Compound Roll Straightening, *Adv.Mat. Res.* 102-104 (2010) 227-231.
- [7] R.Kaiser, T.Hatzenbichler, B. Buchmayr, T. Antretter, Simulation of the Roller Straightening Process with Respect to Residual Stresses and the Curvature Trend, *Mat.Sci.Forum* 768-769 (2013)456-463.
- [8] M. Nastran, K. Kuzman, Stabilisation of mechanical properties of the wire by roller straightening, *J. Mat. Proc. Tech.* 125-126 (2002) 711-719.
- [9] J. N. Reddy, On locking-free shear deformable beam finite elements, *Comput. Method Appl. M.*, 149 (1997) 113–132.
- [10] D.R.J. Owen, E.Hinton, *Finite Elements in Plasticity*, Pineridge Press, Swansea, 1980.
- [11] J. Petruska, T.Navrat, Computational simulation of cross roll straightening. Proc. of 3rd South-East European Conference on Computational Mechanics, (2013) 548-555.