

# A Voltage Support Schemes of Asymmetrically controlled Three-Phase Inverter-Based Generating Units

J. Dvořáček<sup>1</sup>, J. Drápela<sup>1</sup>

<sup>1</sup>Dept. of Electrical Power Engineering, FEEC, Brno University of Technology, Czech Republic

E-mail: [dvoracekj@vut.cz](mailto:dvoracekj@vut.cz), [drapela@vut.cz](mailto:drapela@vut.cz)

**Abstract**—Paper provides insight into possibility of asymmetrical three-phase inverter high-level control as additional grid support in low voltage networks. The asymmetrical control may assist with lowering asymmetry in areas with large single-phase load/generation penetration. Proposed and implemented control schemes are tested with laboratory equipment utilizing artificial network. Results are evaluated based on their effect on voltage asymmetry reduction and neutral conductor current magnitude.

**Keywords**— three-phase inverter-interfaced generating unit, photovoltaic source, battery energy storage system, voltage asymmetry, grid support functions, asymmetrical control

## 1. INTRODUCTION

Ongoing transition from a centralized electric power generating facilities to more decentralized energy resources (DER) leads to an increased number of a power generating units (PGU) installed into low-voltage (LV) network; increasingly supplemented by battery energy storage systems (BESS) [1]. It turns out that PGUs and BESSs in the LV distribution system (DS) have a significant local influence on the voltage magnitude and affect (even in combination with asymmetrical loads) its asymmetry [2]. However, it may not be only the deterioration of voltage quality indices in DS [3]. The DERs may also contribute intentionally to their improvement. Particularly, three-phase inverter-interfaced DERs with ability of asymmetrical current injection are of potential to compensate voltage asymmetry, typically linked to LV DS. Therefore, asymmetrical current injection higher-level control may assist voltage symmetrization in LV DS with large single-phase demand or generation assets. The paper aims to several proposed asymmetrical current/power distribution control schemes and their experimental verification. In order to assess the control strategies performance, the algorithms are implemented with use of an instrumentation platform controlling a three-phase hybrid inverter.

## 2. INTEGRATION OF LV INVERTERS-BASED GENERATING UNITS

There are multiple options for inverter-interfaced DER topology and its integration into LV DS. Relevant examples are documented in figure 1. Despite equipment at the inverter DC side terminals (photovoltaic (PV) strings or BESS), the inverter's topology is important in view of the study. In general, single-phase or three-phase inverters may be used, whereas 3-phase asymmetrical controlled injection to the DS is achievable by three-phase unit or three single-phase units only.

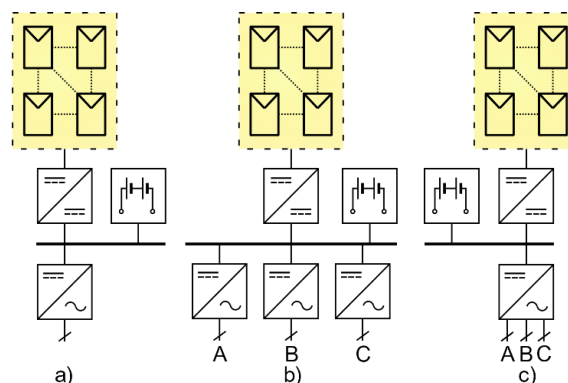

**Figure 1:** Basic topologies of inverter-interfaced generating units' connection to three-phase LV network; a) single-phase inverter, b) three single-phase inverters, c) single three-phase inverter

Current or power disposable (assumed as constant) at DC link (DC/AC converters are typically operated as current source) is to be provided into AC three-phase system via following control schemes:

- Symmetrical – current is distributed symmetrically into all phases regardless of system voltage asymmetry; as this is a standard control of symmetrical 3-phase inverters.
- Asymmetrical - phase currents are controlled by chosen strategy while sum of distributed currents remains constant. Obviously, this is not available for single-phase connection (figure 1a), while it is to be natural in the case of three single-phase inverters in figure 1b). Finally, asymmetrical control of the 3-phase inverter (figure 1c) is available for specialized 3-phase PV inverters or BESS converters only.

As stated in (1) for fundamental frequency, voltage drop across a AC supply system impedance is affected by active and reactive current. Since (1) applies for L-N voltages as well as L-L, asymmetrical distribution of current will affect voltage asymmetry, and inversely, can contribute intentionally to its symmetrization.

$$\Delta U \approx r I_a + X I_r \quad (1)$$

where  $\Delta U$  denotes voltage drop magnitude,  $r$  resistance and  $X$  reactance at supply/delivery point,  $I_a$  means active and  $I_r$  reactive current, respectively, and all at fundamental system frequency.

### A. Considered Asymmetrical Power Control Approaches

It is desirable to restrict total active power limiting to minimum due to the unwanted active power generation disturbances. Important condition to asymmetrical power control is therefore to pass through all available power from DC interlink ( $P_D$  or  $I_D$ ) when possible and up to the inverter AC rated current  $I_R$ . Current oriented (CO) and power oriented (PO) strategies presented in table 1 are considered for AC side phase distribution. The naming is chosen with respect to their calculation and their desirable effect is to balance voltage by means of phase-by-phase (*ph*) active current/power distribution. Schemes are chosen for power generation, where the phase current/power is calculated directly proportional according to chosen scheme to supply more power to phase with lower voltage. For consumption (a case of BESS), phase current/power would have to be distributed with inverse proportions to achieve lower demand on phase with lower voltage.

**Table 1:** Considered control strategies

Current oriented		Power oriented	
Notation	Voltage exponent, $n$ (-)	Notation	Voltage exponent, $n$ (-)
A) ( <i>ph</i> )	0	D) ( <i>ph</i> ) $U(ph)$	-1
B) ( <i>ph</i> ) $U(ph)$	1	E) ( <i>ph</i> )	0
C) ( <i>ph</i> ) ( <i>ph</i> )	2	F) ( <i>ph</i> ) $U(ph)$	1

Respective phase current for CO strategies is calculated acc. to (2). With PO strategies, respective phase active power is calculated acc. to (3). Calculation differences are expressed with voltage exponent as presented in table 1. Strategies on same row should be (acc. to their respective calculation) equivalent.

$$I_{ph} = \frac{I_D}{\sum U_{ph}^n} U_{ph}^n \quad (2)$$

where  $I_A, I_B, I_C$  are currents flowing through respective phases and  $I_D$  is disposable current,  $U_A, U_B, U_C$  are measured L-N voltages. The  $I_D$  and  $I_R$  denotes disposable and rated current, respectively. The  $n$  is an exponent listen in table 1.

$$P_{ph} = \frac{P_D}{\sum U_{ph}^n} U_{ph}^n \quad (3)$$

where  $P_A, P_B, P_C$  denote power inputs into respective. The  $P_D$  means disposable power.

## 3. EXPERIMENTAL VERIFICATION

Experimental verification was conducted using setup depicted in figure 2. Due to unavailability of commercial product with direct reference value (power, voltage, frequency etc.) input, custom system

was composed using three single-phase digitally controlled hybrid converters Studer XTM-4000-48 and a virtual instrumentation based external current/power control loop [4]. The outer current/power setup loop consists of National instruments (NI) cDAQ measuring platform and a PQ control SW developed in LabVIEW and providing requested AC side current/power setting for the converters via RS232 communication. The converters terminal voltages and currents are measured using NI 9225 module and NI 9239 module in combination with Chauvin Arnoux C173 current transducers, respectively. The PQ control SW implements active current or power redistribution algorithms as defined in section 2.

Test setup consists of grid-connected 4-quadrant artificial AC grid simulator providing controllable 4-wire LV network [5]. The converters (Studer XTM-4000-48) are connected to each phase through identical impedance. Converters are provided by common DC link powered by two Li-Ion battery packs connected in parallel supported by a DC power supply. Used XTM converters accept only current magnitude and phase input from control loop. This is an important attribute of used setup as power in PO strategies is inputted as current considering actual voltage level. Moreover, current setup with resolution of 0.2 A is accepted by the XTM converters only. Measurement for the performance evaluation purpose at AC terminals of the PGU is performed by a power analyzer and data logger HIOKI PW3390. The table 2 presents impedances used in test setup according to figure 2. Impedances  $Z_L$  and  $Z_N$  were chosen according to reference impedance [6] and expected loading of the network.

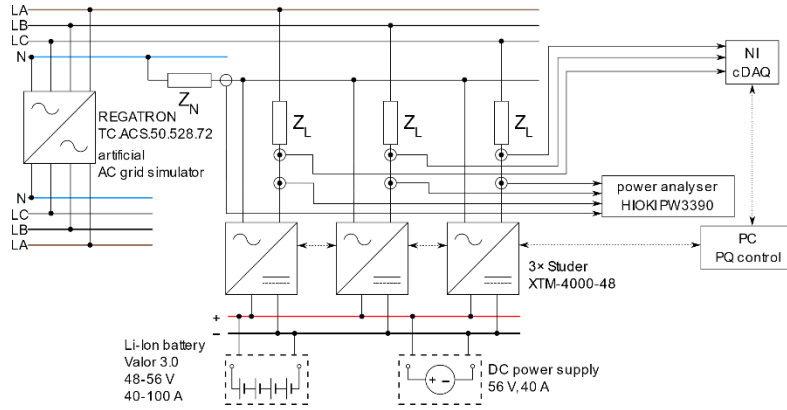

Figure 2: Test setup diagram

Table 2: Test system impedances

Test setup		Referenced in [6]	
Label	Value ( $\Omega$ )	Label	Value ( $\Omega$ )
$Z_L$	$(0.28 + j0.18)$	$Z_{L,ref}$	$(0.24 + j0.15)$
$Z_N$	$(0.20 + j0.11)$	$Z_{N,ref}$	$(0.16 + j0.10)$

Table 3: Considered nominal values

Grid simulator		Each inverter	
Parameter	Value	Parameter	Value
$U_n$ (L-N)	220 V	$P_{D,ph}$	1500 W
$f_n$	50 Hz		

### B. Testing Scenario

The grid simulator was set up to output voltage profile as show in figure 3 with nonstandard nominal value according to table 3. Lower voltage was chosen to prevent automatic power curtailment of inverter due to positive error of its internal voltage measurement. Nominal by-phase power according to table 3 was chosen due to maximal power safely provided by used DC sources.

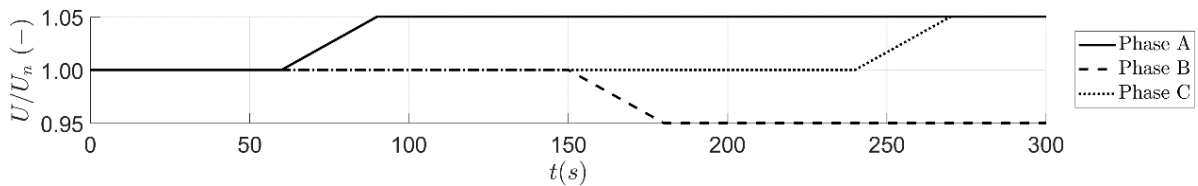

Figure 3: Test voltage profile

#### 4. EVALUATION OF THE ASYMMETRICAL POWER CONTROL APPROACHES

Suitability of control strategy is evaluated using coefficient of voltage asymmetry calculated at fundamental frequency with (4) [7] and by means of fundamental frequency current at neutral conductor. All visualized data were also smoothed using moving average function to eliminate ripple.

$$k_{v2} = \frac{U_{(ph)} - U_{(ph)}}{U_{(ph)} + U_{(ph)}} \quad (4)$$

where  $k_{v2}$  denotes coefficient of voltage asymmetry,  $U_{(ph)}$  means positive sequence voltage at fundamental frequency, and  $U_{(ph)}$  is negative sequence voltage at fundamental frequency.

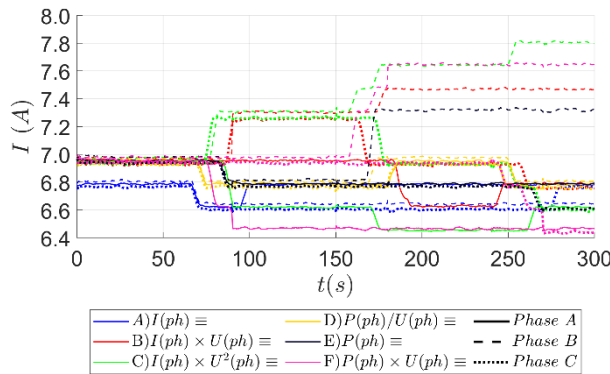

Figure 4: Inverter AC current (fund. freq.)

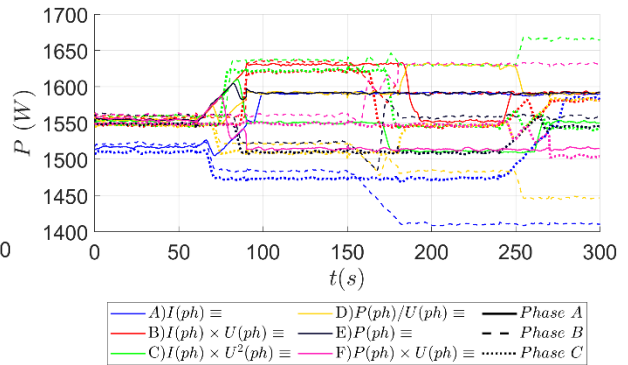

Figure 5: Inverter active power output

Results are affected by stepped current input. It is not set exactly but in steps by 0.2 A only as seen in figure 4. Therefore, power output is also stepped as referenced in figure 5. This limitation is particularly evident with strategies A) and D) as phase currents are not kept constant and with B) and E) as the active power output differs between phases.

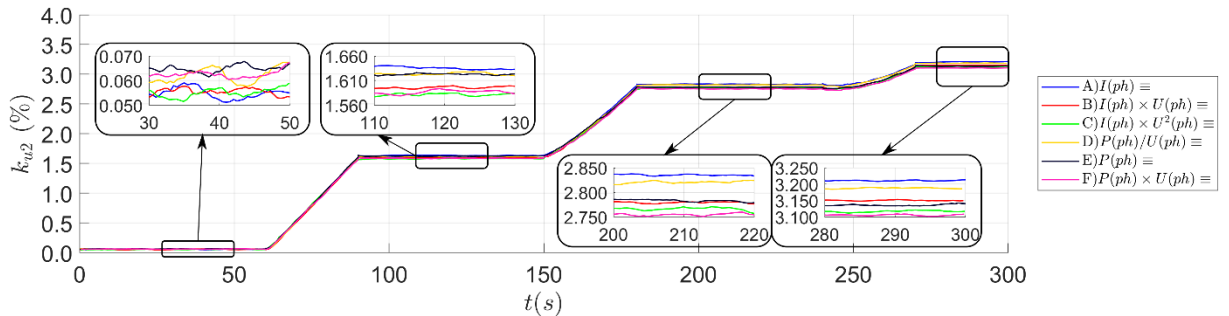

Figure 6: Coefficient of voltage asymmetry (fund. freq.)

Even though strategies A) and D); B) and E); C) and F) were assumed to have similar effect, actual values presented in figure 4 and figure 5 indicate differences between respective CO and PO. This may be caused by aforementioned limitation. Similarly, for strategies A) and D), respective phase currents deviate much less throughout test setup than with using other strategies.

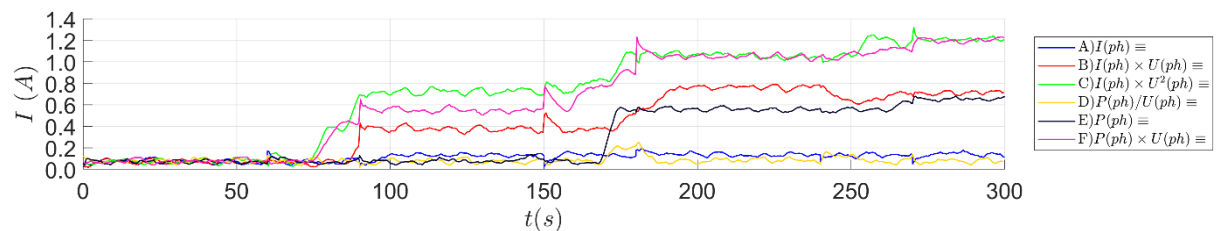

Figure 7: Neutral conductor current (fund. freq.)

Finally, using B) and E), active power output is less deviated (than with other strategies) across phases as seen in figure 5. Using C) and F), current in phases with lower voltage is set higher. A difference of

CO and PO is likely caused by difference in referencing voltage magnitude. PO respects actual voltage level, while CO is referenced to nominal/rated voltage in the tested control loop. Effect on reducing asymmetry is not significant in this power level as seen in figure 6. However, the response is present and consistent throughout testing. Lowest asymmetry was achieved utilizing C)/ F) – utilizing phase voltage in effect for current/power control additionally to other PO and CO focused on constant current/power. Also, the B)/ E) (const.  $P$ ) mitigate asymmetry better than A)/F) (const.  $I$ ).

Downside of asymmetrical control strategy is its impact on current flowing through neutral conductor, as shown in figure 4. Strategies able to remedy asymmetry more throughout test at POC show significantly higher current through neutral conductor than other strategies. Difference between PO and CO is again due to measurement and reference differences.

## 5. CONCLUSION

The paper has been aimed on several higher-level control strategies for asymmetrical current/power control of grid connected three-phase DC/AC converters. The asymmetrical injection based on line-neutral voltage magnitude is intentionally employed in favor of the supply voltage symmetrization, therefore, providing the supply network goal-directed support. Performance of the strategies in generating mode were assessed using laboratory testing equipment. However, similar control may be addressed for a BESS charging mode. Benefit from the asymmetrical control strategies to voltage symmetrization contribution, in comparison to symmetrical injection, was proven. The strategies were proposed rather less invasive, therefore, the effect of controlled asymmetrical by-phase distribution of the single PGU was relatively small. If coexistence of contribution from multiple units across a LV DS will occur the stronger effect may be expected. On other hand, asymmetrical injection exhibits neutral conductor current whose magnitude rises with level of the set injection asymmetry obviously. The resulting neutral wire current may cause additional losses, which might be undesirable. More thorough testing is required to establish solid ground for selecting proper asymmetrical control strategy if shown sufficient grid supporting potential.

## ACKNOWLEDGMENT

This research work has been carried out in the Centre for Research and Utilization of Renewable Energy (CVVOZE). Authors gratefully acknowledge financial support from the Ministry of Education, Youth and Sports of the Czech Republic under BUT specific research program (project No. FEKT-S-20-6449).

## REFERENCES

- [1] Michael I. Henderson, Damir Novosel, and Mariesa L. Crow, “Electric Power Grid Modernization Trends, Challenges, and Opportunities,” IEEE, 2017
- [2] M. Vrana *et al.*, “Battery Storage and Charging Systems Power Control Supporting Voltage in Charging Mode,” *2020 19th International Conference on Harmonics and Quality of Power (ICHQP)*, 2020, pp. 1-6, doi: 10.1109/ICHQP46026.2020.9177889.
- [3] *Voltage characteristics of electricity supplied by public distribution networks*, EN 50160:2010, 2010.
- [4] J. Drapela, J., et al., “Power Generating Modules Field Testing Concepts for Verification of Compliance with Operational Requirements,” *2020 21st International Scientific Conference on Electric Power Engineering (EPE)*, 2020, pp. 1-6, doi: 10.1109/EPE51172.2020.9269230.
- [5] “Grid Simulators & Systems.” Regatron. <https://www.regatron.com/product/products-by-application/grid-simulators#general-overview> (accessed 2022-03-13).
- [6] *Electromagnetic compatibility (EMC) – Part 3-3: Limits – Limitation of voltage changes, voltage fluctuations and flicker in public low-voltage supply systems, for equipment with rated current  $\leq 16$  A per phase and not subject to conditional connection*, EN 61000-3-3, 2013.
- [7] *Electromagnetic compatibility (EMC) – Part 4-27: Testing and measurement techniques – Unbalance, immunity test*, EN 61000-4-27, 2000.