

System for measurement and control of pressure in vacuum apparatus

Sedlar J.

Faculty of Electrical Engineering and Communication,
DCI, Brno University of Technology
Technická 12, 616 00 Brno, Czechia
xsedla1x@vut.cz

Jurik K.

Faculty of Electrical Engineering and Communication,
DTEEE, Brno University of Technology
Technická 12, 616 00 Brno, Czechia
187537@vut.cz

Abstract—This paper summarizes the development and implementation of a device designed for controlling and operating a vacuum gas chamber. Multiple vacuum gauges, a gas pump and a valve can be connected to the device. Communication between the user and the system occurs via a large touch screen with an organized interface. The article describes the current state of development and outlines future improvement possibilities and potential applications.

Index Terms—Vacuum control, pressure measurement, vacuum instrumentation

to the system, as opposed to relying on a commercial solution. Furthermore, the system's ability to offer functional control for different vacuum systems at a reduced cost could aid in offsetting the cost of research.

The heart of this system, which is the main focus of this article, is a printed circuit board (PCB) extension to an Arduino board that manages the communication with devices used for vacuum measurement, control and human-machine interface (HMI), further referred to as VSC (vacuum system controller).

II. APPLICATIONS

The device described in this article enables easy integration of many broadly used vacuum operations equipment. The full potential of the system can be utilized for simultaneous gas pressure measurements and regulation but it is also possible to use just one of these functions if the application requires it. Although similar devices have been available on the market for many years, they might be difficult to obtain for small research teams or individuals due to the resources required for their acquisition. The purpose of the device described in this article is to provide a functional alternative with comparable quality to a professional-level system but with much greater accessibility.

III. SYSTEM DESCRIPTION

The system is designed to be a simple, ready-to-use computer, with internal structure organized as shown in Fig. 2. This computer serves not only for communication and control of vacuum devices but also as their power source. All peripherals are connected via standardized ports typically used in similar applications. Such peripherals are up to two vacuum gauges used for gas pressure measurement, one vacuum pump removing gas particles from the chamber and one vacuum valve serving as a regulating device for controlled gas intakes.

The system's flexibility is increased by the fact that it can be used with various vacuum operation devices designed by *Pfeiffer Vacuum*. Users' requests and demands are inputted through a large Nextion touch screen panel embedded into the device body. The same screen is used to display various information regarding the current gas pressure and the general state of the vacuum system. To log this data, users can insert an SD card, which is subsequently used to store all important information for later evaluation of results.

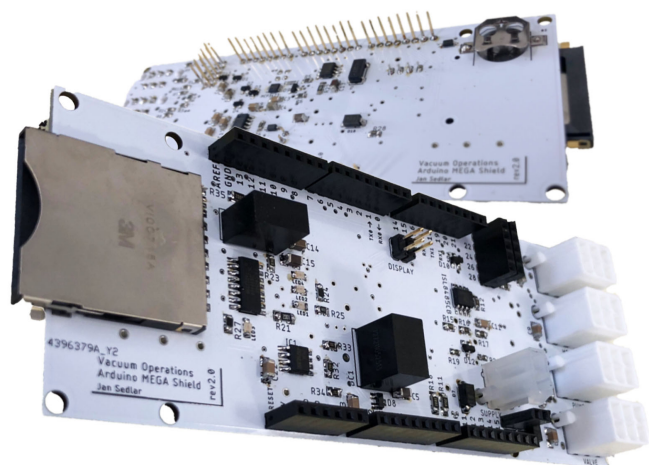

Fig. 1. Vacuum system controller custom PCB extension unit

I. INTRODUCTION

This article is aimed at describing the function of a system for controlling and operating a vacuum chamber. The main goal of such system is to monitor gas pressure in the chamber and to set the pressure according to user's requests.

The initial motivation for design of such a device was to enable laboratory research in low-pressure environments. Custom design of the pressure control unit potentially enables more possibilities and could provide the researches with greater flexibility by incorporating their requirements directly

The preparation of this paper was supported by the project No. FCH/FEKT-J-23-8282 of the BUT internal grant office.

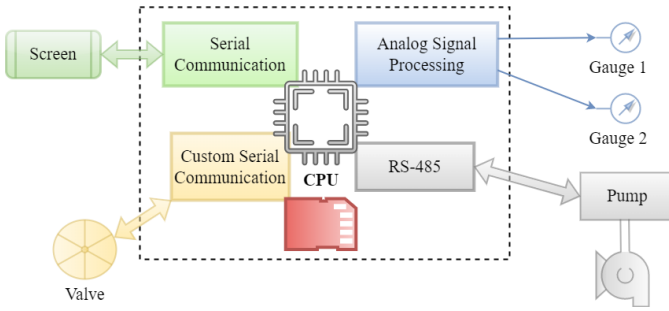

Fig. 2. System design diagram

As previously suggested, a custom PCB was designed and engineered to incorporate all essential circuitry required to implement the aforementioned features. The power-intensive peripherals were situated on the port side of the PCB, whereas the signal paths and processing components were positioned on other sections of the board, as demonstrated in Figure 3. A fully operational and assembled PCB extension unit can be observed in Figure 4.

IV. COMMUNICATIONS

Different vacuum operations devices use varying communication protocols to send or receive data from the control unit. This had to be taken into account during the design of the VSC. While the pump and its controller are commanded via the standardized RS-485 interface [1] [2] [3], a more specific solution had to be implemented for the vacuum valve. The digitally controlled valve uses a half-duplex serial bus with atypical voltage levels defined for individual logical values and slow transmission speed (300 baud rate) [4]. The implemented solution is derived from the RS-232 communication protocol with its voltage level adjusted for this specific application. Both devices use a different set of instructions for their control.

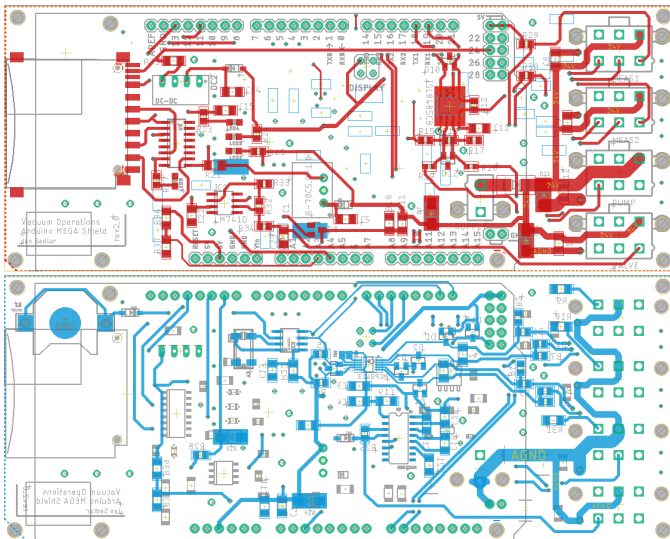

Fig. 3. 2-layer custom PCB extension design

The pump is commanded by *Pfeiffer Vacuum Protocol* messages [5], which are broadly used when more complex Pfeiffer vacuum products are concerned. The valve, on the other hand, implements a much simpler instruction list consisting of just a few commands enabling its basic control, settings and its current state determination [4]. Furthermore, to increase the flexibility of the VSC, a digital to analog conversion with a voltage step-up module was implemented for enabling the usage of a valve control via optional analog voltage line.

For the gas pressure acquisition, it was required to implement an analog to digital conversion, since many of the Pfeiffer Vacuum gauges represent the measured pressure as a voltage value [6] [7] [8]. This value is processed in an ADC (analog to digital converter) with high resolution of 18 bits providing no significant loss of precision during the conversion. ADC processes the data and sends the final output to the VSC via an I²C interface. The same serial interface is used for acquiring or storing the data to the optionally inserted SD card.

For the internal communication with the Nextion HMI display a simple Arduino UART bus is used. The touch screen is also commanded by a standardized set of instructions and the device itself is programmed by a unique language.

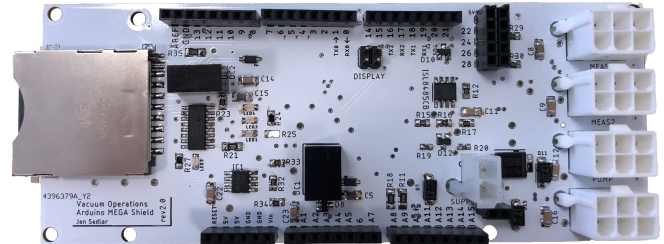

Fig. 4. Custom PCB extension unit top view

V. POWER SUPPLY

As previously mentioned, the VSC not only controls all connected peripherals but also acts as their main power source. A powerful source of up to 200 W had to be used, mainly because of the pump's large power consumption. The main power input circuitry of the VSC therefore accommodates multiple protections such as a basic protection against polarity reversal or against sudden peaks of input voltage. Additional pieces of protection hardware like Zener diodes, basic Schottky rectifiers or specialized serial communication lines protection diodes are located at every input leading into or output heading out of the VSC. The main power supply delivers a stable 24 V used to power all external peripherals, such as the pump and valve. Additionally, the internal circuitry operates at lower voltage levels, requiring two step-down converter circuits on the PCB, providing 5 V and 3.3 V, respectively.

VI. CENTRAL PROCESSING UNIT

In the current iteration of the project a widely used Arduino-based board is utilized as the main unit for processing. Specifically, an Arduino Mega with the ATmega 2560 chip is used which delivers enough computational power for servicing all incoming or outgoing requests [9]. The board was chosen for this application due to its multiple serial communication line modules and its easy expandability with additional circuitry, such as the custom-designed shield module for this particular application.

VII. HUMAN-MACHINE INTERFACE

The display's interface is designed with simplicity and ease-of-use in mind. The main screen (Fig. 5) displays all critical information related to the system's operation, while additional menus for data acquisition and storage, peripheral settings, and user presets can be accessed through multiple buttons located on the side of the main screen.

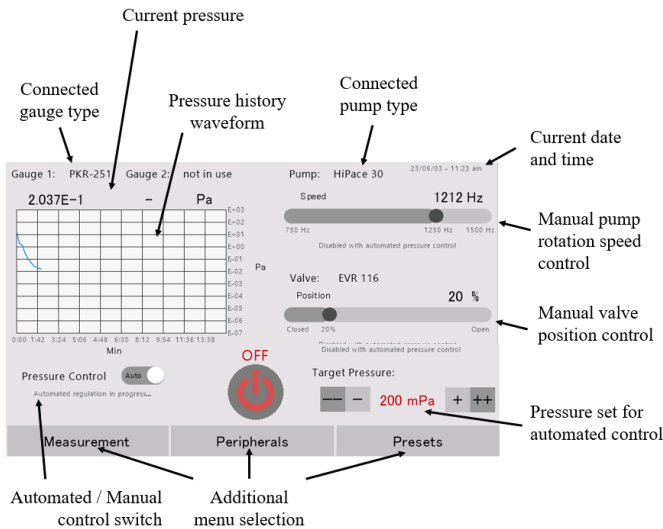

Fig. 5. Human-Machine Interface main screen

VIII. SOFTWARE

The program running on the Arduino CPU must handle variety of tasks simultaneously, including the regulation of the gas pressure and communication with connected peripherals, accurate data acquisition or capturing and executing user's commands. While the current CPU is sufficient for these tasks, an upgrade to a more powerful or even multithreaded CPU shall be considered in the future when more demanding tasks are implemented.

With regards to the overall slow dynamic of the gas system, it is not necessary to have the parts of the algorithm servicing measurements and pump or valve control running in a loop at particularly high speeds. Data from the peripherals are acquired once every three seconds and the outgoing commands are sent at the same rate. On the other hand, user inputs must be handled in near real time, so the loop responsible for capturing these inputs repeats itself as frequently as possible

to lower the response time of the touch screen to a bare minimum. The design of the Nextion displays represents a significant advantage—graphic tasks, such as rendering a new page or animations, are handled by the display's CPU and only important changes of the screen's state are sent over the serial line to be processed by the VSC.

At the time of writing this article a prototype of automated gas pressure regulation is being implemented, which will replace the currently used manual control of pump rotation speed or valve position. The purpose of such regulation is to achieve the gas pressure given by the user in the shortest time possible. In the upcoming iterations, the aim is to expand this feature by allowing the user to set the pressure progression in time. This would enable the creation of arbitrary gas pressure gradients, limited only by the vacuum hardware used in the application.

IX. TESTING AND VALIDATION

The pressure values obtained as a voltage output from the VSC's 18-bit internal ADC were compared to those acquired with a laboratory-grade voltage measuring equipment of high precision. The error caused by the VSC is only given by the ADC's precision, as the gauge's accuracy cannot be influenced directly. The calculated error was found to be insignificant in comparison to the inherent error attributed to the gauges themselves, as anticipated.

The validation of the peripherals' correct functioning was done by evaluating the effect of the peripheral's state change (e.g. rotation speed) on the measured pressure values. Additionally, the confirmation of command acceptance by the peripherals was determined through the interpretation of acknowledgment response messages.

X. FUTURE IMPROVEMENTS

Apart from already mentioned automated pressure control and its gradient that is currently being worked on, there are several other tasks that need to be addressed. Firstly, the VSC needs to be able to automatically identify the connected chamber system. This is important because the automated control requires precise knowledge of the gas chamber properties and must be readjusted after any changes to the system's topology. Secondly, a basic interface for remote access needs to be implemented to enhance the user experience and provide the ability to control ongoing experiments remotely. The vision here is to establish a basic internet server which is connected to the system and therefore enables the user to command or oversee currently ongoing system operation and not be directly present by the vacuum chamber itself. And finally, it is desirable to implement more connection possibilities for the usage of different vacuum modules which do not utilize the means of communication as described in IV. This will further broaden the device's flexibility and allow it to be used with a broader range of vacuum control systems without requiring a redesign of the VSC's internals.

XI. CONCLUSION

Although the current iteration may require several improvements to meet today's state-of-the-art devices, the first steps for a functional alternative to professional vacuum operations devices are already laid. The device is capable of communicating with a wide range of modules that are commonly used in vacuum chamber control, and can execute commands in accordance with the user's requests as input through the touch screen interface.

REFERENCES

- [1] "Hipace 10 with tc 110 product datasheet." <https://static.pfeiffer-vacuum.com/productPdfs/PMP03960.en.pdf>. [online], [seen 10. 03. 2023].
- [2] "Hipace 80 with tc 110 product datasheet." <https://static.pfeiffer-vacuum.com/productPdfs/PMP03940.en.pdf>. [online], [seen 10. 03. 2023].
- [3] "Hipace 800 with tc 400 product datasheet." <https://static.pfeiffer-vacuum.com/productPdfs/PMP04300.en.pdf>. [online], [seen 10. 03. 2023].
- [4] "Evr 116 motorized valve product datasheet." <https://static.pfeiffer-vacuum.com/productPdfs/PFI39931A.en.pdf>. [online], [seen 10. 03. 2023].
- [5] "Pfeiffer vacuum-protokoll." Schnittstelle RS-232, RS-485.
- [6] "Cold cathode vacuum gauge pkr251 product datasheet." <https://static.pfeiffer-vacuum.com/productPdfs/PTR26000.en.pdf>. [online], [seen 10. 03. 2023].
- [7] "Cold cathode vacuum gauge ptr91 product datasheet." <https://static.pfeiffer-vacuum.com/productPdfs/PTT03148310.en.pdf>. [online], [seen 10. 03. 2023].
- [8] "Pirani vacuum gauge tpr 270 product datasheet." <https://static.pfeiffer-vacuum.com/productPdfs/PTR26770.en.pdf>. [online], [seen 10. 03. 2023].
- [9] ARDUINO, "Arduino.cc." <https://arduino.cc>. [online], [seen 10. 03. 2023].