

Horticulture IoT module

M. Šimek, J. Arm

FEEC, Brno University of Technology, Czech Republic

E-mail: xsimek29@vut.cz, arm@vut.cz

Abstract— This paper deals with the measurement of soil parameters and growing conditions. The processes required to continuously monitor and ensure ideal growing conditions are quite time consuming. Therefore, the aim of this work will be to design and implement a module that eliminates the need for human interaction in monitoring important parameters and can be used as a part of a complex autonomous cultivation system. The main requirements of the proposed module include energy self-sufficiency and wireless communication with the master device.

Keywords—soil bulk EC, volumetric water content, ESP-32D, LoRa

1. INTRODUCTION

Maintaining ideal growing conditions throughout the entire plant cycle is an extremely challenging process that requires constant human interaction in the absence of supporting automation.

The subject of this work is to design a module that will be able to monitor the necessary parameters of the growing process in a defined period of time. According to these measured values, processes such as fertilization, humidification, ventilation, and irrigation of the area in which the sensor is located can be controlled. The following requirements and parameters that have been determined for the proposed module: energy self-sufficiency, wireless communication with the master system, local access to measured values, measurement of soil parameters (bulk EC, VWC and temperature), measurement of ambient air parameter (temperature and relative humidity) and calibration of bulk EC and VWC sensors.

2. SOIL WATER CONTENT

Soil water content (SWC) represents the amount of water contained in a soil sample with certain properties. There are two main basis for determining SWC: gravimetric and volumetric.

Gravimetric water content (θ_g , *GWC*) is defined by mass of water (M_w) per mass of dry soil (M_s). It can be measured by weighing a soil sample (M_t), then removing the water by drying and weighing the dried soil. [1]

$$\theta_g = \frac{M_w}{M_s} = \frac{M_t - M_s}{M_s} [-] \quad (1)$$

Volumetric water content (θ_v , *VWC*) is defined as ratio of the water volume (V_w) to the total volume of soil sample (V_t). Gravimetric water content can be converted to volumetric by knowing the density of water (ρ_w) and bulk density of soil sample (ρ_b). [1]

$$\theta_v = \frac{V_w}{V_t} = \theta_g \frac{\rho_b}{\rho_w} [-] \quad (2)$$

Another important variable is water content at saturation (θ_s) which gives us information about how much water content the soil sample can hold. It can be determined according to the following formula.

$$\theta_s = 1 - \left(\frac{\rho_b}{\rho_s} \right) [-], \quad (3)$$

where ρ_s denotes density of solids (which is typically 2.65 g/cm^3 for mineral soil [2])

Volumetric water content can be determined indirectly by measuring of the following soil parameters:

- Electrical resistance – inserting the electrodes into the soil and exciting them with a current source creates a voltage drop from which the electrical conductivity or resistance of the soil can be calculated. Increasing water content resolves in decreasing resistance across measuring electrodes. However, an increase in the soil's conductivity results in a decrease in its resistivity even if the water content has not changed at all. These facts make this method unsuitable for accurate measurement of soil water content.
- Dielectric permittivity – the dielectrical constant of the soil ranges from 2–3 depending on the physical, mechanical, and chemical properties of the soil, whereas the dielectrical constant of water is about 80. The resulting permittivity of the soil sample is therefore strongly influenced by the amount of water it contains. To determine the permittivity of the soil sample, mainly FDR (Frequency Domain Reflectometry), TDR (Time Domain Reflectometry) and capacitive methods are used. [2]

3. SOIL ELECTRICAL CONDUCTIVITY

Electrical conductivity of the soil gives us an idea of the total amount of dissolved salts in a soil sample. By measuring this parameter, it is possible to prevent over-fertilization or nutrient deficiencies in the substrate and thus guarantee the correct development of the plant throughout its growing cycle.

There are many ways to describe soil EC, but the most common are following [2]:

- Bulk EC (σ_b) – electrical conductivity of the bulk soil, it's strongly influenced by SWC and total dissolved salts in soil sample. All sensors which are placed directly in a soil sample measure this parameter.
- Pore water EC (σ_w) – this parameter represents electrical conductivity of water in soil pores and gives us information about what conductivity the plant is experiencing. It can be measured by extracting pore water from the soil sample and measuring its EC.
- Saturation extract EC (σ_e) – value represented by electrical conductivity of extracted water from saturated soil sample. Indicates the amount of salts contained in the soil sample. It is measured by adding deionised water to the soil sample until it is saturated and then extracting the water and measuring its EC. Depending on the θ_v , it is 3 times to 9 times larger than σ_b .

According to the following equation, it is obvious that when the soil sample is at the saturation point, the EC of pore water and the EC of saturation extract are equal. [2]

$$\sigma_e = \sigma_w \left(\frac{\theta_s}{\theta_v} \right) [mS/cm] \quad (4)$$

4. STEM-01 MODULE

In accordance with the requirements of the introduction and for the need of continuous monitoring of volumetric water content and soil bulk EC, the STEM-01 module (abbreviation for Soil moisture, Temperature and humidity, Electrical conductivity Module) was designed.

The ESP32 microcontroller was chosen as the main controller of the module, mainly due to its sufficient computational power, support for IEEE 802.11 communication standards, and wide support for device libraries. As a part of energy self-sufficiency, the module is powered by a LiPo battery which is recharged by a charger powered by a solar cell, thus ensuring its long-term operability and eliminating module maintenance in the form of battery replacement or manual recharging. For the determination of VWC, the method of measuring the capacitance of an interdigital capacitor placed in a soil sample was chosen. Capacitance measurements can be made directly using the touch inputs of the ESP32 controller. To measure soil conductivity, a circuit consisting of an ADC with differential inputs and programmable gain amplifier, a 2xSPDT multiplexer, an h-bridge, a shunt resistor and the conductivity probe itself was designed. The principle of conductivity measurement is as follows: a positive voltage pulse is generated using the h-bridge, during which the voltage drop across the shunt resistor is first measured, then the ADC input is redirected to probe electrodes using a multiplexer and the voltage drop across it is also measured. The same procedure is repeated for the generated negative voltage pulse. The resulting voltage drop across the shunt resistor is then used to calculate the current through the probe and, thanks to the known voltage drop, its resistance can be calculated. Using the calculated probe resistance, the

electrical conductance of the probe is further determined, and the final electrical conductivity is determined using the cell constant. The SHT-40 sensor is used to measure the temperature and relative humidity of the environment and a DS18B20 temperature sensor located near the EC probe for its calibration and temperature compensation of electrical conductivity.

The STEM-01 module has two modes of operation: low-power mode and local access mode. In local access mode, it is possible to connect via WiFi to the ESP32 on which a web server is running. Through this web server you can perform the initial setup of the module, monitor the current measured values and perform calibration of EC and θ_v measurements. In low-power mode, the module wakes up cyclically from deep sleep mode, sends the measured data via LoRa technology to the gateway and go back to sleep. The gateway then sends the received data to the MQTT broker into the preset topic. Block diagram of the module is shown in the figure 1.

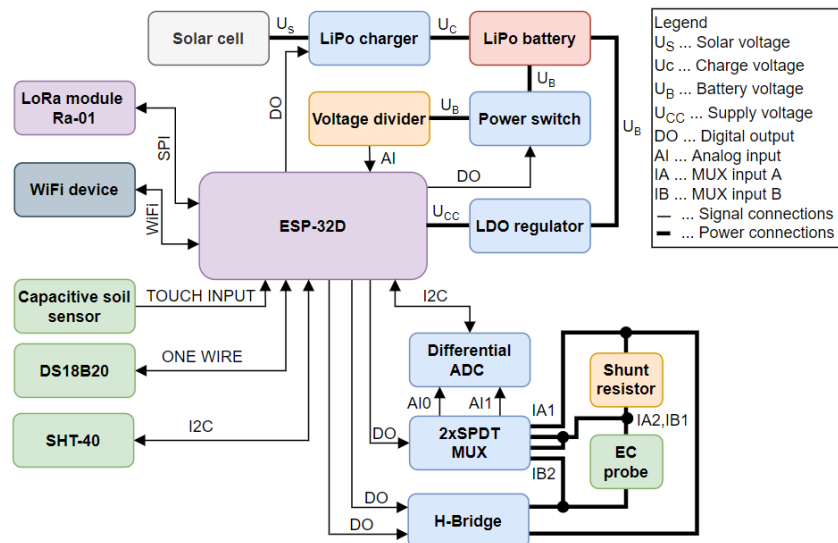

Figure 1: Block scheme of module STEM-01

A waterproof box was designed in Autodesk Fusion 360 for the individual components and the circuit board. The box consists of three main parts: the lid on which the solar panel is mounted, the body in which the PCB is placed and the stem which contains the EC probe, the DS18B20 sensor and the interdigital capacitor for water content measurement. Designed box and DPS are shown in figure 2.



Figure 2: 3D enclosure design, real enclosure, PCB

5. CALIBRATION PROCEDURES

The water content measurement can be performed in two modes. In the first mode, the sensor can be calibrated in two steps by first measuring the number of pulses of the capacitive input N_c when the sensor is placed in air (water content equals to 0 %) and then measuring N_c for the sensor placed in water (water content equals to 100%). Based on these two values, a regression line of the water content on the inverted N_c value is then calculated. The second mode measures directly the volumetric water content. For this mode to work correctly, it needs to be calibrated as follows: a certain volume of dry soil sample (in our case 300 ml) is placed in the container, then the N_c corresponding to a $\theta_v = 0$ is measured, then 30 ml of water is added to the container (10% increase of the θ_v), the soil is mixed properly and the number of

pulses of N_c is measured again. Adding water, mixing and measuring N_c is repeated until the soil sample starts to seep water. From the logged values of N_c and their corresponding θ_v , linear regression line is calculated. However, the obtained regression is valid only for soils of the same or very similar type. Therefore, if the calibration is performed on peat and the sensor is subsequently moved to a location with clay soil, this calibration process must be performed again. A sample calibration process was performed in the θ_v range of 0 - 0.5 for a peat-like sample with $\rho_b = 0.88 \text{ g/cm}^3$. This resulted in the following equation illustrated in the following graph (figure 3).

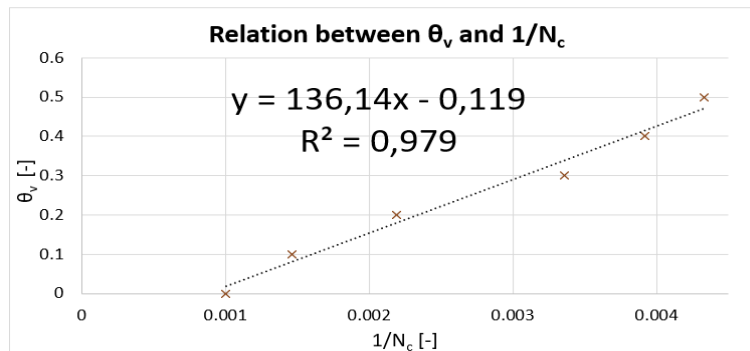

Figure 3: Relation between θ_v and $1/N_c$

As already mentioned, the EC sensor measures σ_b . Its calibration therefore consists mainly of placing it in a reference solution of known electrical conductivity σ_c , where the probe conductance G_p is first measured, and the cell constant K is determined from the known temperature T_0 of the solution and the σ_c according to the following formula.

$$K = \frac{\sigma_c [1 - 0.019(T_0 - 25)]}{G_p} [cm^{-1}], \quad (5)$$

6. CONCLUSION

Maintaining ideal growing conditions guarantees the final quality and quantity of the grown product and the reusability of the soil for the next growing cycles. By using the STEM-01, common cultivation mistakes such as overwatering or underwatering and overfertilization or lack of fertilizers can be avoided. In larger applications, monitoring water and maintaining ideal irrigation will result in less water consumption, higher yields, greater financial savings, and environmental sustainability. In a sample calibration of soil water content sensor, the MAPE (mean absolute percentage error) was found to be 8.2 % which is an acceptable error in volumetric water content measurement. The accuracy of the conductivity measurement depends mainly on its correct calibration. In order to suppress the polarization effect and to maintain correct results in the long term, alternating excitation was used for the EC sensor and the electrodes were chosen as titanium. The designed module will be part of a larger autonomous system that can control irrigation and fertilization based on the data provided by this module.

ACKNOWLEDGMENT

This work was supported by Brno University of Technology and was carried out with the support of the project FEKT-S-20-6205 Research in automation, cybernetics and artificial intelligence for Industry 4.0.

REFERENCES

- [1] Bilskie, Jim. "Soil Water Status: Content and Potential." Campbell Scientific, 2001. <https://s.campbellsci.com/documents/es/technical-papers/soilh20c.pdf>
- [2] METER. Soil electrical conductivity: The complete guide to measurements. [online] Available at: <https://www.metergroup.com/en/meter-environment/education-guides/soil-electrical-conductivity-complete-guide-measurement> [Accessed 8 March 2022].