



# BRNO UNIVERSITY OF TECHNOLOGY

VYSOKÉ UČENÍ TECHNICKÉ V BRNĚ

## FACULTY OF ELECTRICAL ENGINEERING AND COMMUNICATION

FAKULTA ELEKTROTECHNIKY  
A KOMUNIKAČNÍCH TECHNOLOGIÍ

## DEPARTMENT OF TELECOMMUNICATIONS

ÚSTAV TELEKOMUNIKACÍ

## ACTIVE NOISE CANCELLING HEADPHONES

SLUCHÁTKA S AKTIVNÍM POTLAČENÍM ZVUKU

### BACHELOR'S THESIS

BAKALÁŘSKÁ PRÁCE

### AUTHOR

AUTOR PRÁCE

Viliam Krištof

### SUPERVISOR

VEDOUCÍ PRÁCE

doc. Ing. Jiří Schimmel, Ph.D.

BRNO 2024

# Bakalářská práce

bakalářský studijní program **Audio inženýrství**  
specializace Zvuková produkce a nahrávání  
Ústav telekomunikací

**Student:** Viliam Krištof

**ID:** 240171

**Ročník:** 3

**Akademický rok:** 2023/24

## NÁZEV TÉMATU:

### Sluchátka s aktivním potlačením zvuku

#### POKYNY PRO VYPRACOVÁNÍ:

Prostudujte metody aktivního potlačení hluku vhodné pro použití ve sluchátkách. Realizujte prototyp sluchátek se zabudovanými snímacími mikrofony a nezbytnými obvody a pomocí simulátoru hlavy a torza proveďte měření charakteristik sluchátka a zabudovaných mikrofonů. Zvolte vhodnou platformu pro implementaci aktivního potlačení hluku a navrhnete vhodnou metodu. Následně metodu implementujte, realizujte prototyp celého systému aktivního potlačení hluku a proveďte jeho ověření.

#### DOPORUČENÁ LITERATURA:

- [1] SNYDER, Scott D. Active Noise Control Primer (Modern Acoustics and Signal Processing). 1. Springer, 2012. ISBN 978-1461264378.
- [2] HÄNSLER, Eberhard a SCHMIDT, Gerhard. Acoustic echo and noise control: a practical approach. Hoboken: John Wiley, 2004. ISBN 978-0-471-45346-8.

**Termín zadání:** 5.2.2024

**Termín odevzdání:** 28.5.2024

**Vedoucí práce:** doc. Ing. Jiří Schimmel, Ph.D.

**doc. Ing. Jiří Schimmel, Ph.D.**  
předseda rady studijního programu

#### UPOZORNĚNÍ:

Autor bakalářské práce nesmí při vytváření bakalářské práce porušit autorská práva třetích osob, zejména nesmí zasahovat nedovoleným způsobem do cizích autorských práv osobnostních a musí si být plně vědom následků porušení ustanovení § 11 a následujících autorského zákona č. 121/2000 Sb., včetně možných trestněprávních důsledků vyplývajících z ustanovení části druhé, hlavy VI. díl 4 Trestního zákoníku č.40/2009 Sb.

## **ABSTRACT**

Active noise cancelling technology for headphones is becoming increasingly popular and it has several advantages over passive noise reduction. It is one of the key elements for a better listening experience and safer volume levels for users using the headset in noisy environments. ANC technology used in headphones is performed by various methods which utilize either analog, digital or hybrid domain for achieving effective noise reduction. The goal of this bachelor is to study the ANC technology, methods and topologies used for the headphones and to build and evaluate a functional ANC headset prototype.

## **KEYWORDS**

Active noise cancelling, ANC headphones, noise reduction, static filtering

## **ABSTRAKT**

Technológia aktívneho potlačenia hluku (Active noise cancelling - ANC) pre slúchadlá je čoraz viac populárnejšia a má nesporne niekoľko výhod oproti pasívnemu potlačeniu hluku. Je to jeden z kľúčových prvkov k dosiahnutiu lepšieho a bezpečnejšieho počúvania v hlučnom prostredí. Aktívne potlačenie hluku v slúchadlách je realizované viacerými metódami, ktoré používajú analógové, digitálne či hybridné prevedenie pre dosiahnutie efektívneho potlačenia hluku. Cieľom tejto bakalárskej práce je preštudovať technológiu aktívneho potlačenia hluku, jej metodiku a topológie používané pre slúchadlá a postaviť a zhodnotiť funkčný prototyp ANC slúchadiel.

## **KĽÚČOVÉ SLOVÁ**

Aktívne potlačenie hluku, ANC slúchadlá, potláčanie hluku, statické filtrovanie

---

## ROZŠÍŘENÝ ABSTRAKT

Táto bakalárska práca sa zaoberá technológiou aktívneho potlačenia hluku (Active noise cancelling - ANC), porovnaním rôznych topológií ANC slúchadiel používaných na trhu a vytvorením funkčného prototypu na základe požadovaných meraní.

Hlavnými cieľmi tejto práce sú:

- (a) preštudovanie technológie aktívneho potlačenia hluku v slúchadlách,
- (b) meranie požadovaných charakteristík slúchadiel a mikrofónov,
- (c) návrh funkčného prototypu založenom na vývojovom kite AS3435 od rakúskej spoločnosti AMS [1] a porovnať rôzne vývojové platformy, ktoré sú v súčasnosti dostupné na trhu,
- (d) výber metódy aktívneho potlačenia hluku pre vybranú vývojovú platformu,
- (e) implementácia metódy na vybranej platforme,
- (f) vyhodnotenie prototypu slúchadiel ANC.

Podľa základných častí ANC slúchadiel a ich analýzy bol navrhnutý a zostrojený prototyp so štyrmi mikrofónmi MEMS<sup>1</sup>, ktoré si vyžadovali vlastný návrh dosky plošných spojov pre vnútorné a vonkajšie mikrofóny. Z technických a praktických dôvodov je technológia ANC realizovaná pomocou slúchadiel s náušníkmi okolo uší, hoci v súčasnosti nie sú neobvyklé na trhu aj ANC slúchadlá do uší.

V prvej kapitole sú uvedené teoretické základy technológie ANC, rozdiel medzi pasívnym a aktívnym potlačením hluku, rozbor troch štandardných topológií ANC: spätnoväzbová (Feedback), dopredná (Feed-forward) a hybridná (Hybrid). Pre realizáciu ANC je nutný návrh filtra, ktorý kompenzuje nedostatky komponentov (jednoduché obrátenie polarity prichádzajúceho hluku by bolo nepostačujúce pre dosiahnutie žiadanej úrovne potlačenia hluku). Tento filter sa najčastejšie realizuje buď staticky (jeden fixný filter navrhnutý na základe meraní, ktorý sa už ďalej nemení) alebo adaptívne (systém vyberá zo sady baniek filtrov prípadne kompletne mení jeho koeficienty). Ďalej je rozoberaný význam ANC v slúchadlách a rozdelenie všetkých potrebných komponentov a ich podrobnejší popis pre funkčné ANC slúchadlá. Medzi tieto komponenty patria najmä: snímací mikrofón, signálový procesor, zosilňovač a slúchadlá s reproduktormi. V závere kapitoly je zhrnuté porovnanie analógových, digitálnych a hybridných riešení pre realizáciu technológie ANC a taktiež metódy filtrácie.

Druhá kapitola obsahuje najdôležitejšiu časť, najmä na začiatku tvorby prototypu, a to dôkladný výber vývojovej platformy z dostupných alternatív na trhu. Platforma určuje nielen smer ďalšieho vývoja ale taktiež hranice možností vývoja prototypu. Výber mikrofónov je závislý od koncových požiadaviek. V práci sú rozobrané dva najčastejšie používané typy a na základe ich porovnania je vybraný konkrétny typ mikrofónu - MEMS. Kapitola obsahuje taktiež zdôvodnenie výberu filtračného algoritmu. Vybranou platformou pre tento

---

<sup>1</sup>Micro-Electro-Mechanical System.

prototyp bol analógový vývojový kit AS3435 od spoločnosti AMS.

V tretej kapitole sú analyzované výsledky všetkých počiatkových meraní, ktoré sú nevyhnutné na vytvorenie funkčného prototypu, najmä návrh filtra podľa [2], ktorý poskytuje adekvátne výsledky potlačenia šumu. Tieto merania obsahujú frekvenčnú a fázovú odozvu meničov slúchadiel, mikrofónov a pasívneho útlmu slúchadiel. Pri meraní prototypu boli použité rôzne metódy na meranie frekvenčnej a fázovej odozvy všetkých komponentov. Niektoré merania sa ukázali ako vyhovujúce a niektoré sa museli merať znovu iným spôsobom, čo predĺžilo proces vývoja prototypu. Vo výsledku dokázali namerané hodnoty poskytnúť údaje pre výpočet filtra, ktoré boli neskôr využité pri návrhu filtra. Navrhnuté analógové filtre sa zmerali a porovnali so simuláciami. Aktívne potláčanie hluku bolo realizované statickou filtráciou pomocou analógových filtrov. Táto metóda sa otestovala na dvoch topológiách ANC: Feedback (Spätnoväzbová) a Feed-forward (Dopredná) a bola porovnaná s dvoma komerčne dostupnými riešeniami na trhu. Kapitola zahŕňa taktiež zhodnotenie návrhu analógového filtra a meranie potlačenia hluku v slúchadlách. Konečný prototyp ANC slúchadiel je porovnaný s inými dostupnými ANC slúchadlami na trhu.

Výsledky hodnotenia prototypu ANC slúchadiel napriek nespočetnému množstvu meraní a analýze nezodpovedali požadovanému a očakávanému aktívnemu potlačeniu hluku. Keďže za nedostatočným výkonom aktívneho potlačenia môže byť mnoho príčin, je veľmi dôležité analyzovať celý proces výroby prototypu a navrhnúť riešenia, ktoré by mohli ANC slúchadlá v budúcnosti vylepšiť a zabezpečiť ich lepšiu výkonnosť. Po prvé, analógové riešenie má mnoho výhod, je ekonomickejšou možnosťou a nevyžaduje žiadne AD/DA prevodníky. Bohužiaľ, akékoľvek zmeny frekvenčnej a fázovej odozvy analógového filtra nie je možné realizovať jednoducho a rýchlo. Digitálny filter by pravdepodobne bol oveľa flexibilnejší počas celého procesu tvorby prototypu. To však neznamená, že analógovým filtrom sa treba za každú cenu vyhýbať, ale je jednoducho výhodnejšie z hľadiska vývoja používať digitálnu doménu, pretože to výpočtový výkon v dnešnej dobe umožňuje. Po druhé, v dutinách slúchadiel vzniká nezvyčajná rezonancia na nízkych frekvenciách, ktorá mohla potenciálne ovplyvniť merania, a teda aj konečný návrh filtra a výkon aktívneho a pasívneho potlačenia hluku. Akustický dizajn je zjavne dôležitejší ako sa zdal a pri budúcich projektoch by sa mal brať do úvahy oveľa vážnejšie. Vybraná analógová vývojová platforma taktiež vykazovala problémy, čo mohlo potenciálne prispieť k zníženej úrovni redukcie hluku. Odporúčané riešenia na zlepšenie redukcie hluku tohto konkrétneho prototypu sú :

1. zopakovať merania a odznovu navrhnúť filtre a porovnať výsledky,
2. použiť iné slúchadlá s lepším akustickým dizajnom,
3. nahradiť analógovú platformu digitálnou platformou, ktorá by umožnila oveľa rýchlejšie a jednoduchšie vyladiť prototyp aj na konci vývoja a meraní.

KRIŠTOF, Viliam. *Sluchátka s aktivním potlačením zvuku*. Bachelor's Thesis. Brno: Brno University of Technology, Fakulta elektrotechniky a komunikačních technologií, Ústav telekomunikací, 2024. Advised by doc. Ing. Jiří Schimmel, Phd.

# Author's Declaration

**Author:** Viliam Krištof  
**Author's ID:** 240171  
**Paper type:** Bachelor's Thesis  
**Academic year:** 2023/24  
**Topic:** Sluchátka s aktivním potlačením zvuku

I declare that I have written this paper independently, under the guidance of the advisor and using exclusively the technical references and other sources of information cited in the paper and listed in the comprehensive bibliography at the end of the paper.

As the author, I furthermore declare that, with respect to the creation of this paper, I have not infringed any copyright or violated anyone's personal and/or ownership rights. In this context, I am fully aware of the consequences of breaking Regulation § 11 of the Copyright Act No. 121/2000 Coll. of the Czech Republic, as amended, and of any breach of rights related to intellectual property or introduced within amendments to relevant Acts such as the Intellectual Property Act or the Criminal Code, Act No. 40/2009 Coll. of the Czech Republic, Section 2, Head VI, Part 4.

Brno .....

.....

author's signature<sup>†</sup>

---

<sup>†</sup>The author signs only in the printed version.

## ACKNOWLEDGEMENT

I would like to thank my supervisor doc. Ing. Jiří Schimmel, Ph.D. for his professional help not only during the measurements but also for his willingness and time he gave me during the consultations. Many thanks belong also to Rowan Williams, Horst Gether, Ing. Vojta Panenka and Ing. Alexandr Otáhal, Ph.D. who took the time and enthusiasm to give me valuable advice and help. Last but not least, I would like to thank my family and friends who stood by my side and supported me throughout my studies.

# Contents

|   |           |
|---|-----------|
| <b>Introduction</b>                           | <b>13</b> |
| <b>1 Active Noise Cancelling</b>              | <b>14</b> |
| 1.1 Passive Noise Cancelling . . . . .        | 15        |
| 1.2 Active Noise Cancelling . . . . .         | 16        |
| 1.3 ANC Topologies . . . . .                  | 16        |
| 1.3.1 Feed-forward ANC . . . . .              | 17        |
| 1.3.2 Feedback ANC . . . . .                  | 18        |
| 1.3.3 Hybrid ANC . . . . .                    | 19        |
| 1.4 Microphone . . . . .                      | 21        |
| 1.4.1 ECM . . . . .                           | 21        |
| 1.4.2 MEMS . . . . .                          | 21        |
| 1.5 Signal Processor Implementation . . . . . | 23        |
| 1.5.1 Analog Signal Processor . . . . .       | 23        |
| 1.5.2 Digital Signal Processor . . . . .      | 23        |
| 1.5.3 Hybrid Signal Processor . . . . .       | 23        |
| 1.6 Adaptive Filtering . . . . .              | 24        |
| 1.7 Fixed Filtering . . . . .                 | 24        |
| <b>2 Selected Applied Methodology</b>         | <b>26</b> |
| 2.1 Headset . . . . .                         | 26        |
| 2.2 Microphones . . . . .                     | 27        |
| 2.3 Signal Processor . . . . .                | 28        |
| 2.3.1 Digital Evaluation Kit . . . . .        | 28        |
| 2.3.2 Analog Evaluation Kit . . . . .         | 28        |
| 2.4 Filtering Algorithm . . . . .             | 30        |
| <b>3 Practical Results</b>                    | <b>31</b> |
| 3.1 Feed-forward Characterization . . . . .   | 31        |
| 3.1.1 Passive Attenuation . . . . .           | 32        |
| 3.1.2 Drivers . . . . .                       | 35        |
| 3.1.3 Microphones . . . . .                   | 36        |
| 3.2 Feedback Characterization . . . . .       | 37        |
| 3.3 Filter Calculation . . . . .              | 40        |
| 3.3.1 Feed-forward Filter . . . . .           | 40        |
| 3.3.2 Feedback Filter . . . . .               | 41        |
| 3.4 Filter Simulation . . . . .               | 42        |

|       |  |           |
|-------|--|-----------|
| 3.5   | Filter Soldering . . . . .                     | 45        |
| 3.6   | Filter Evaluation . . . . .                    | 45        |
| 3.7   | Noise Cancelling Evaluation . . . . .          | 47        |
| 3.7.1 | Evaluation Board Assessment . . . . .          | 47        |
| 3.7.2 | Active Noise Cancelling Evaluation . . . . .   | 49        |
| 3.8   | Comparison with other ANC headphones . . . . . | 52        |
|       | <b>Conclusion</b>                              | <b>54</b> |
|       | <b>Bibliography</b>                            | <b>56</b> |
|       | <b>Symbols and abbreviations</b>               | <b>58</b> |
|       | <b>List of appendices</b>                      | <b>59</b> |
| A     | Datasheet of MEMS microphone                   | 60        |
| B     | BOM for analog filters                         | 63        |
| C     | Schematic of AS3435 evaluation kit             | 64        |
| D     | Contents of Electronic Appendix                | 72        |

# List of Figures

|      |   |    |
|------|---|----|
| 1.1  | General ANC block diagram . . . . .                             | 14 |
| 1.2  | Ideal noise cancellation . . . . .                              | 16 |
| 1.3  | FF ANC block diagram . . . . .                                  | 17 |
| 1.4  | FF ANC headset performance . . . . .                            | 18 |
| 1.5  | FB ANC block diagram . . . . .                                  | 18 |
| 1.6  | FB ANC headset performance . . . . .                            | 19 |
| 1.7  | Hybrid ANC block diagram . . . . .                              | 20 |
| 1.8  | Hybrid ANC headset performance . . . . .                        | 20 |
| 1.9  | MEMS microphone construction . . . . .                          | 22 |
| 1.10 | Bottom port MEMS vs. Top port MEMS . . . . .                    | 22 |
| 2.1  | Selected applied methodology block scheme . . . . .             | 26 |
| 2.2  | Available headsets for prototyping . . . . .                    | 27 |
| 2.3  | PCBs for MEMS microphones . . . . .                             | 27 |
| 2.4  | AMS Evaluation Kit, taken from [1]. . . . .                     | 29 |
| 3.1  | Frequency response of the headset . . . . .                     | 32 |
| 3.2  | Phase response of the headset . . . . .                         | 32 |
| 3.3  | In-box measurement . . . . .                                    | 33 |
| 3.4  | Passive attenuation measurement block scheme . . . . .          | 33 |
| 3.5  | Passive attenuation of two available headsets . . . . .         | 34 |
| 3.6  | Passive attenuation measurement comparison . . . . .            | 35 |
| 3.7  | Frequency and phase response of a driver block scheme . . . . . | 35 |
| 3.8  | Drivers measurement comparison . . . . .                        | 36 |
| 3.9  | Frequency and phase response of MEMS block scheme . . . . .     | 36 |
| 3.10 | FF ANC microphones measurement setup . . . . .                  | 38 |
| 3.11 | Microphones measurement comparison . . . . .                    | 38 |
| 3.12 | Open loop measurement block scheme . . . . .                    | 39 |
| 3.13 | Open loop measurement - frequency response . . . . .            | 39 |
| 3.14 | Open loop measurement - phase response . . . . .                | 39 |
| 3.15 | FF filter gain calculation . . . . .                            | 41 |
| 3.16 | FF filter phase calculation . . . . .                           | 41 |
| 3.17 | FB filter gain calculation . . . . .                            | 42 |
| 3.18 | FB filter phase calculation . . . . .                           | 42 |
| 3.19 | FF filter simulation tool in AMS . . . . .                      | 43 |
| 3.20 | FF filter simulation . . . . .                                  | 43 |
| 3.21 | FB filter simulation . . . . .                                  | 44 |
| 3.22 | FB oscillation warning tool . . . . .                           | 44 |
| 3.23 | FB analog filter . . . . .                                      | 45 |

|      |  |    |
|------|--|----|
| 3.24 | FF analog filter . . . . .   | 45 |
| 3.25 | Filters evaluation . . . . .   | 46 |
| 3.26 | Active Noise Cancelling on evaluation board . . . . .  | 48 |
| 3.27 | (a) Occasional distortion of the output harmonic signal. (b) Occasional im-<br>pulse appearing in the output signal. . . . . | 48 |
| 3.28 | Monitor mode on evaluation board . . . . .   | 49 |
| 3.29 | ANC evaluation block scheme . . . . .  | 49 |
| 3.30 | PNC evaluation . . . . .   | 50 |
| 3.31 | FF ANC evaluation . . . . .  | 51 |
| 3.32 | FB ANC evaluation . . . . .  | 51 |
| 3.33 | Active noise reduction of FF and FB . . . . .  | 52 |
| 3.34 | ANC comparison . . . . .   | 53 |

# Introduction

This bachelor thesis deals with active noise cancelling technology (ANC), a comparison of its different topologies, and building a functional prototype based on required measurements.

The main goals of this thesis are:

- (a) research of the active noise cancelling technology in headphones,
- (b) measurements of the required characteristics of the headphones and microphones,
- (c) proposal of a functional prototype based on evaluation kit AS3435 from Austrian company AMS [1] and to compare various potential builds that are available on the market at the moment,
- (d) selection of a method of active noise cancelling for a chosen evaluation kit,
- (e) implementation of a method on the chosen platform,
- (f) evaluation of the ANC headphones prototype.

This prototype also involves the implementation of MEMS<sup>1</sup> microphones which required custom PCBs for inner and outer microphones. Due to technical and practical reasons, ANC technology is fitted on over-ear headset although, nowadays, it is not uncommon to see in-ear ANC solutions on the market.

The first chapter establishes a theoretical foundation of ANC technology, the difference between passive and active noise cancelling, an evaluation of three industry-standard ANC topologies, a contrast between static and adaptive filtering, the purpose of ANC in headphones, a breakdown of all necessary components for a functional ANC headset and comparison of analog, digital and hybrid solutions for ANC controllers.

The second chapter includes the most important part, especially at the beginning of prototyping, a careful selection of an evaluation kit from available alternatives on the market, a choice of microphones, a selection of filtering algorithm, and a comparison of two available headsets for this particular prototype.

In the third chapter there are analyzed the results of all the initial measurements that are essential for building a functional prototype, particularly the filter design, according to the [2], that derives adequate results of noise cancelling. These measurements contain the frequency and phase response of the headset drivers, microphones, and passive attenuation of the headset. It also includes the evaluation of the analog filter design and measurements of the noise reduction in the ANC headset. The final ANC headset prototype is also being compared to other available ANC headphones on the market.

In the conclusion, there are summarized the practical results, measurements, evaluation of the functionality of the prototype, and potential continuation for the future.

---

<sup>1</sup>Micro-Electro-Mechanical System.

# 1 Active Noise Cancelling

Active Noise Cancelling, also known as "ANC", is a technology that connects various scientific fields mainly mechanical engineering, acoustics, audio and signal processing and electrical engineering. It improves the listening experience, and intelligibility of conversations and the user can experience an increase in signal-to-noise ratio. Compared to ordinary over-ear headphones (without ANC) the system requires a power source usually a small battery for microphones, amplifiers and digital or analog processor. Although the word "active" might evoke that the system is just an electric circuit, the reality is, that passive noise cancellation is also a significant part of active noise cancellation. According to the [3] passive noise cancellation plays a crucial role because to achieve decent ANC performance it is necessary to avoid air leakages as much as possible. This is important, particularly for FF (Feed-forward) topology, which will be discussed later.

An interesting insight for ANC is, that either headset, on-ear or in-ear systems can reduce to some extent the occlusion effect [4], the echo-like sensation in the ear canal, which many users might find helpful and more pleasant especially during calls or while talking to someone.

General ANC headphones would normally include [4]:

- microphone
- signal processor
- amplifier
- driver (loudspeaker)

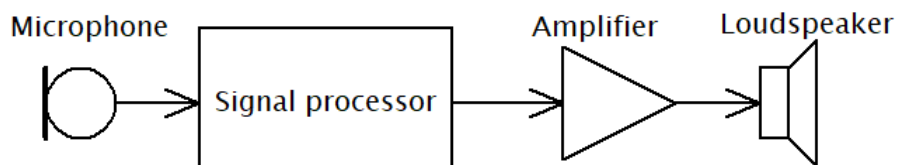

Fig. 1.1: General ANC block diagram, taken from [4] and modified.

One microphone or more is required for capturing the noise that is sent to the signal processor. The position of the microphone determines not only the topology but also its effectiveness towards capturing the noise as well as rejection of any wind-induced noise. The signal processor either analog or digital then inverts and filters the signal that is sent to the amplifier and a loudspeaker.

## 1.1 Passive Noise Cancelling

Although this thesis does not particularly deal with passive noise cancelling it is worth mentioning its importance in ANC and to prove how significant it might be especially at higher frequencies. In a simplified manner, we could assume that because the biggest friction is at  $1/4$  of wavelength from the surface [5], passive noise cancellation should have a noticeable effect from around 3 kHz as stated in Equation (1.1) in this case, for 3 cm thick ear pads,

$$f = \frac{c_0}{\lambda} = \frac{343\text{ms}^{-1}}{4 \times 0.03\text{m}} \approx 2.86 \text{ [kHz]}, \quad (1.1)$$

where  $f$  is a frequency,  $c_0$  the speed of sound in air at  $20^\circ\text{C}$  (degrees Celsius) and  $\lambda$  is the wavelength. However, the passive noise reduction might happen much sooner as it is described in Chapter 3 where passive attenuation of the headphones will be discussed further in comparison of two different measured headphones.

Even though passive noise cancelling is still used nowadays in many different applications either due to price or practical reasons, active noise cancelling seems to be the only option when it comes to noise cancellation of low frequencies in enclosed spaces for instance, in headphones.<sup>1</sup> There are two main approaches how to passively reduce noise [6]:

- a) absorption of noise
- b) isolation from a noise source.

The first method provides a sound reduction by absorbing the sound and converting it into heat. The second method means either to eliminate air leaks or any vibrations. None of the methods are superior to the other, the best results are achieved when both of them are implemented in a system together. In our case, ANC headphones, both approaches are combined together in ear pads. They are usually made from elastic and soft materials where elasticity provides the isolation and an adaptation to different shapes of ears or head whereas the material, that absorbs the sound well, converts the sound into heat. The choice of the material also affects the fact, that ear pads should be comfortable and pleasant to wear, but that will not be discussed in this thesis.

---

<sup>1</sup>Unless we can provide a thick isolation with high surface density.

## 1.2 Active Noise Cancelling

Active noise cancelling, in simple words, works by combining two signals with an inverted phase (by  $180^\circ$ ) which theoretically should result in silence. We are able to do that because sound waves are mostly linear in the range of pressure safe to our hearing [4]. With the application of a method of superposition, the theoretical result of noise cancelling should look like in Figure 1.2 where  $A$  stands for amplitude and a  $t$  for time.

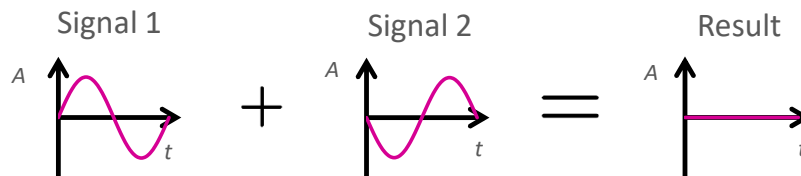

Fig. 1.2: Ideal noise cancellation.

This is of course the ideal case that in practice is unattainable and there will always be a residual sound left after a noise cancellation. To get a noise reduction greater than 12 dB, the noise cancelling signal must match the original noise signal by less than 2 dB amplitude and 0.25 rad phase error. Considering the imperfection of real components in ANC headphones such as drivers, microphones, acoustic behaviour of the headset as well as the human ear, we are facing a very complex problem that requires a precise filter design [4]. ANC headset should be able to reduce the noise (with properly designed passive noise reduction) up to 3 kHz for Feed-Forward ANC and up to 1 kHz for Feedback ANC [3]. The reason for this limitation is generally behaviour and characteristics of sound that behave independently in space. From the perspective of wavelength, it means that any two chosen points are moving closer together for low frequencies while further apart for higher frequencies [4]. This might sound counter-intuitive, but it is important to emphasise that higher frequencies usually do not have even directional characteristics. Lower frequencies, conversely, are easier to cancel out since the direction, in which the noise is coming is not as important. There are already different technologies on the market that focus on targeting this issue like beam forming or using multiple microphones [7]. However, that is beyond the scope of this work.

## 1.3 ANC Topologies

ANC systems used nowadays are divided into three main topologies:

- a) Feed-forward (FF) ANC
- b) Feedback (FB) ANC
- c) Hybrid ANC

The main difference between the FF and FB is the placement of the microphone while the hybrid topology is their combination. All three topologies will be analysed further in the following subsections.

### 1.3.1 Feed-forward ANC

Feed-forward ANC is typical for its position of the microphone at the outer layer of the headset. It means, that a noise is detected by the microphone before its arrival to the headphone as shown in Figure 1.3.

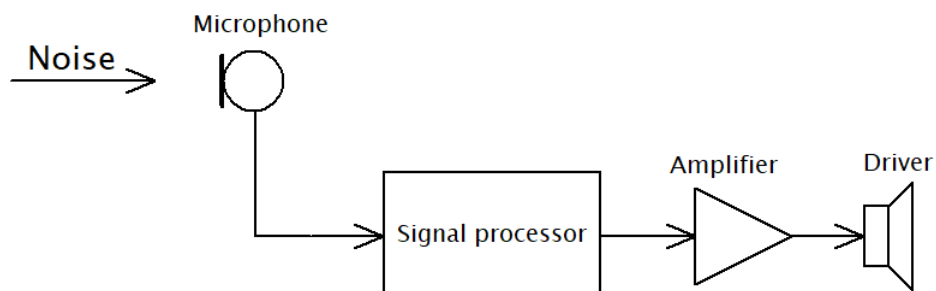

Fig. 1.3: FF ANC block diagram, taken from [4] and modified.

Due to the physical distance between the microphone and the headphone cup, there is time to process the signal before the noise arrives at the headphone cup. Sadly, FF ANC is dependent on the arrival angle of the noise. For higher frequencies it means that the system is required to do an impossible task - filter the noise that came to the ear cup before to the microphone. It also should be emphasised that FF topology is quite vulnerable to wind or wind-induced noise as a result of the microphone's position [4]. In FF ANC is really important to avoid microphone-to-speaker coupling by providing enough isolation and an ear cup that fits well to the listener. In the Figure 1.4 is shown the attenuation performance of the FF ANC headset according to [4].

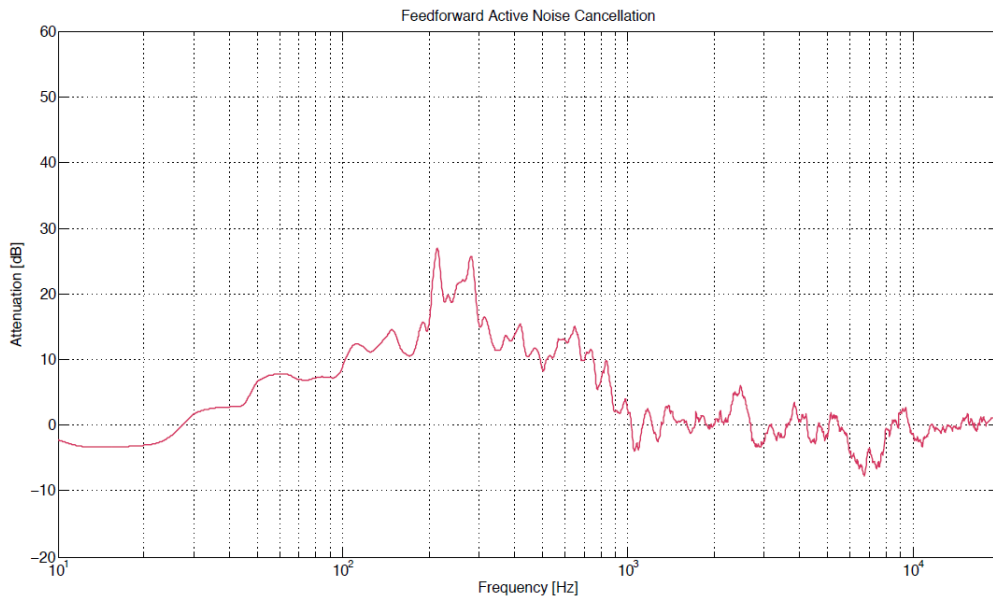

Fig. 1.4: FF ANC headset performance, taken from [4].

### 1.3.2 Feedback ANC

Feedback ANC is, on the other hand, typical for its position of the microphone on the inner layer of the headset, which means, it is located in the ear cup as shown in Figure 1.5.

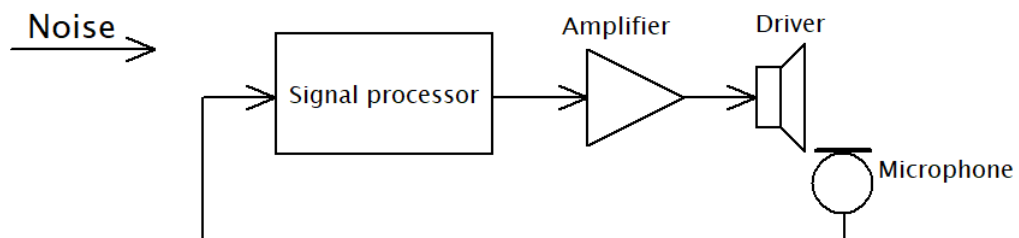

Fig. 1.5: FB ANC block diagram, taken from [4] and modified.

As has been said before, FF ANC is quite vulnerable to wind-induced noise, FB ANC tackles this problem very effectively since it is isolated by the ear cup. FB ANC is also able to compensate for air leakages compared to FF ANC, where any leakage causes a dramatic reduction in noise-cancelling performance. Another difference between FF and FB ANC is their performance [3]. Whereas FF ANC shows better peak performance and has wider bandwidth, FB has better low-frequency performance and more flat distribution across the frequency spectrum, see Figure 1.6.

Considering the location of the microphone two problems arise.

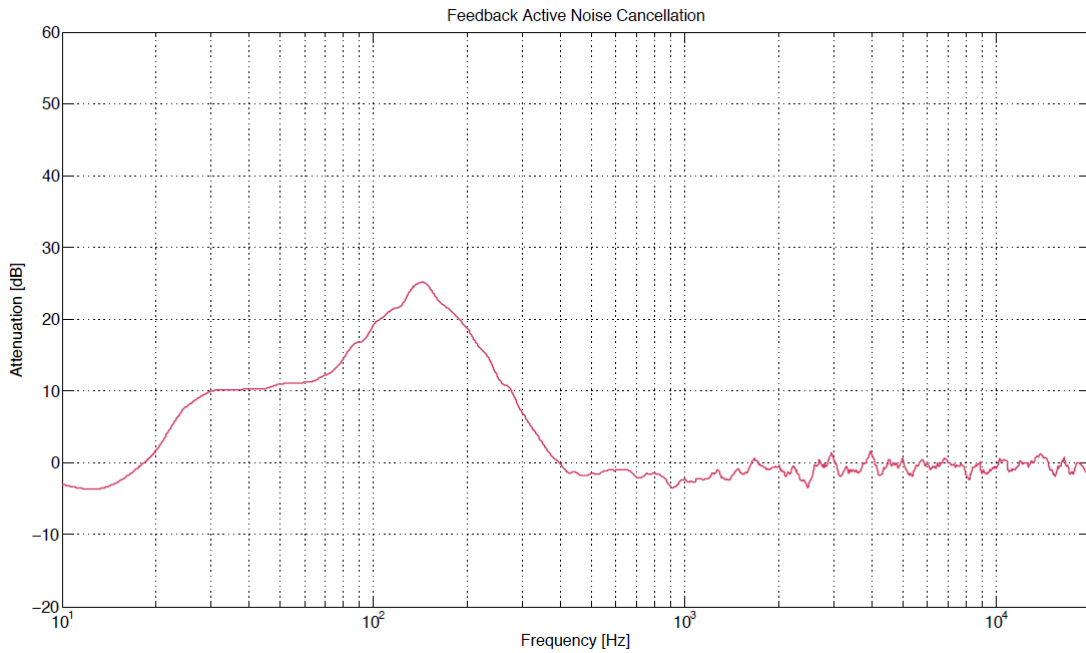

Fig. 1.6: FB ANC headset performance, taken from [4].

Firstly, the microphone cannot differentiate the music or sound played by the speaker and the noise coming from the outside. Thus, the system is trying to cancel out also the music we are playing through the speaker. According to [3], this phenomenon, low-frequency loss, is common in FB ANC. Despite this issue, there is a simple solution. The music signal could be subtracted from the microphone signal. This means that the signal coming into the noise cancelling processor has to be filtered [4]. Easier said than done, this problem could also be eliminated by adding an equaliser with bass boost, so the low-frequency loss is compensated. This, however, provides only a quick-fix solution due to the amplifiers that might not have enough headroom for the signal [3].

Secondly, the FB system is likely to create acoustic feedback, also known as the Larsen effect. To avoid, this effect the feedback control has to be added to the system [4]. There are several options. Automatic gain control, which adjusts the gain of the audio in case of acoustic feedback, integrates a notch filter into a signal chain that targets specific frequencies and reduces their gain or uses an adaptive active noise cancelling that is discussed later in Section 1.6.

### 1.3.3 Hybrid ANC

Hybrid ANC is a combination of the FF ANC and FB ANC. It fuses all of the advantages and compensates the drawbacks of feedback and feed-forward technologies although, with an increase in the system complexity and obviously, a price. As shown in Figure 1.7, the headset

requires an additional processor and two microphones per channel.

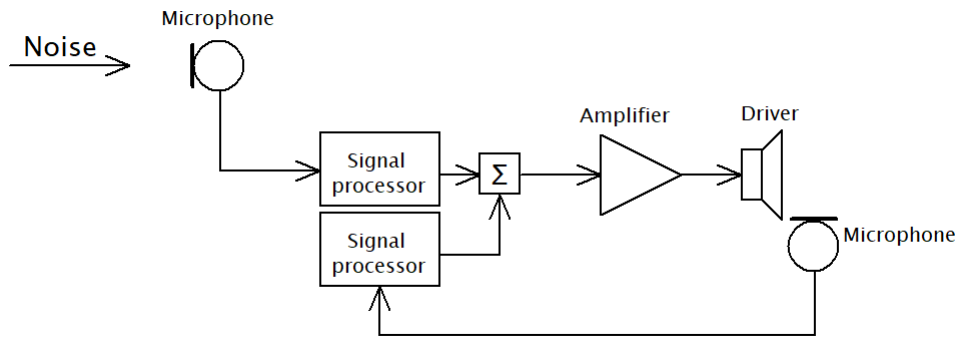

Fig. 1.7: Hybrid ANC block diagram, taken from [4] and modified.

This system is commonly used among premium headsets due to its performance. It has well over 30dB peak noise reduction from 20Hz by up to 3kHz [3]. This level of attenuation would not be possible with standalone either FF ANC or FB ANC. The hybrid ANC performance is shown in Figure 1.8.

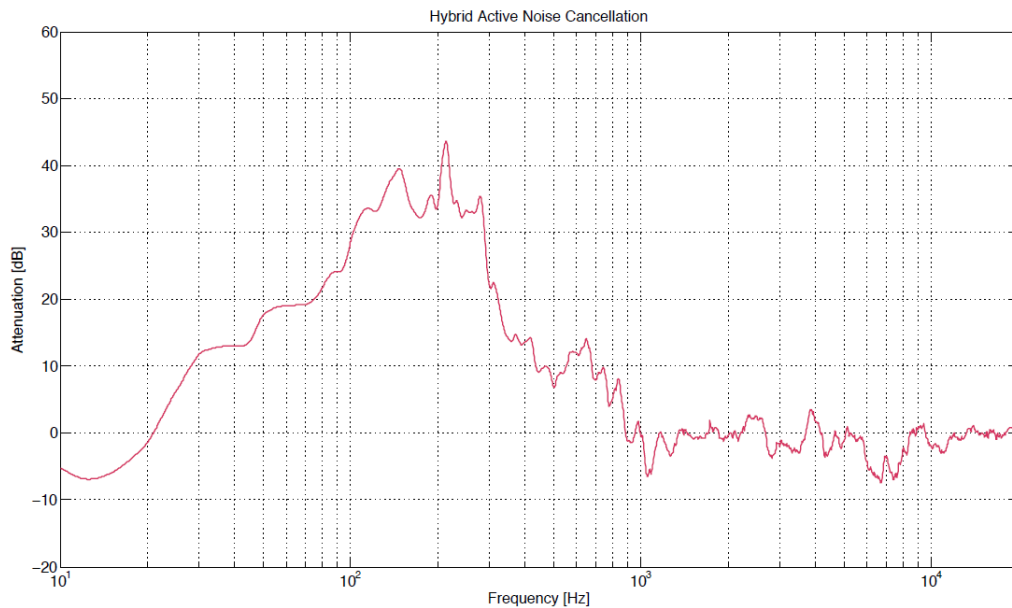

Fig. 1.8: Hybrid ANC headset performance, taken from [4].

## 1.4 Microphone

This section deals with the choice of the microphone for an ANC headset. In order to choose a microphone for the ANC headset there must be taken few requirements into consideration. Firstly, the microphone has to be small, have wide directional characteristics, preferably omnidirectional, and have a reasonably flat frequency response. Secondly, it should have low power consumption and possibly be waterproof to some extent. With all of these conditions, we are usually left with only two options:

- a) ECM microphone (Electret condenser microphone)
- b) MEMS microphone

### 1.4.1 ECM

Electret condenser microphone also known as ECM is normally the first and easiest option, especially for prototyping or projects like this one. It has an option for IPX rating because of its construction, which might be useful in FF ANC considering that the user might wear the headphones outside while raining. Due to its size it is much easier to do the testing, solder it to the circuit or manipulate it on a breadboard.

Although it might be easier to manipulate with this type of microphone in the end, a lot more space is necessary for it in the final design. For the feedback microphone, it could be very difficult to fit the microphone in the ear cup. It usually also needs a higher voltage supply and it does not have as flat frequency response as the MEMS does. ECM is a much older technology compared to MEMS which is being used in so many applications nowadays.

ECM operates on a very similar principle as an ordinary condenser microphone, capacitance changes between the conductive plate and the diaphragm as it moves by the sound pressure are amplified and sent further to the circuit as a voltage signal, but in this case, the diaphragm is a different material and capacitor voltage variations are amplified by a JFET (junction field-effect transistor) that is an internal part of the microphone [8].

### 1.4.2 MEMS

Micro-Electro-Mechanical System also known as MEMS is a special type of microphone that works on a very similar principle to an ECM. It has a sensor that picks up the sound by changes in capacitance, it contains a semiconductor that amplifies the signal which is usually the Application-Specific Integrated Circuit (ASIC). and a sound port that allows a sound to move the diaphragm as shown in Figure1.9.

The main difference between ECM and MEMS is in the size and the manufacturing process of the microphone. They are made with technology that is used for integrated circuits

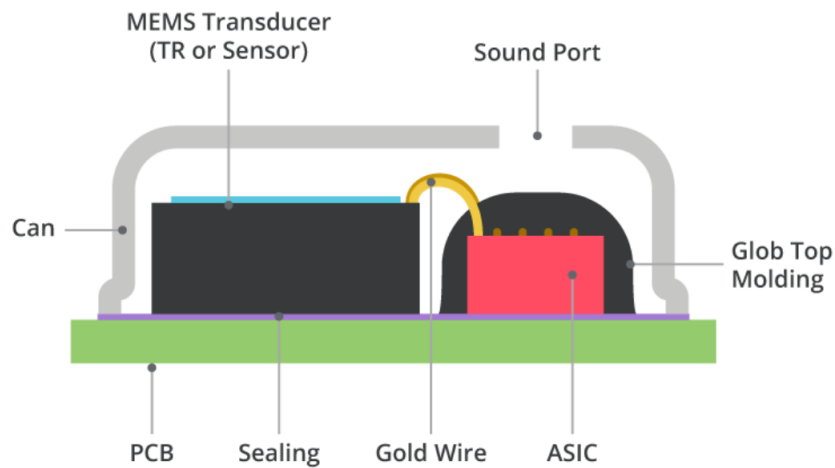

Fig. 1.9: MEMS microphone construction, taken from [8].

production [8]. MEMS microphones could be either digital, that has a built-in analog-to-digital converter (ADC), or analog that could be connected directly to an analog circuitry. Apart from analog and digital MEMS, there are two more options to choose from. Either bottom port or top port microphone. In Figure 1.9 there is shown a top port construction. According to [9] a bottom port configuration due to a bigger back chamber, as shown in Figure 1.10 has an improved Signal-to-noise ratio (SNR) and it also enables to have a flatter frequency response.

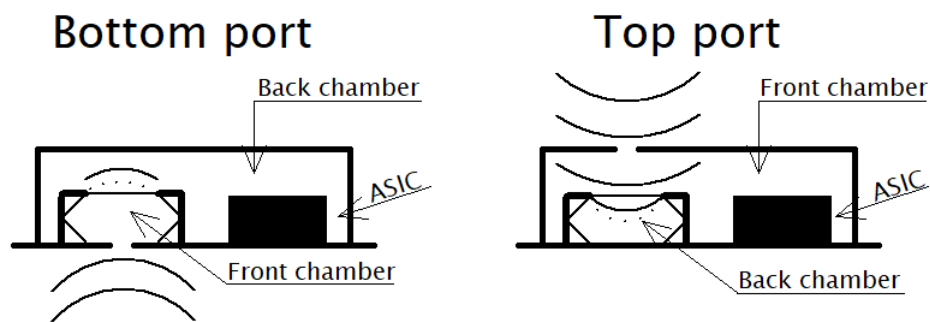

Fig. 1.10: Bottom port MEMS vs. Top port MEMS, taken from [9] and modified.

The top port on the other hand is much easier to solder as in the bottom port configuration the microphone has to be soldered and bonded well to the Printed Circuit Board (PCB) so there is no air gap.

## 1.5 Signal Processor Implementation

This section is focused on the implementation of the signal processor as it is perhaps the most important part of the ANC system. There are generally 3 types of signal processors: analog, digital and hybrid, which will be discussed further in the following subsections.

### 1.5.1 Analog Signal Processor

Analog signal processor was the first type of implementation of the active noise cancelling technology. It is perfectly capable of complex filter design, to have the desired performance of noise reduction and practically any typology of ANC could be run by an analog signal processor. However, the disadvantage of analog ANC is that it is much more difficult to adjust it during the development process once there are real components [4]. On the other hand, analog device is easier to repair and replace individual parts. There is not a need for practically any ADC (analog-to-digital converter) which helps to prevent the system from any signal distortion, quantisation noise or other issues that might appear while using A/D or D/A converters.

It has a better chance to lower the power consumption and in the end, it is much more likely to meet quality criteria that the users demand [10].

### 1.5.2 Digital Signal Processor

Digital signal processor (DSP) brings a lot of advantages to noise cancelling. It has almost limitless filtering capabilities and it offers an option to use adaptive filtering, which by analog controller would be very complicated if not impossible to do so. Yet, the choice of a digital controller, with nowadays massive computing power, still might not be ideal. Problems arise with power consumption as digital ANC controllers need usually more power than analog controllers and the DSP could introduce overall latency to the system. According to [4] time delay is fairly manageable in FF systems. Unfortunately, in FB ANC it causes a phase term that could affect the performance up to a degree that the noise reduction is not very sufficient. It is also important to keep in mind that the "limitless" computing power of a DSP is not helpful with an improper acoustic design [4].

### 1.5.3 Hybrid Signal Processor

A hybrid signal processor is a blend of an analog and digital signal processors where we could take the advantage of both systems and combine them in a way that it improves either the overall performance or makes the headphones more convenient to use. For instance, incorporating Bluetooth into the system [4].

## 1.6 Adaptive Filtering

The amount of noise reduction in ANC systems, as was mentioned earlier in Section 1.2, strictly depends on accuracy of phase and amplitude generated in comparison to an incoming sound. Thus, many ANC systems use adaptive algorithms that not only monitor the performance of noise reduction but they also update the filter in real-time based on the ambient sound [6]. This would be necessary in ANC systems where there are frequent changes in temperature, and humidity for instance in air conditioning. On a speaker/microphone, performing noise cancelling, either a mould could form or dust might accumulate, so the frequency and phase characteristics of a system change. Therefore, it is quite necessary to secure the system's performance by providing an adaptive algorithm which removes the necessity of any additional corrections after implementing the system [6]. Adaptive noise cancelling systems need at least two microphones where the first is for capturing the noise and the second microphone functions as an "error" microphone that controls the performance of a noise reduction. The block diagram would look very similar to the one in Figure 1.7 except there is just one signal processor implemented with an adaptive algorithm.

Therefore, hybrid topology does not necessarily mean that the system is adaptive. Adaptive filtering could be based on different algorithms for example: Normalised least mean square algorithm, Affine projection algorithm, Recursive least squares algorithm or Kalman algorithm [11]. The order of these algorithms is according to [11] in order of their numerical complexity which does not automatically determine their performance.

Adaptive algorithms and their in-depth analysis are beyond the scope of this thesis. The reason for that is rather simple. Although adaptive algorithms are utilized in many different applications, commercial ANC headphones apart from experimental and research purposes use fixed (static) filtering or possibly selective fixed filtering [12] which is analysed later in Section 1.7. Adaptive filters have a few disadvantages compared to fixed filtering. Firstly, there is a risk of divergence with rapid incoming noise changes. Furthermore, they require much higher computational cost which usually results in the final price of research that has to be done to satisfy the requirements of ANC headphones [12].

## 1.7 Fixed Filtering

Fixed filtering is characterized by a static filter that does not change or adapt over time. It has predetermined filter or perhaps a set of filters. In that case we might call this system a "simple adaptive" or "selective fixed filtering" as it is mentioned in [12].

The word 'static' or 'fixed' could often lead to a conclusion that the system has a passive noise reduction only, so it does not do anything actively. Furthermore, as was discussed in the previous section, fixed filtering is more common in the ANC headphones industry.

According to [12] fixed filtering is robust and has satisfying noise reduction up to a certain degree although selective fixed filtering has obviously a certain advantage over simple fixed filtering. It has a detection algorithm that monitors state changes in the environment, for instance, how noisy it is or whether the listener is moving or talking. The controller will then select a particular ANC filter set from its filter bank. This filter bank could be designed "manually" by simulating different scenarios and environments but recently deep learning or machine learning has been used for this purpose [12]. This tool could be used also for optimisation of the fitting of the headset which is important factor for performance of the ANC (Section 1.3.2).

However, in order to achieve a demanded quality and performance of the ANC system, there must be done a proper filter design regardless of selected type of filtering. Filter design for ANC headset is based on particular acoustical measurements that, if done poorly, will determine the final performance of noise cancelling. These measurements are: passive attenuation of the ear cups, frequency and phase characteristics of headset drivers and microphones. There is also one specific measurement for FB topology called an open loop measurement between driver and inner microphone [13], which will be discussed further in Chapter 2.

## 2 Selected Applied Methodology

The ANC was analysed in the previous chapter, its structure and different components that are necessary to design a functional prototype such as: microphones, signal processor, filtering algorithm and headset with drivers. In this chapter there is selected and applied particular combination of the components and method with further discussion and comparison to other potential designs.

Firstly, it would be advisable to gather all of the different combinations in one place as shown in Figure 2.1, where the pink box represents the selected combination.

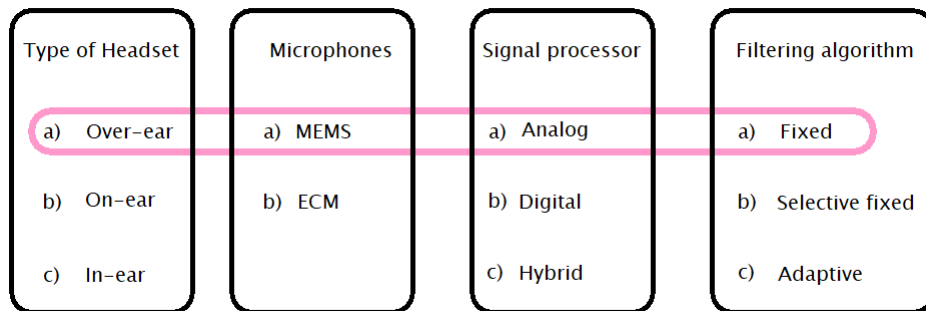

Fig. 2.1: Selected applied methodology block scheme.

Secondly, all of the parts are going to be taken apart, compared to other solutions with argumentation for the choices that have been made.

### 2.1 Headset

Choosing a type of headset for a prototype is a crucial task in terms of competence and technological capabilities. The in-ear headset did not pass these requirements due to its size. The goal of this thesis is not to make the ANC system as small as possible. Although, on-ear headsets are much bigger they are typically for lower ANC performance because they do not fit as well as over-ear headsets and they are also not very comfortable to wear.

For this particular thesis, there were available two headsets, as shown in Figure 2.2. The passive attenuation of both headsets as well as the frequency characteristics of the headset's drivers are compared in Chapter 3. For a prototype the black headset on the left side of the picture was chosen.



Fig. 2.2: Available headsets for prototyping.

## 2.2 Microphones

Two types of microphones used for ANC applications were mentioned in Section 1.4: ECM and MEMS. After considering their advantages and disadvantages, the latter was chosen for this design. Although ECM is much easier to solder and work with, MEMS usually have flatter frequency and phase response as the manufacturer provides in their data sheet [16]. Another reason was its smaller size which could be beneficial for future projects.

The bottom port configuration of MEMS from company CUI DEVICES (data sheet is provided in the Appendix A) was picked for this particular prototype. It has several benefits over top port configuration (Subsection 1.4.2). Bottom port configuration, however, involved a custom PCB design, (see Figure 2.3) and soldering on a hot plate with the application of a solder paste under the microscope (the microphone's soldering pads are smaller than 0.5mm). This particular soldering method, after all, lowered the risk of having an air gap between the PCB and microphone that could affect its acoustic performance.

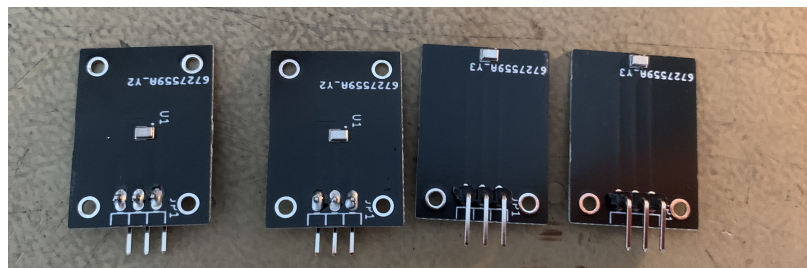

Fig. 2.3: PCBs for MEMS microphones.

## 2.3 Signal Processor

Choosing a signal processor for a prototype was probably the most important decision of all and it determined practically most of the steps of the final applied methodology. As one of the goals of this thesis is to choose a platform for the ANC implementation, there were a couple of options on the market available. Companies Sony and Qualcomm offered a software development kit (SDK) which would require a custom design of the board with all the necessary components, amplifiers, preamplifiers, A/D and D/A converters and much more, that are not as important for the goal of this project, at least for now. In the beginning, it was clear that the main focus was on the ANC system as a whole, therefore the steps to create a functional prototype had to be driven in this direction. All of that led to two final options.

### 2.3.1 Digital Evaluation Kit

Digital evaluation kit ADAU 1787Z from company Analog Devices [17] would provide practically endless signal processing capabilities, with great support either for the software or hardware and the possibility to apply adaptive filtering method for noise cancellation. Unfortunately, this option was rejected due to financial reasons as the starting price of this evaluation kit is almost 600 USD.

### 2.3.2 Analog Evaluation Kit

Analog evaluation kit AS3435 from Austrian company AMS [1] was for a reasonable price, with full analog implementation. That means, the filtering can be only fixed (static) and filters are made of analog components such as resistors, capacitors etc.

Even though, in the end, the ANC will be a fully analog implementation, the evaluation board comes with Inter-Integrated Circuit (I2C), external AAA battery supply and software that provides infinite changes to configurations on a board. Power off resets the board to factory settings. Things that could be configured/adjusted are mainly:

1. microphone preamplifier gain
2. power control
3. monitor mode
4. mute settings for Microphones, headphones and line input.

Those settings could be saved in a software and reloaded anytime. After measurements and adjustments settings could be programmed to a single One Time Programmable cell (OTP) fuse. Programming the OTP fuse is a permanent change and the evaluation kit is able to do that three times. This comes in handy after completing the prototyping process so there is no need for a software or computer to be connected anymore. The software also provides a filter design tool where filters could be designed based on the measurements.

Software is supposed to generate a Bill Of Materials (BOM) after simulation for analog filters that have a dedicated space on the board separately for FF topology as well as FB topology.

Sadly, the documentation does not provide a manual for the software, which the manufacturer refers to as "user-friendly" with no warranty at all [1].

Choosing an evaluation kit simplifies many necessary steps that are crucial for making a functional prototype of ANC headset but may not be directly associated with the primary emphasis of the thesis which is an implementation of a method of noise cancellation. Those steps might include parts that provide functionality of the system, but should not affect the performance, like amplifiers, preamplifiers for microphones, connectors and so on that are built-in. Furthermore, it was necessary to study and understand the documentation of the evaluation kit with incomplete information for different functions of the kit as well as the software.

Optimizing every component, which should function smoothly and not disrupt measurements or complicate analog filter design, would be impractical. Development of a complete system from scratch will be left for future projects.

Following the assignment of this semestral thesis, a platform for ANC implementation - evaluation kit AS3435 from AMS. The AMS evaluation kit is shown in Figure 2.4.

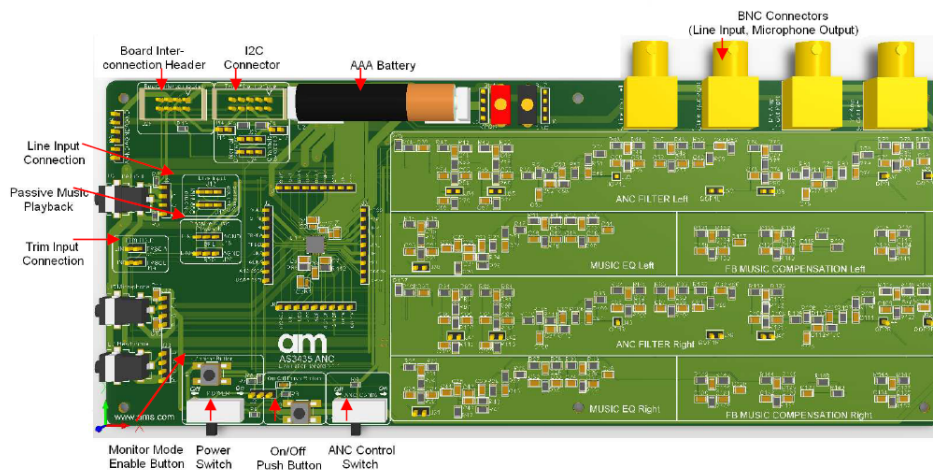

Fig. 2.4: AMS Evaluation Kit, taken from [1].

The analog filters have a dedicated space on the right side of the board. The complete data sheet of the evaluation kit is available in Electronic Appendix D or [1].

## 2.4 Filtering Algorithm

In Section 2.3, there was chosen an evaluation kit for the prototype, which practically determined the filtering algorithm. Although it could be interesting to get hands-on adaptive filtering, fixed filtering is a standard in the industry (Section 1.7) and therefore it should be more beneficial to work with this type of filtering, so it can be tuned to the way that it derives satisfactory results. Fixed filtering will utilize analog filters that will be designed based on the filter calculations (Section 3.3).

## 3 Practical Results

All of the fundamental measurements for ANC headphones design will be characterised in this chapter. Because there are two ANC topologies that work on very diverse principle: FF and FB, there is obviously a need to perform two different measurements. Hybrid topology is their combination, therefore the filter design does not require a separate measurement.

Measurements for a Feed-forward (FF) topology are much more complex and noise reduction performance is strongly dependent on them. They include frequency and phase response of the headset drivers and microphones as well as passive attenuation of the ear cups [2].

On the other hand, measurement for a Feedback (FB) topology is in fact quite simple. It includes just an open loop measurement between the headset driver and a FB microphone [13]. Filter for both ANC configurations is designed from gathering and combining all of the measured data which will be defined in Section 3.3.

### 3.1 Feed-forward Characterization

To characterize and design a filter for a FF ANC topology it is necessary to first look at different parameters that influence capturing the incoming noise. Firstly, there is an obvious passive barrier that will change the frequency spectrum of the incoming noise by the time it arrives in our ears. Simply capturing and inverting the noise will result in very poor performance, in the worst case in amplification of the incoming noise. Therefore, passive attenuation of the headphones has to be compensated and measured for the filter design [2].

Secondly, headsets drivers and ANC microphones are not ideal and they do not have flat frequency and phase response so they also need to be taken into account for the filter design.

All frequency and phase responses of measured components for FF ANC characterization are shown in Figures 3.1 and 3.2. In the following subsections will be evaluated in detail all performed measurements.

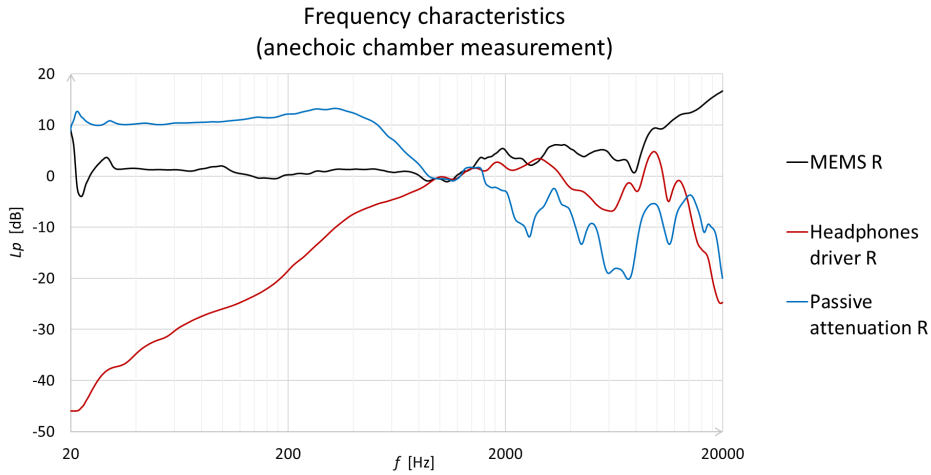

Fig. 3.1: Frequency response of the headset.

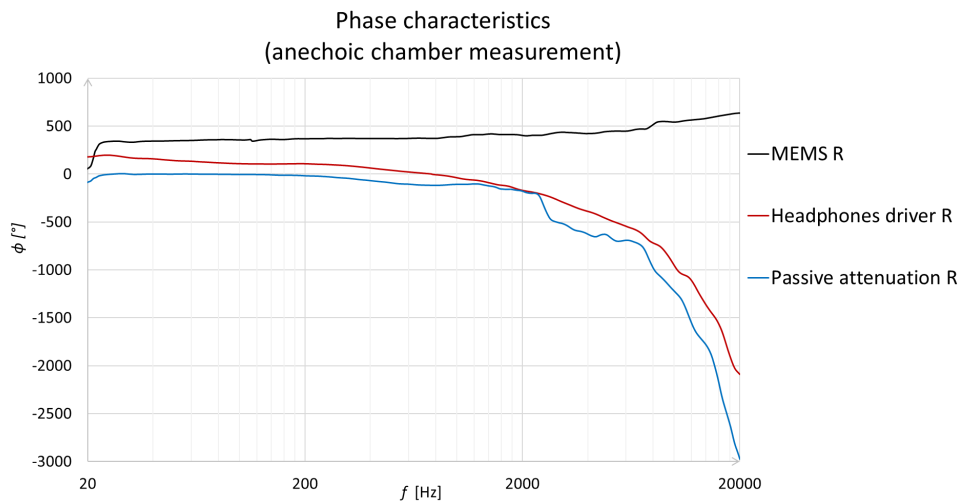

Fig. 3.2: Phase response of the headset.

### 3.1.1 Passive Attenuation

Passive attenuation measurement is quite straightforward and is performed in two simple steps.

- (a) The loudspeaker is placed on a stand, 1 m away, and the acoustic axis of the loudspeaker is identical to the acoustic axis of the input of the HATS ear canal. Sine sweep from 20Hz to 20kHz is played from any available audio measurement interface while the head is without the headset on.
- (b) Sine sweep is played again, now with the headset on [2].

Passive attenuation is later calculated directly in the software, APx500 by compare ratio

or in Excel as shown in Equation (3.1) where  $\Delta \text{dB(SPL)}$  is Passive attenuation, "with headphones dB(SPL)" is the second step in the measurement and "without headphones dB(SPL)" is the first step in the measurement.

$$\Delta \text{dB(SPL)} = \text{with headphones dB(SPL)} - \text{without headphones dB(SPL)} \quad (3.1)$$

The same applies to the phase response, so instead of dB values, degree values of the phase are being subtracted.

Figure 3.3 shows the actual measurement set-up and in Figure 3.4 is the block scheme of the measurement.

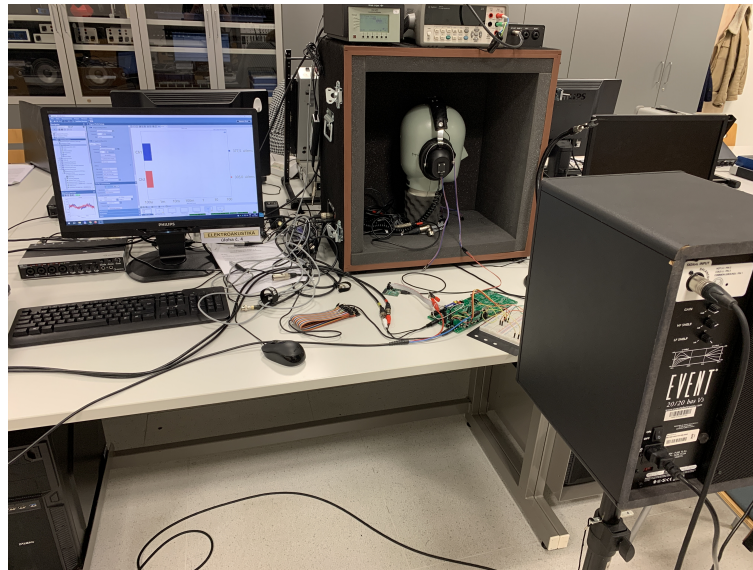

Fig. 3.3: In-box measurement.

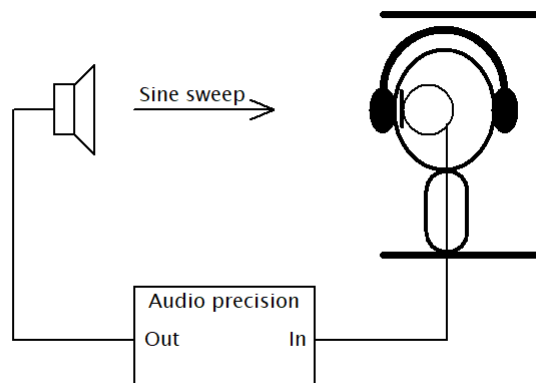

Fig. 3.4: Passive attenuation measurement block scheme, modified and taken from [2].

Equipment used in the measurement of the passive attenuation was: a studio monitor EVENT 20/20 bas V3, APx 525 audio analyzer and 1/2" 4189 free field microphone mounted in an ear of HATS (Head and torso simulator) type 4128c without a torso along with a charge amplifier 2692 Nexus, all from Brüel & Kjær.

The first measurement that has been performed was the passive attenuation of the headset. As was mentioned in Chapter 2, there were two available headphones to choose from. The goal for this measurement was to choose one headset based on its performance in passive attenuation. In Figure 3.5 is pretty obvious that the black headset does a much better job at noise reduction between 600 Hz and 4kHz.

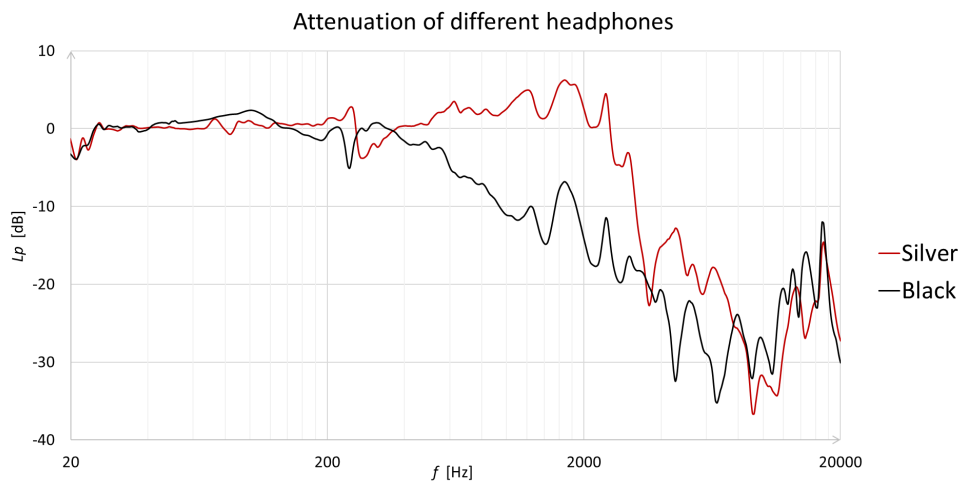

Fig. 3.5: Passive attenuation of two available headsets.

Although, passive noise cancelling is not crucial for a demonstration of a functional ANC, choosing the black headset over the silver will most likely mean much better final noise reduction. Frequency responses of both of the drivers were surprisingly very similar so it was not an important factor to consider while choosing a headset.

This first measurement was performed at the beginning when the headset did not have MEMS microphones mounted yet. As it is important to obtain the same measurement conditions, the measurement of the passive attenuation was repeated along with the frequency and phase response of the drivers and microphones. Sadly, it was found out that the box with the artificial head is causing resonance between 200 and 250 Hz as shown in the comparison between in-box measurement and anechoic chamber measurement (Figure 3.6).

Measurement had to be repeated in the anechoic chamber due to the fact that the resonance at lower frequencies would affect the filter design negatively.

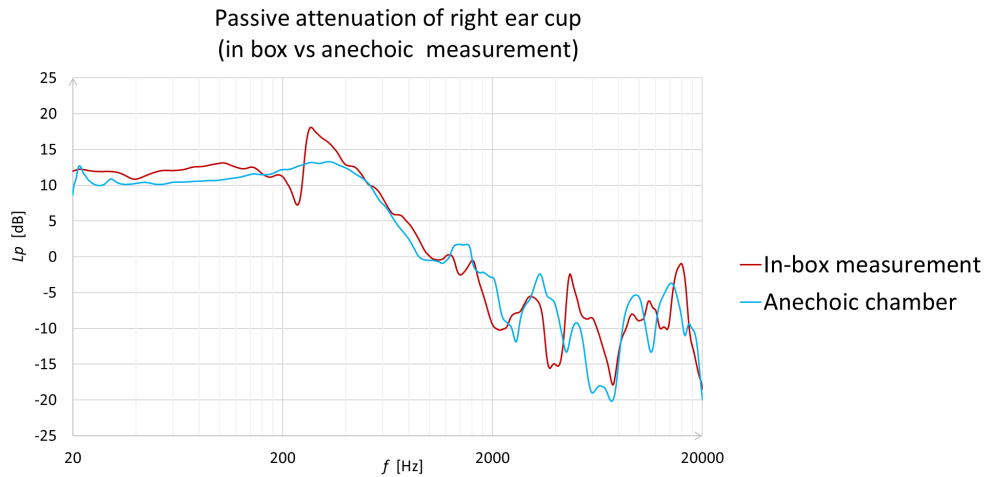

Fig. 3.6: Passive attenuation measurement comparison.

### 3.1.2 Drivers

The frequency and phase response of the drivers is a second fundamental measurement that is performed on the headset. The block scheme of this measurement is shown in Figure 3.7.

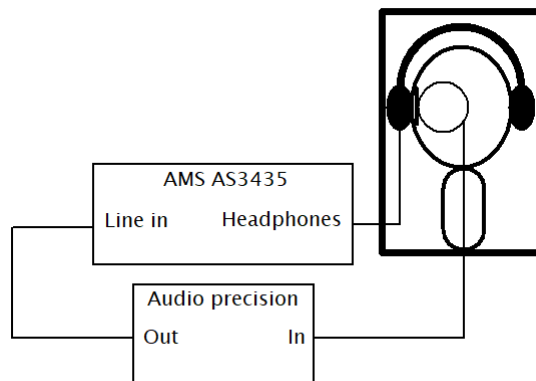

Fig. 3.7: Frequency and phase response of a driver block scheme, modified and taken from [2].

Sine sweep is played from the Audio precision through the evaluation kit, which should not affect the signal but has to be taken into account, to the headphones input and captured by the microphone in the head's ear [2]. Equipment used in this particular case was: APx 525 audio analyzer and 1/2" 4189 free field microphone mounted in an ear of HATS type 4128c without a torso along with a charge amplifier 2692 Nexus, all from Brüel & Kjær. Inbox measurement in this particular case had very little effect on the output data compared

to a measurement in the anechoic chamber as shown in Figure 3.8. The little differences in the low end and high end of the spectrum could be caused by the position of the headset on the head. Air leakages cause a drop in the low frequencies and the distance of the driver from the ear changes with the pressure of the headset when a headband is adjusted.

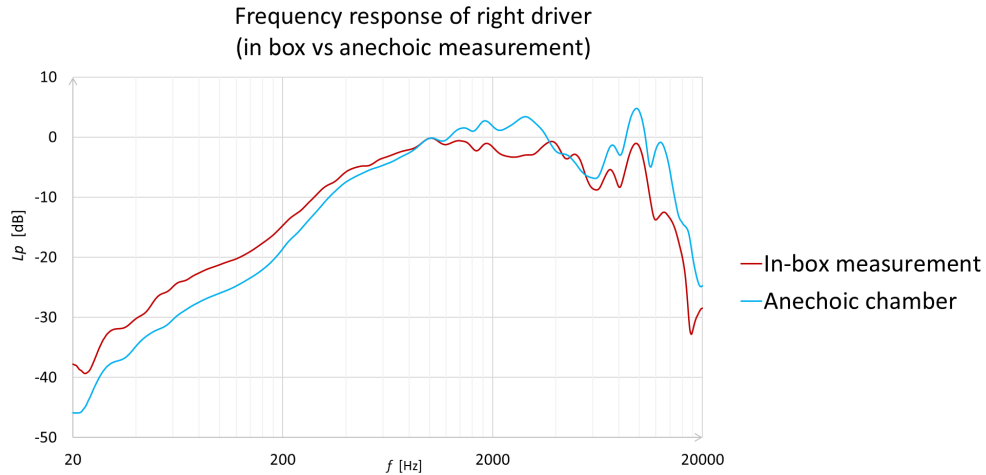

Fig. 3.8: Drivers measurement comparison.

### 3.1.3 Microphones

The third and last characterization measurement for a FF ANC is the frequency and phase characteristics of the MEMS microphones mounted on the outside of the ear cups. Figure 3.9 shows the block diagram of the measurement setup.

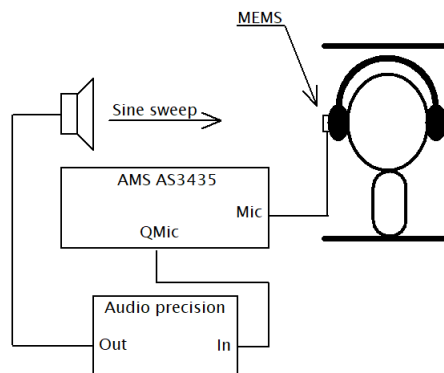

Fig. 3.9: Frequency and phase response of MEMS block scheme, modified and taken from [2].

Frequency and phase response of microphones is measured in two different ways [14]:

1. Simultaneous method - the voltage of a measured microphone and reference microphone is measured at the same time with a feedback generator that provides a constant voltage for a reference microphone. The advantage is that everything is done in one single measurement but reflections of wavelengths smaller than the size of the microphones could affect the measurement.
2. Substitutional method - the measured microphone and the reference microphone are measured at the same spot separately while a division of the output voltages of a reference microphone and measured microphone provides sensitivity of the measured microphone. The downside of this method is an uncertainty caused by not putting the microphones exactly in one spot.

The simultaneous method was performed during the in-box measurement while the substitutional method was used in the anechoic chamber. Although the results for frequency response from simultaneous measurements were satisfactory (reflections did not affect the measurements as much as was expected) as compared in the provided Figure 3.11, phase response for the reference microphone had a value of zero degrees across the whole spectrum. This result is practically impossible to obtain even though it is a high-quality reference microphone. Due to concerns of insufficient results had been concluded to repeat the measurement by a different method and in a quieter environment, hence the substitutional method in the anechoic chamber (see Figure 3.10) using the following measurement equipment: a studio monitor EVENT 20/20 bas V3, APx 525 audio analyzer and 1/2" 4189 free field microphone with a charge amplifier 2692 Nexus and HATS type 4128c without a torso, all from Brüel & Kjær.

## 3.2 Feedback Characterization

Feedback characterization measurement is rather simple compared to FF. There is required only one measurement: an open loop measurement between the headphone driver and the inner feedback microphone. Open loop measurement means to generate a sine sweep signal from 20 Hz to 20 kHz and to measure the frequency and phase response between the microphone and speaker and vice versa. It is performed by connecting the signal output of the Audio Precision APx 525 analyzer to the line input of the evaluation kit. The headphone driver must be connected to the headphone amplifier output on the board while the inner feedback microphone is connected to the preamplifier pin called "MIC". Signal input is taken from the "QMIC" pin on the board which is the output of the microphone preamplifier. The gain of the preamplifier is set to 0 dB and the headphone multiplexer is in the not connected position which is configured in the software for the evaluation kit [13]. The

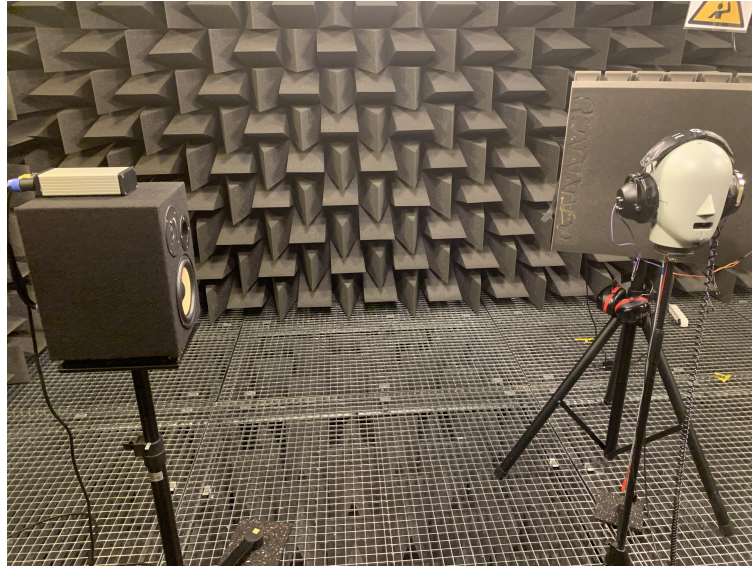

Fig. 3.10: FF ANC microphones measurement setup.

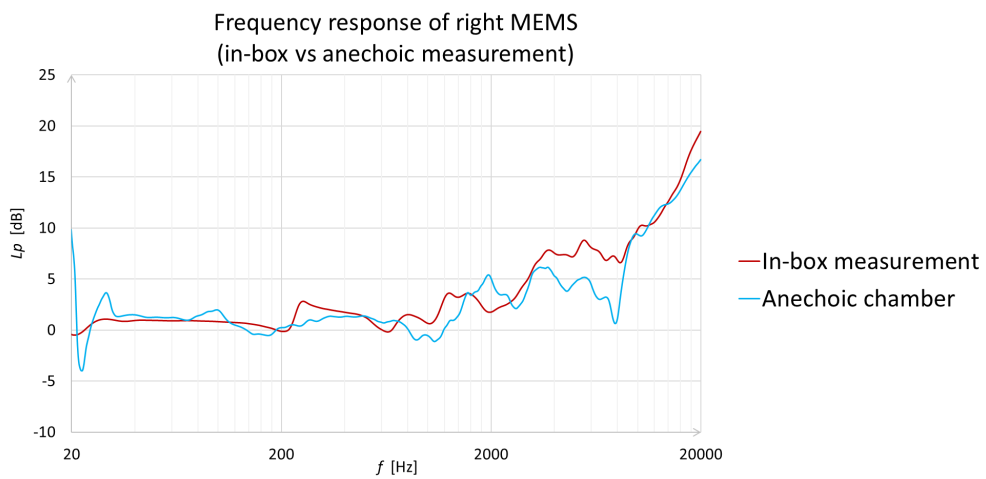

Fig. 3.11: Microphones measurement comparison.

block scheme of the open loop measurement setup is shown in Figure 3.12, HATS type 4128c without a torso is used only as a support for the headset.

In Figures 3.13 and 3.14 there are shown the frequency and phase response of the right side of the headset.

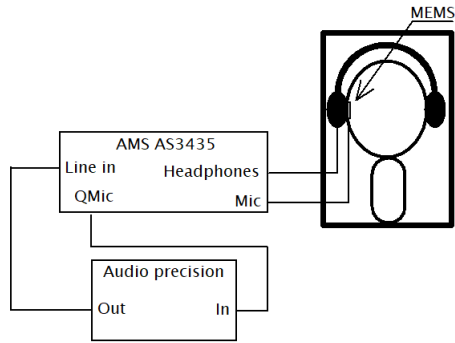

Fig. 3.12: Open loop measurement block scheme.

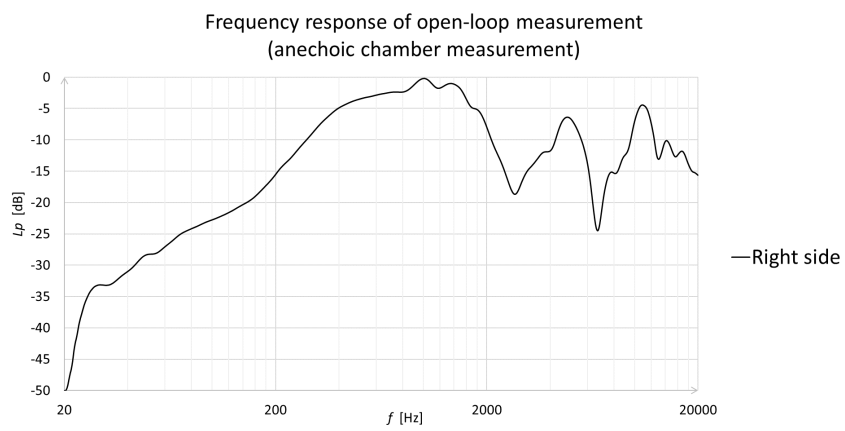

Fig. 3.13: Open loop measurement - frequency response.

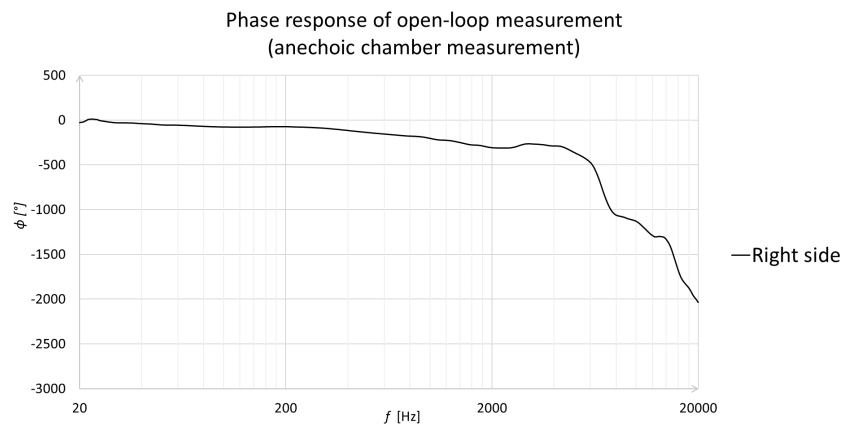

Fig. 3.14: Open loop measurement - phase response.

## 3.3 Filter Calculation

Filter calculation is the first step of a filter design. Filter design is mandatory for the ANC headset or any active noise reduction systems. Merely inverting the incoming signal is unlikely to yield satisfactory noise reduction results. Therefore, the ideal ANC filter gain and phase are calculated. Due to two different measurements there is a need to create separate filters for FF and FB ANC configuration. In the following subsections will be established the calculation for the ideal filters for both ANC topologies as well as the calculation of the filters based on the performed fundamental measurements.

### 3.3.1 Feed-forward Filter

Ideal ANC filter for the feed-forward topology according to [2] is calculated as follows:

- **Ideal FF Filter Gain**

$$A_{\text{filter}}(f) = A_1(f) - (A_2(f) + A_3(f)) \quad [\text{dB (SPL)}] \quad (3.2)$$

- **Ideal FF Filter Phase**

$$\phi_{\text{filter}}(f) = \phi_1(f) - (\phi_2(f) + \phi_3(f)) \quad [^\circ], \quad (3.3)$$

where  $A_{\text{filter}}(f)$  is the desired ideal filter gain in dB(SPL),  $A_1(f)$  is a gain of the passive attenuation,  $A_2(f)$  is the gain of the microphone response measurement and  $A_3(f)$  is the gain of the driver response measurement, all in dB(SPL).  $\phi_{\text{filter}}(f)$  is the desired ideal filter phase response in degrees,  $\phi_1(f)$  is a phase of the passive attenuation,  $\phi_2(f)$  is the phase of the microphone response measurement and  $\phi_3(f)$  is the phase of the driver response measurement, all in degrees.

Referring to the Equations (3.2) and (3.3) the gain and phase of the ANC filter for feed-forward topology were calculated based on the executed measurements (see Figures 3.15 and 3.16).

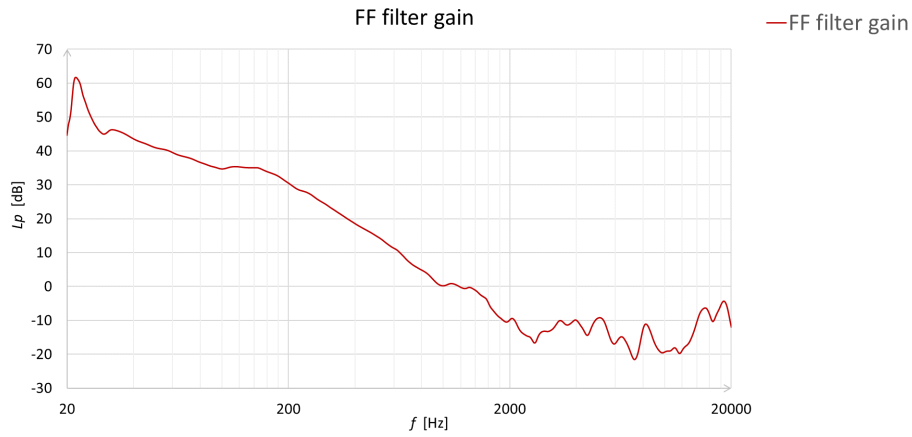

Fig. 3.15: FF filter gain calculation.

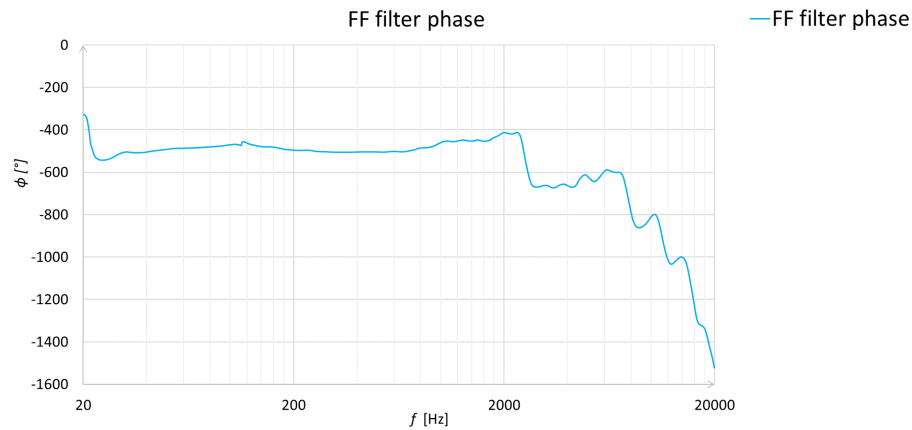

Fig. 3.16: FF filter phase calculation.

### 3.3.2 Feedback Filter

The calculation of the FB ANC filter is quite straightforward. Because there is only one measurement for the FB characterization, gain and phase response of the FB ANC filter are just an inversion of the measured characteristics [13]. Therefore, the amplitude of the filter is  $A_{filter}(f) = A_{measured}(f) * -1$ , where  $A_{filter}(f)$  is the desired ideal filter gain in dB(SPL),  $A_{measured}(f)$  is the frequency response of the open loop measurement in dB(SPL). Phase of the filter is  $\phi_{filter}(f) = \phi_{measured}(f) * -1$ , where  $\phi_{filter}(f)$  is the desired ideal filter phase response in degrees and  $\phi_{measured}(f)$  is the phase response of the open loop measurement. The calculated gain and phase of the FB ANC filter are shown in Figures 3.17 and 3.18.

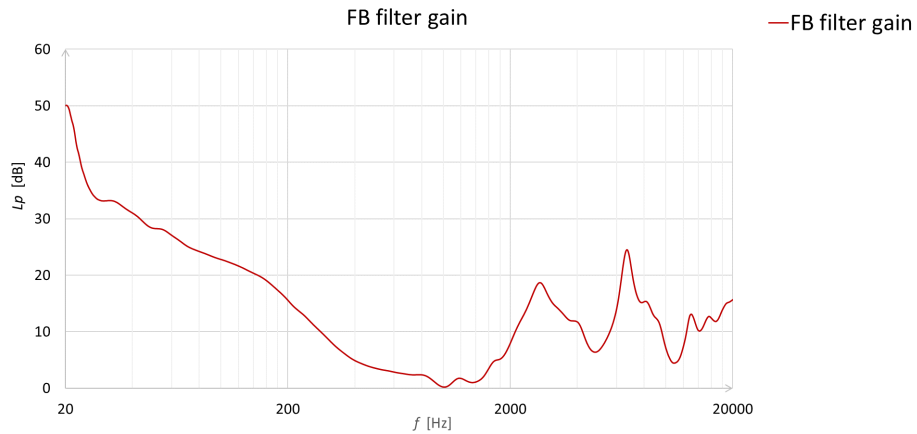

Fig. 3.17: FB filter gain calculation.

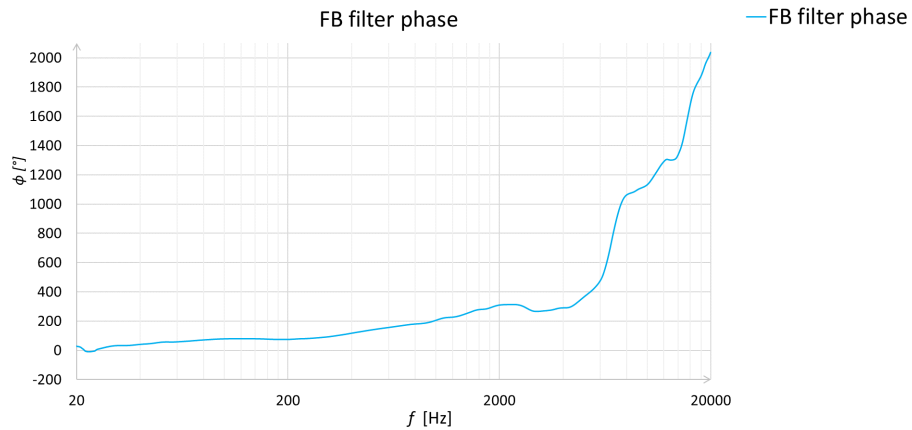

Fig. 3.18: FB filter phase calculation.

### 3.4 Filter Simulation

Filter simulation is the second step of the filter design process. The goal is to match the filter calculation results as close as possible in terms of the frequency and phase characteristics. The precision of matching the calculations will determine the results of a noise reduction. Analog filter implementation brings certain limits, however, keeping in mind that ANC does not reduce the noise above a certain threshold it is very much possible to build a filter that will copy the desired calculated filter.

Filter has been simulated in the AMS software provided with the board which is supposed to be based on the SPICE (Simulation Program with Integrated Circuit Emphasis).

The intuitive graphical user interface (GUI) makes the simulation process much easier as shown in Figure 3.19 but it also provides the option to choose specific components from the E24 series (in Figure 3.19 expert settings). Software analogically provides the same tool for the FB filter.

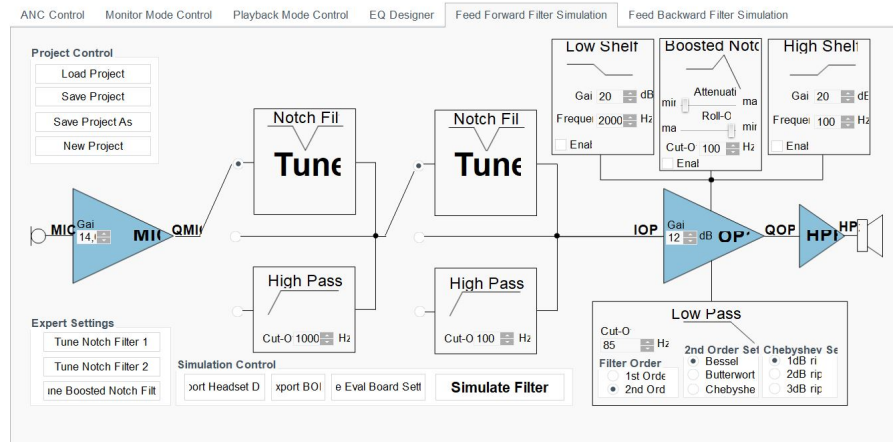

Fig. 3.19: FF filter simulation tool in AMS.

The result of the simulation of FF filter and its gain and phase response in AMS software is shown in Figure 3.20. The green curve (Measured) represents the calculation of the filter based on the headset measurement whereas the blue curve (Calculated) represents the simulation of the analog filter.

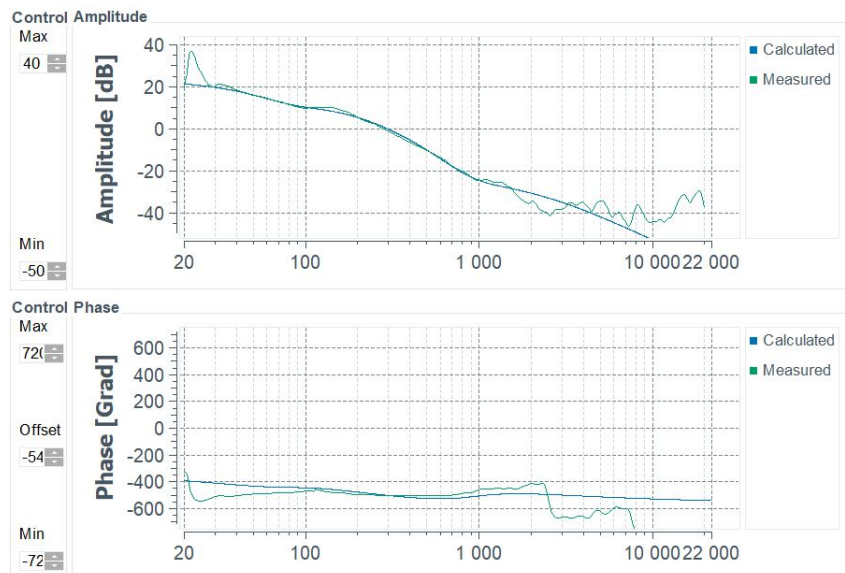

Fig. 3.20: FF filter simulation.

Figure 3.21 on the other hand shows the result of the simulation of FB filter and its gain and phase response in AMS software. The green curve is the calculation of the filter based on the headset measurement whereas the blue curve is the simulation of the analog filter.

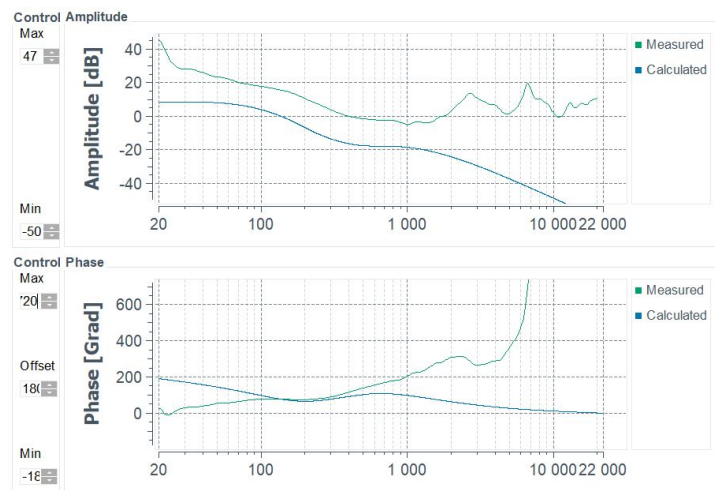

Fig. 3.21: FB filter simulation.

The gain mismatch of approximately 16 dB between the calculated and measured curves has been done on purpose due to the risk of an oscillation in the feedback system in the most important frequency region. The AMS software provides a warning tool based on the input data (shown in Figure 3.22) highlighting the frequency band with the red box where the oscillation is likely to occur. The microphone preamplifier is able to amplify the captured noise by 31 dB with a step of 0.5 dB, which could shift the curve up and match the filter calculation as closely as possible later in the noise reduction characterization measurement.

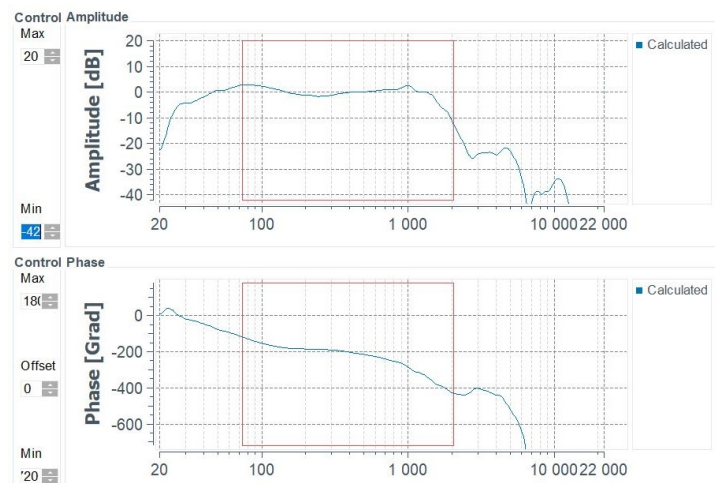

Fig. 3.22: FB oscillation warning tool.

### 3.5 Filter Soldering

Filter soldering is the next step after the filter simulation. All of the 0805 SMD capacitors and resistors from the E24 series had been placed and soldered to a dedicated space on the evaluation kit. Generated BOM is available in Appendix B. For this particular prototype, the FB ANC topology had been chosen for the left channel (see Figure 3.23) and the FF configuration for the right channel (see Figure 3.24). The schematic of analog filters for both right and left channels are available in Appendix C.

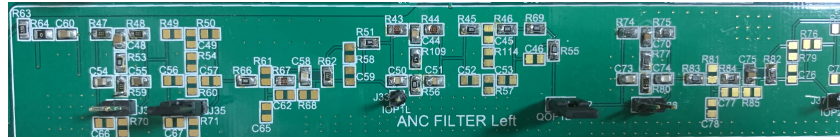

Fig. 3.23: FB analog filter.

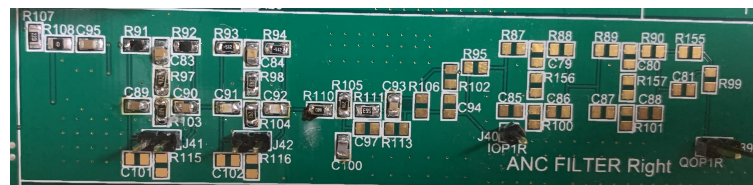

Fig. 3.24: FF analog filter.

### 3.6 Filter Evaluation

The last step of the filter design is the evaluation of the analog filters. After soldering the components it is necessary to make sure that all of them are secure in place and have electrical contact with the board. Evaluation also requires testing the frequency and phase response of the whole filter and checking for any errors or differences from the simulation. Measuring the frequency as well as phase response is fairly straight forward. For the FF filter (right channel on the evaluation board) output of the audio analyzer (in this case Audio Precision APx525 along with its software APx500) is connected to the MICR input, which is located at the input of the microphone preamplifier (schematic available in Appendix C), and analog ground pin on the board. The input of the analyzer is connected to the Headphones output pin and an analog ground pin. The same procedure applies to the FB filter (left channel on the evaluation board, MICL input). In the software, it is important to select the correct operational amplifier (OPAMP1 for FF and OPAMP2 for FB) and turn it on. The gain

on the microphone preamplifier is set to 0 dB. The results of the measurement, frequency and phase response of both of the filters, are shown in Figure 3.25.

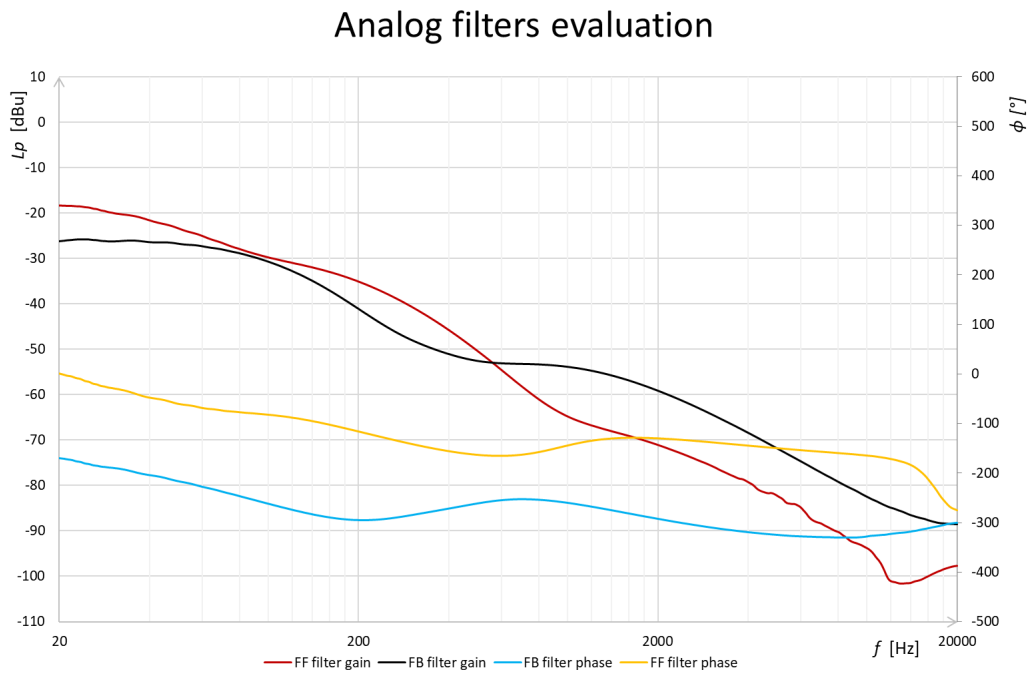

Fig. 3.25: Filters evaluation.

The AMS software does not provide the export of the simulations so the frequency and phase response could be compared only visually. FF filter (the red curve and blue curve) follows the shape of a simulated curve in frequency and phase response with a total attenuation of 70 dB (from 20 Hz to 10 kHz) whereas the simulation promises the same 70 dB attenuation up to 10 kHz. It means that the analog filter has been built correctly. Phase has also the same shape and values are all between -200 and -300 degrees which is in accordance with the simulation (exact values are determined by the input signal).

FB filter (black curve and yellow curve) also follows the shape of a simulated curve in both frequency and phase response. The filter's attenuation is 60 dB (from 20 Hz to 10 kHz) per the simulation. Filters for any ANC topologies should behave from a certain limit frequency as a low pass filter to cut of the higher frequencies that are not being actively cancelled by the ANC system.

## 3.7 Noise Cancelling Evaluation

The active noise-cancelling headset prototype based on the previous calculations, simulations and measurements using evaluation kit AS3435 from AMS will be evaluated in this section. The prototype uses only two out of three topologies: FF and FB since the evaluation board supports Hybrid topology only via the interconnection of two evaluation boards. The headset, however, has four microphones in total, so it is perfectly capable of using the Hybrid topology.

### 3.7.1 Evaluation Board Assessment

Before the actual ANC evaluation of the headset, it is necessary to ensure that the evaluation board is working properly. To do so, the following measurement setup is built: output number one of the audio analyzer (Audio Precision APx 525) is connected to the microphone input of the board as well as to the input number one of the APx via BNC-T connector. The headphone output of the evaluation board is connected to the second input of the APx. In simplest terms, the noise cancelling is being simulated by using only the board without the microphones or headphones, making the measurement faster and essentially more flexible since there is no need to use the anechoic chamber. Figure 3.26 shows the frequency and phase characteristic of the incoming test signal which is a sine sweep from APx (black curve, green curve) and the signal generated by the processor for the cancelling (red curve, blue curve). These results, however, do not represent the simulation of what will happen when the microphones and the headset are connected to the board. The red curve copies the FF analog filter. In this particular scenario, it is impossible to tell in advance how the system will behave as a whole because the filter has been designed to operate with the chosen headset and the microphones. It is merely a demonstration that the system is working.

While the evaluation board is working as expected most of the time, when running on an AAA battery, it sometimes causes software failure. The evaluation board is also not able to filter out the disrupting signals from the USB connection that occasionally interfere with the signals that are being processed on the board. The solution would be to use the OTP option (section 2.3.2), so the software is no longer needed. However, for the testing and measurements where several adjustments must be made, it is not the best option since the evaluation board could be fused only 3 times. Disrupting signals are shown in Figures 3.27. The board sometimes suddenly turned off the microphones so several measurements had been disrupted.

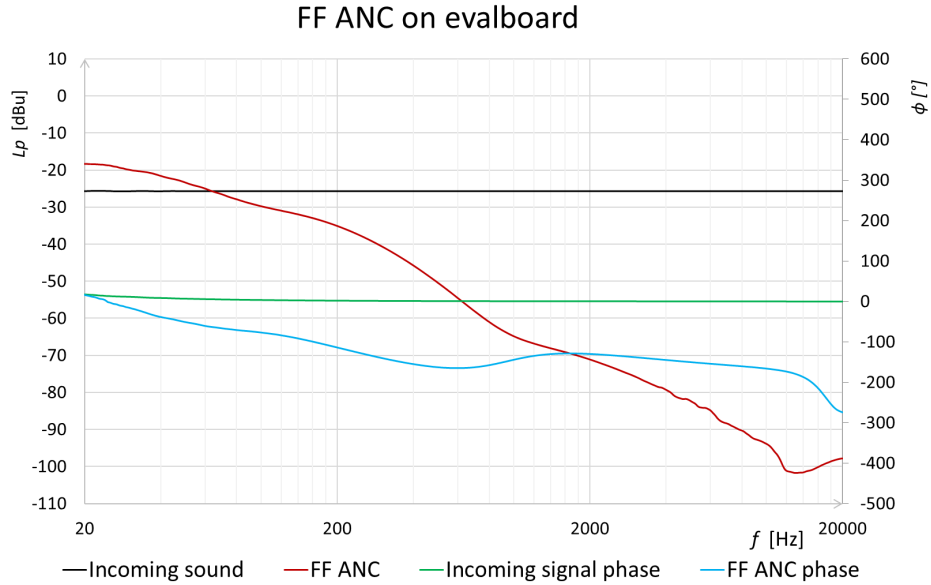

Fig. 3.26: Active Noise Cancelling on evaluation board.

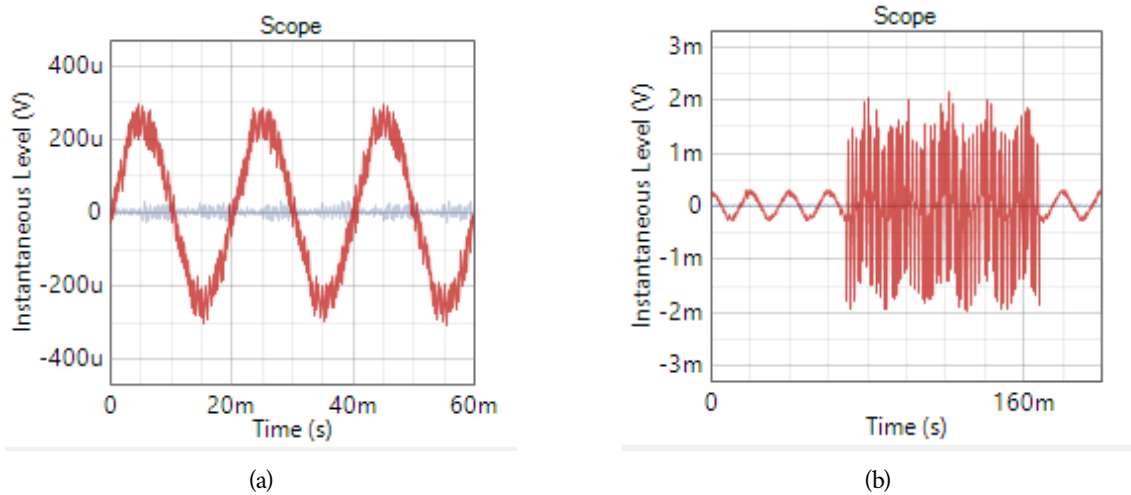

Fig. 3.27: (a) Occasional distortion of the output harmonic signal. (b) Occasional impulse appearing in the output signal.

The "perfect" noise cancelling is achieved in a monitor mode (shown in Figure 3.28) due to the inverting configuration of the microphone preamplifier. Monitor mode means that the microphone input bypasses the analog filters directly to the headphone output. In practice, this effect will be almost completely reduced by the microphones and the headset because they change the signal in gain and phase. The graph also shows very little effect on phase characteristics when turning up the volume, in this case by 10 dB (dashed lines) which has been configured in the AMS software as the gain of the microphone preamplifier.

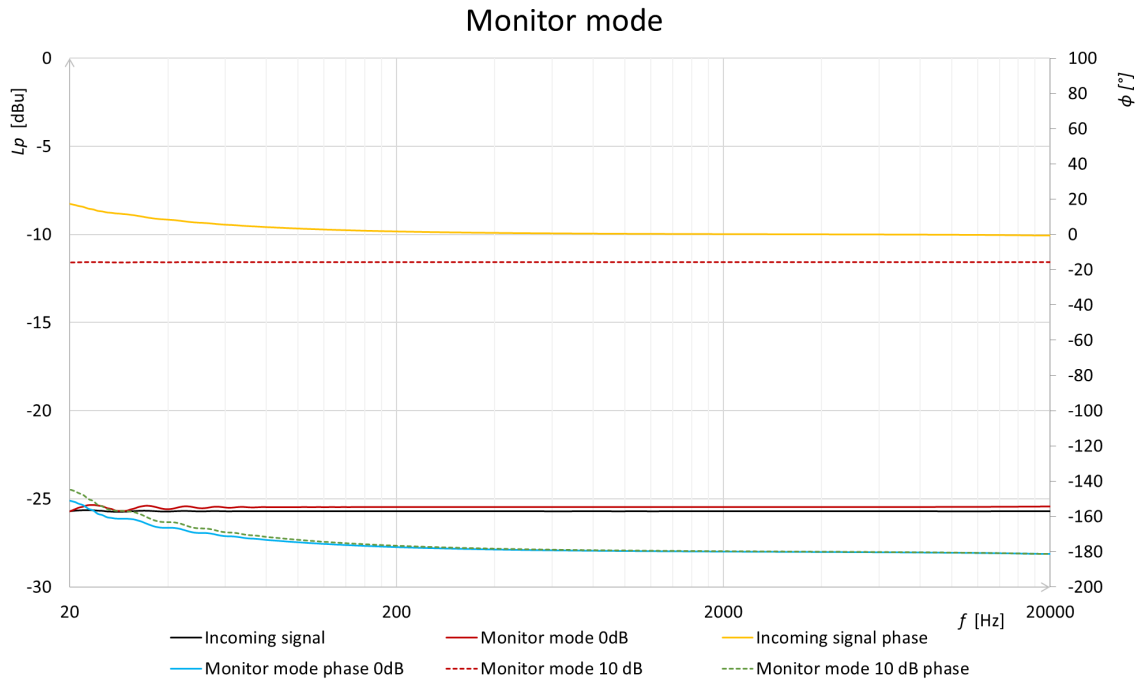

Fig. 3.28: Monitor on evaluation board

### 3.7.2 Active Noise Cancelling Evaluation

The last measurement of all is the ANC evaluation. The measurement is performed by placing the speaker (noise source) 50 cm away from the headset and on the axis with the outer microphone. The reference microphone in the artificial head is picking up the sound so the acoustic pressure can be measured inside of the ear cup with ANC on and off. For this particular measurement were used the following equipment: studio monitor EVENT 20/20 bas V3, APx 525 audio analyzer and 1/2" 4189 free field microphone with a charge amplifier 2692 Nexus and HATS type 4128c without a torso, all from Brüel & Kjær. Figure 3.29 shows the block scheme of the measurement setup.

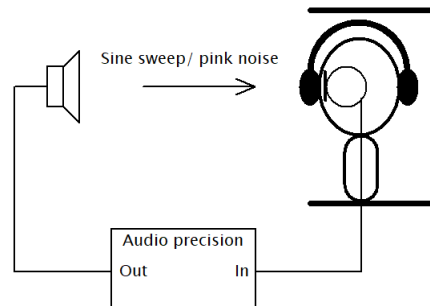

Fig. 3.29: ANC evaluation block scheme.

The first thing to evaluate before determining the effect of ANC is the effect of the PNC - Passive noise cancelling. In Figure 3.30 are displayed 3 different curves: the red curve is the acoustic pressure level in dB(SPL) of the noise source (sine sweep from 20 Hz to 20 kHz and 1.4 seconds long), the black curve is the PNC (headset is placed on the artificial head) and finally the blue curve is the ANC turned on. On this scale, the ANC effect is barely visible and the headset is apparently causing a resonance from 20 Hz up to 200 Hz that amplifies the incoming noise by almost 12 dB. The effect slowly decreases until around 800 Hz. Although, that much amplification, which is most likely the material origin (of the earcups) is not helpful at all, proper ANC design would eliminate it and also decrease the acoustic pressure level at the lower frequencies below the values of the red curve.

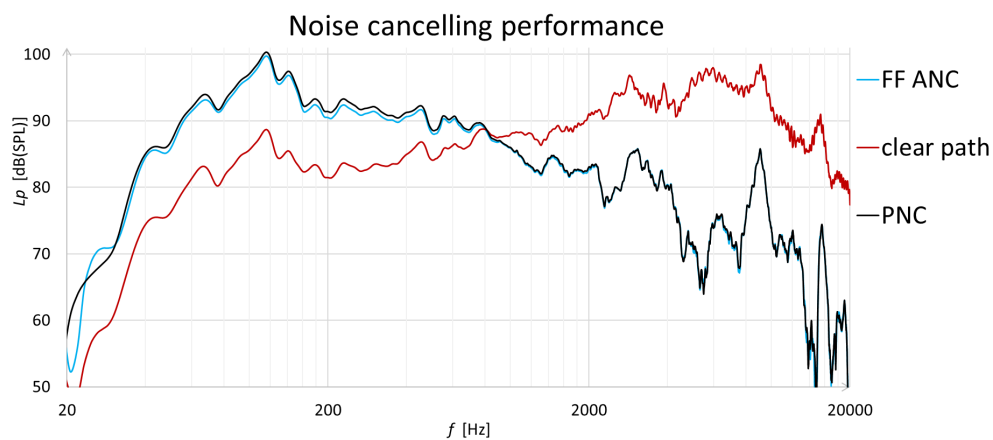

Fig. 3.30: PNC evaluation.

Unfortunately, this is not the case. Looking at Figures 3.31 and 3.32 where the acoustic pressure levels are displayed in dB(SPL) of PNC and ANC for both FF and FB topologies, is the noise reduction not sufficient. The actual effect of the ANC (difference of the acoustic pressure level of PNC and ANC) is calculated and displayed in Figure 3.33. The FF ANC configuration has the peak performance of 3.5 dB at around 130 Hz and frequencies from 250 to 350 Hz and 350-450 Hz are reduced by 1-2 dB. Frequencies from 30 Hz to 45 Hz are even amplified by 1-2 dB. Even though the measurement setup and technical equipment are precise, values under 1 dB could be taken as a measurement deviation. A subjective listening test showed that the ANC effect is not noticeable, which is pretty obvious from the measured data. FB ANC configuration has a slightly better overall performance with a reduction of 1-2 dB between 25-35 Hz, over 2 dB reduction between 60-100 Hz and a little over 1 dB between 300-500 Hz and at around 700 Hz. The FB ANC configuration caused, on the other hand, much more amplification compared to the FF ANC configuration, 3.5 dB at 25 Hz, 1.5 dB at 50 Hz and 200 Hz, 2 dB at 100 Hz and almost 2 dB at around 550 Hz.

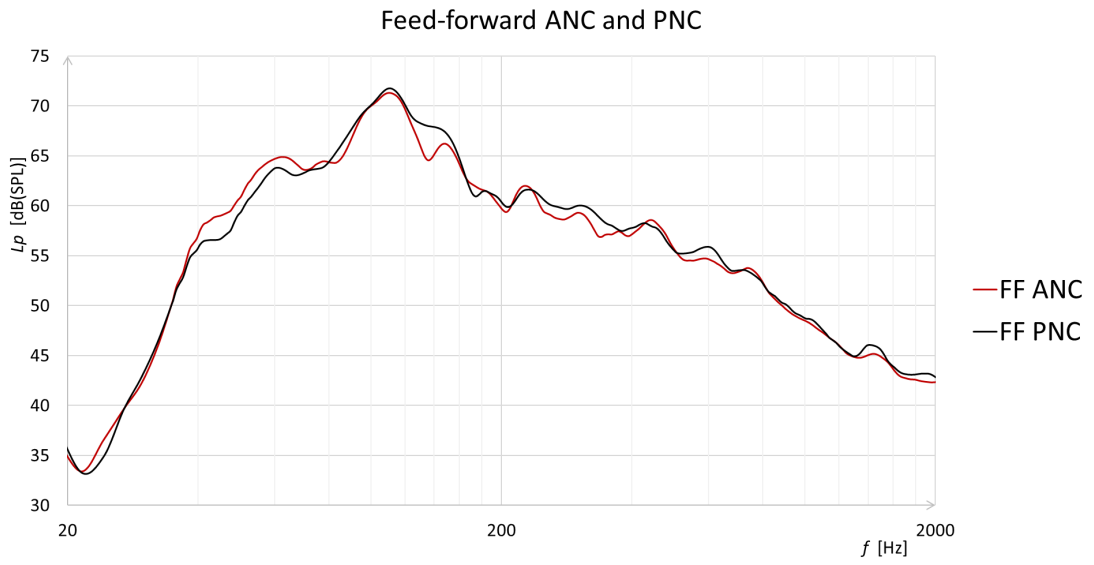

Fig. 3.31: FF ANC evaluation.

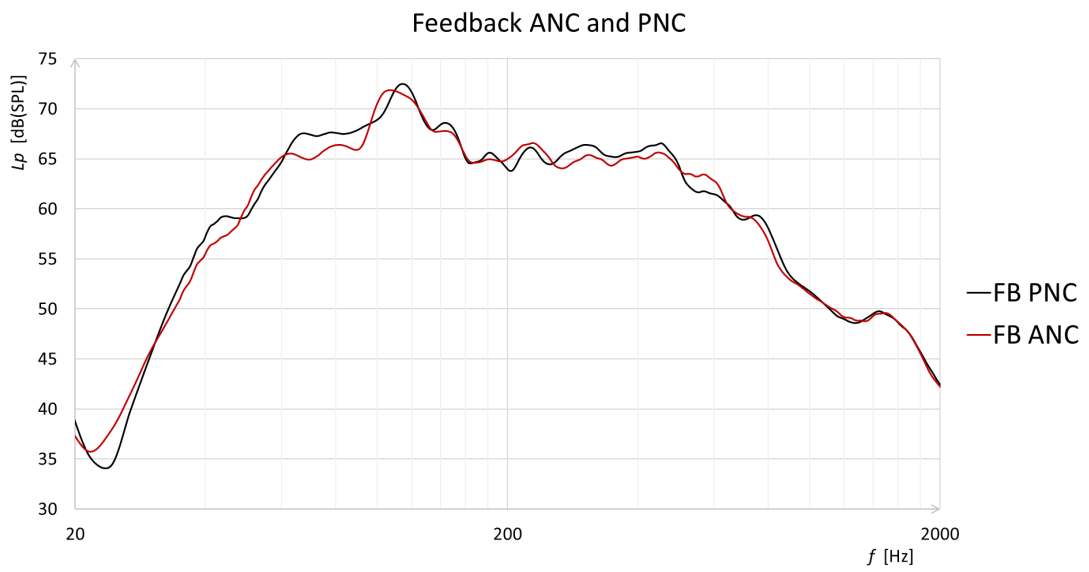

Fig. 3.32: FB ANC evaluation.

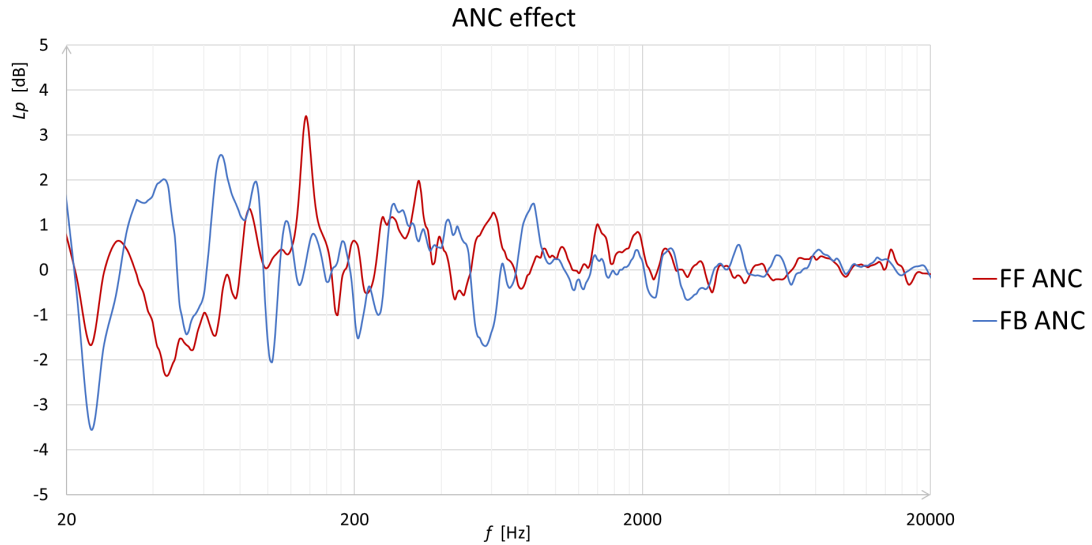

Fig. 3.33: Active noise reduction of FF and FB.

### 3.8 Comparison with other ANC headphones

The final ANC headset prototype has been also compared to two commercially available ANC headsets on the market (Figure 3.34): Bose QuietComfort 25 (red curve) and Sony WH-1000XM5 (black curve). The headset from Bose uses a FF topology (it has only 2 outer microphones) so it has a slightly better performance at the very low end. Sony, on the other hand, has 8 microphones in total, 2 are located inside and 6 outside. Hybrid topology of this kind has an astonishing noise reduction of over 20 dB from 60 Hz up to 400 Hz with a peak performance of more than 40 dB at roughly 300 Hz. It effectively cancels the noise from 30 Hz to almost 700 Hz. Despite the fact that the proposed ANC prototype for this thesis could not compete in performance with these two chosen ANC headsets, it demonstrates the noise reduction achievable in practice with proper acoustic and electronic design and how it improved over the years (the headset from Bose is a few years older than the headset from Sony).

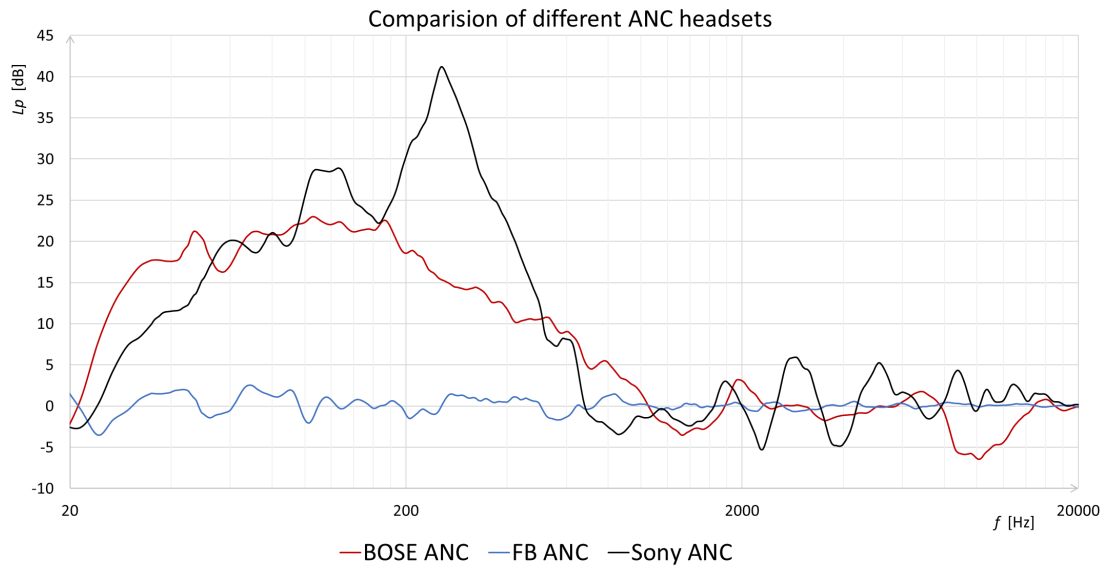

Fig. 3.34: ANC comparison.

# Conclusion

The main goal of this bachelor thesis was to propose a method of active noise cancelling for a headset and to build and measure a prototype of this kind.

Following the assignment of this bachelor thesis, different methods of active noise cancelling as well as three specific topologies of ANC headphones used in the industry were analyzed. Based on the essential parts of the ANC headset and their analysis a prototype was designed and built with four MEMS microphones. As it is crucial to measure the frequency and phase response of the headset to design a filter, there were performed various measurements.

In this particular project, different methods for measuring the frequency and phase response of all different components were used. Some of them turned out to be satisfactory and some of them had to be measured differently again. In the end, measurements were able to provide values for the filter calculation that were utilized later in the filter design. Designed analog filters were measured and compared to the simulations.

Chosen platform for this prototype was the analog evaluation kit AS3435 from the company AMS. Active noise cancelling was proposed to be implemented by the static filtering noise cancellation method with analog filters. This method was tested across two ANC topologies and compared to two commercially available solutions on the market.

Evaluation results despite countless measurements, investigations and analyses of the ANC headset prototype did not match the desired and expected active noise reduction. As there are potentially many reasons behind the not sufficient ANC performance, it is very important to analyze the whole prototyping process and to come up with solutions that could make the ANC headset better and well-functioning in the future. Firstly, analog solution has many advantages, it is indeed a cheaper option and does not require any AD/DA converters. Unfortunately, any changes to the frequency and phase response of the analog filter are not easily carried out. Digital filter, on the other hand, would be probably much flexible during the whole prototyping process. That is not to say that analog filters should be avoided at all costs, but it is simply more convenient to use the digital domain because the nowadays computing power allows that. Secondly, the material of the headset ear cups is causing an unusual resonance at the low frequencies, which most likely affected the measurements hence the final filter design and ANC/PNC performance. It appears that the acoustic design is indeed fundamental and should be taken into account much seriously for future projects. The chosen analog evaluation kit has also shown issues while running on battery or connected to the PC via USB which could potentially contribute to the level of the noise reduction.

The following solutions to improve the noise reduction of this particular prototype are recommended:

1. to repeat the measurements, design the filters again and compare the results,
2. to use another headset that has a better acoustical design,
3. to replace the analog platform with the digital platform so it could be tuned even at the end of the measurements much faster and easier.

# Bibliography

- [1] AMS AS3435 evalkit. Online, 2022, [cit. 2023-10-30]. Available from: <https://ams.com/as3435evalkit>
- [2] Gether, H.: *Design an ANC headset using the AS3415*. Online, [cit.2023-10-30]. Available from: <https://www.edn.com/design-an-anc-headset-using-the-as3415/>
- [3] Gether, H.: *Active noise cancellation: Trends, concepts, and technical challenges*. Online, [cit.2023-10-30]. Available from: <https://www.edn.com/active-noise-cancellation-trends-concepts-and-technical-challenges/>
- [4] Soundchip: *Active Noise Cancelling Headset Fundamentals*, 2013, white paper, Rue St Germain 8D Bussigny 1030, Switzerland.
- [5] Schimmel, J.: *Elektroakustika - Akustika uzavřených prostorů (prezentace)*, 2023.
- [6] Snyder, S. D.: *Active noise control primer*. New York: Springer, 2000, ISBN 03-879-8951-X.
- [7] Zachos, P.; Mourjopoulos, J. a.: Beamforming headphone ANC for targeted noise attenuation. In *Audio Engineering Society Convention 154*, May 2023, [cit.2024-5-25]. Available from: <https://www.aes.org/e-lib/browse.cfm?elib=22050>
- [8] Bruce, R.: *Comparing MEMS and Electret Condenser (ECM) Microphones*. Online, [cit.2023-11-27]. Available from: <https://www.cuidevices.com/blog/comparing-mems-and-electret-condenser-microphones>
- [9] STMicroelectronics: *MEMS Microphones: Top Or Bottom?* Online, 2022, [cit.2023-11-27]. Available from: <https://www.youtube.com/watch?app=desktop&v=PwgxLOG79zk>
- [10] Mannion, P.: *Teardown: Analog rules over digital in noise-canceling headphones*. Online, [cit.2023-11-29]. Available from: <https://www.edn.com/teardown-analog-rules-over-digital-in-noise-canceling-headphones/>
- [11] Hänslér, E.; Schmidt, G.: *Acoustic echo and noise control*. Hoboken: John Wiley, 2004, ISBN 04-714-5346-3.
- [12] Yin, L.; Zhang, Z.; Wu, M.; aj.: Selective fixed-filter active noise control based on frequency response matching in headphones. *Applied Acoustics*, ročník 211, 2023: str. 109505, ISSN 0003-682X, doi:<https://doi.org/10.1016/j.apacoust.2023.109505>. Available from: <https://www.sciencedirect.com/science/article/pii/S0003682X23003031>

- [13] Gether, H.: *Designing a feedback ANC headset using AS3435*. Online, [cit.2023-10-30]. Available from: <https://www.edn.com/designing-a-feedback-anc-headset-using-as3435/>
- [14] Schimmel, J.: *Elektroakustika - Mikrofony (prezentace)*, 2023.
- [15] Bruce, R.: *Analog or Digital: How to Choose the Right MEMS Microphone Interface*. Online, [cit.2023-11-27]. Available from: <https://www.cuidevices.com/blog/analog-or-digital-how-to-choose-the-right-mems-microphone-interface>
- [16] Mouser. 2023, [cit.2023-12-4]. Available from: [https://cz.mouser.com/datasheet/2/670/cmm\\_2718ab\\_38162w\\_tr-3159469.pdf](https://cz.mouser.com/datasheet/2/670/cmm_2718ab_38162w_tr-3159469.pdf)
- [17] *EVAL-ADAU1787Z*. Online, [cit.2023-12-6]. Available from: <https://www.analog.com/en/design-center/evaluation-hardware-and-software/evaluation-boards-kits/eval-adau1787z.html#eb-overview>

# Symbols and abbreviations

| <b>Abbreviation</b> | <b>Meaning</b>                                      |  |
|---------------------|---|--|
| FF                  | Feed-forward ANC topology                           |  |
| FB                  | Feedback ANC topology                               |  |
| ANC                 | Active noise cancelling                             |  |
| ASIC                | Application-Specific Integrated Circuit             |  |
| ADC                 | analog-to-digital converter                         |  |
| JFET                | junction field-effect transistor                    |  |
| SNR                 | Signal-to-noise ratio                               |  |
| PCB                 | Printed Circuit Board                               |  |
| ECM                 | Electret condenser microphone                       |  |
| A/D                 | Analog to Digital                                   |  |
| D/A                 | Digital to Analog                                   |  |
| DSP                 | Digital signal processor                            |  |
| MEMS                | Micro-Electro-Mechanical System                     |  |
| SDK                 | Software development kit                            |  |
| BOM                 | Bill of Materials                                   |  |
| OTP                 | One Time Programmable                               |  |
| SPICE               | Simulation Program with Integrated Circuit Emphasis |  |
| GUI                 | graphical user interface                            |  |
| HATS                | Head and Torso Simulator                            |  |
| SMD                 | Surface-mount device                                |  |
| PNC                 | Passive noise cancelling                            |  |

| <b>Symbol</b> | <b>Dimension</b>       | <b>Quantity</b>  |
|---------------|------------------------|--|
| $f$           | [Hz]                   | frequency  |
| $c_0$         | [m · s <sup>-1</sup> ] | speed of sound in air at 20 °C                                 |
| $\lambda$     | [m]                    | wavelength of a sound wave                                     |
| $\varphi$     | [°]                    | phase  |
| $L_p$         | [dB]                   | sound pressure level   |
| $L_p$         | [dB(SPL)]              | sound pressure level with reference to $p_0 = 20 \mu\text{Pa}$ |

# List of appendices

|          |   |           |
|----------|---|-----------|
| <b>A</b> | <b>Datasheet of MEMS microphone</b>       | <b>60</b> |
| <b>B</b> | <b>BOM for analog filters</b>             | <b>63</b> |
| <b>C</b> | <b>Schematic of AS3435 evaluation kit</b> | <b>64</b> |
| <b>D</b> | <b>Contents of Electronic Appendix</b>    | <b>72</b> |

# A Datasheet of MEMS microphone

Additional Resources: [Product Page](#)



date 04/06/2023

page 1 of 6

**MODEL:** CMM-2718AB-38162W-TR | **DESCRIPTION:** MEMS MICROPHONE

## FEATURES

- bottom port
- analog
- omnidirectional
- frequency response range (20 Hz-20 kHz)

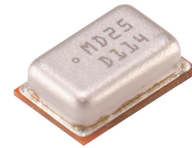

## ELECTRICAL

| parameter                              | conditions/description                                  | min | typ  | max    | units  |
|--|---|-----|------|--------|--------|
| directivity                            | omnidirectional   |     |      |        |        |
| sensitivity (S)                        | at 1 V/Pa, 1 kHz  | -39 | -38  | -37    | dB     |
| supply voltage (V <sub>DD</sub> )      |   | 1.5 |      | 3.6    | V      |
| current consumption (I <sub>DD</sub> ) |   |     | 150  | 170    | μA     |
| sensitivity reduction                  | no change across the voltage range                      |     |      |        | dB     |
| frequency (f)                          |   | 20  |      | 20,000 | Hz     |
| signal to noise ratio (S/N)            | 20 kHz bandwidth, A-weighted                            |     | 62   |        | dB(A)  |
| total harmonic distortion (THD)        | at 94 dB SPL, 1 kHz, R <sub>load</sub> > 2 k            |     | 0.1  |        | %      |
| acoustic overload point (AOP)          | at 10% THD, 1 kHz, R <sub>load</sub> > 2 k              |     | 123  |        | dB SPL |
| output impedance (Z <sub>out</sub> )   | at 1 kHz  |     | 200  |        | Ω      |
| dc output                              |   |     | 0.7  |        | V      |
| PSRR                                   | 200 mVp-p sine wave @ 1 kHz, V <sub>DD</sub> = 1.8 V    |     | 70   |        | dB     |
| PSR                                    | 100 mVp-p square wave @ 217 Hz, V <sub>DD</sub> = 1.8 V |     | -100 |        | dBV(A) |

Notes: 1. All specifications measured at 25°C, humidity at 45±5%, unless otherwise noted.

## ENVIRONMENTAL

| parameter             | conditions/description | min | typ | max | units |
|-----------------------|------------------------|-----|-----|-----|-------|
| operating temperature |                        | -20 |     | 70  | °C    |
| storage temperature   | in packaging           | -40 |     | 100 | °C    |
| RoHS                  | yes                    |     |     |     |       |

## MECHANICAL

| parameter     | conditions/description | min | typ  | max | units |
|---------------|------------------------|-----|------|-----|-------|
| dimensions    | 2.75 x 1.85 x 0.90     |     |      |     | mm    |
| acoustic port | bottom                 |     |      |     |       |
| terminals     | surface mount          |     |      |     |       |
| weight        |                        |     | 0.03 |     | g     |

cuidevices.com

## MECHANICAL DRAWING

units: mm  
 tolerance:  
 length, width, height:  $\pm 0.10$  mm  
 acoustic port:  $\pm 0.05$  mm  
 unless otherwise specified:  $\pm 0.15$  mm

| TERMINAL CONNECTIONS |          |
|----------------------|----------|
| TERM.                | FUNCTION |
| 1                    | VDD      |
| 2                    | output   |
| 3                    | GND      |

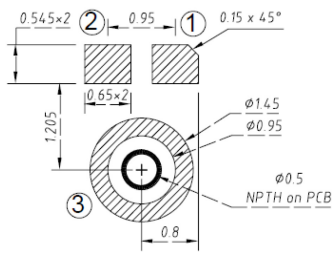
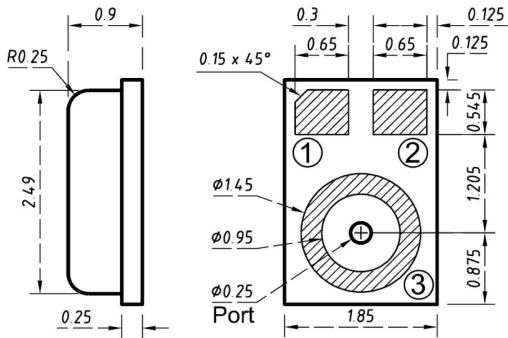
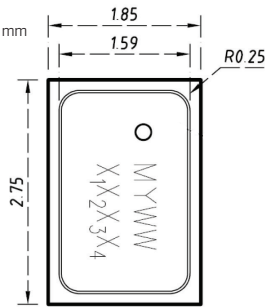

Recommended PCB Layout  
Top View

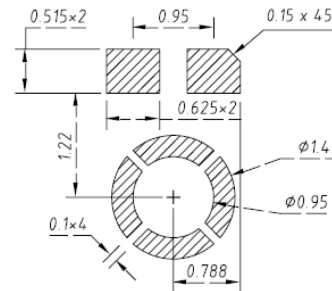

Recommended Stencil Layout  
Top View

## INTERFACE CIRCUIT

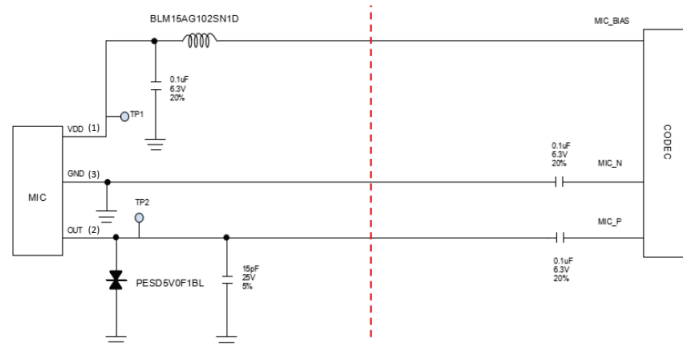

Note: 2. It is recommended that the components on the left side of red line be placed close to MIC, and components on the right side of red line be placed close to CODEC.

## FREQUENCY RESPONSE CURVE

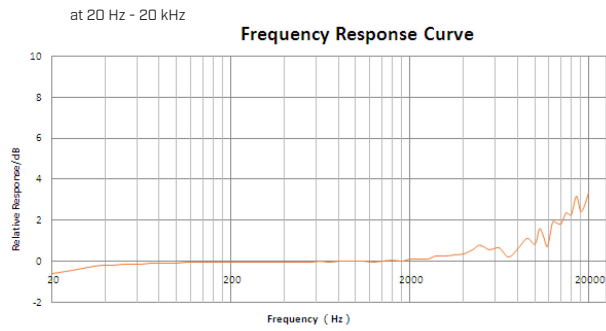
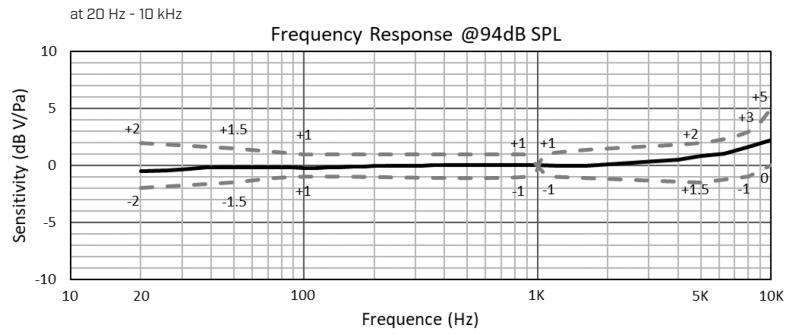

## PHASE

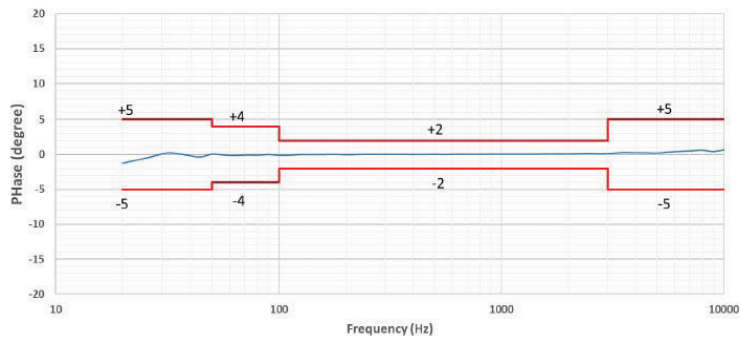

|     | 20-50 Hz | 50-100 Hz | 100 Hz-3 kHz | 3-10 kHz |
|-----|----------|-----------|--------------|----------|
| Max | +5°      | +4°       | +2°          | +5°      |
| Min | -5°      | -4°       | -2°          | -5°      |

## B BOM for analog filters

| FF BOM       |                                       |
|--------------|---------------------------------------|
| Component    | Value                                 |
| R86          | 47.50k                                |
| R112         | 47.50k                                |
| C7           | 10.00u                                |
| C6           | 10.00u                                |
| C60          | 2.20u                                 |
| C95          | 2.20u                                 |
| R47          | 1k                                    |
| R91          | 1k                                    |
| R48          | 1k                                    |
| R92          | 1k                                    |
| R59          | 510 (zmenene na 680)                  |
| R103         | 510                                   |
| R53          | 4.30k                                 |
| R97          | 4.30k                                 |
| C54          | 1.60u                                 |
| C89          | 1.60u (zmenene na 1.5u kvoli obchodu) |
| C55          | 1.60u                                 |
| C90          | 1.60u                                 |
| C48          | 3.30u                                 |
| C83          | 3.30u                                 |
| J34          | Open                                  |
| J41          | Open                                  |
| R49          | 5.10k                                 |
| R93          | 5.10k                                 |
| R50          | 5.10k                                 |
| R94          | 5.10k                                 |
| R60          | 2.40k                                 |
| R104         | 2.40k                                 |
| R54          | 24k                                   |
| R98          | 24k                                   |
| C56          | 33.00n                                |
| C91          | 33.00n                                |
| C57          | 33.00n                                |
| C92          | 33.00n                                |
| C49          | 62.00n (68n kvoli obchodu)            |
| C84          | 62.00n                                |
| J35          | Open                                  |
| J42          | Open                                  |
| R66          | 68k                                   |
| R110         | 68k                                   |
| R61          | 270k                                  |
| R105         | 270k                                  |
| R67          | 56k                                   |
| R111         | 56k                                   |
| C58          | 4.70n                                 |
| C93          | 4.70n                                 |
| C65          | 30.00n                                |
| CunknownLow2 | 30.00n                                |

| FB BOM    |         |
|-----------|---------|
| Component | Value   |
| R64       | 0.00    |
| R108      | 0.00    |
| R86       | 22k     |
| R112      | 22k     |
| C7        | 10.00u  |
| C6        | 10.00u  |
| C60       | 750.00n |
| C95       | 750.00n |
| J35       | Set     |
| J42       | Set     |
| R47       | 2.20k   |
| R91       | 2.20k   |
| R48       | 2.20k   |
| R92       | 2.20k   |
| R59       | 1.10k   |
| R103      | 1.10k   |
| R53       | 18k     |
| R97       | 18k     |
| C54       | 270.00n |
| C89       | 270.00n |
| C55       | 270.00n |
| C90       | 270.00n |
| C48       | 470.00n |
| C83       | 470.00n |
| J34       | Open    |
| J41       | Open    |
| R43       | 20k     |
| R87       | 20k     |
| R44       | 20k     |
| R88       | 20k     |
| R56       | 10k     |
| R100      | 10k     |
| R109      | 1.00    |
| R156      | 1.00    |
| R67       | 20k     |
| R111      | 20k     |
| R62       | 39k     |
| R106      | 39k     |
| R66       | 0.00    |
| R110      | 0.00    |
| R51       | 160k    |
| R95       | 160k    |
| R45       | 0.00    |
| R89       | 0.00    |
| R46       | 0.00    |
| R90       | 0.00    |
| R69       | 0.00    |
| R155      | 0.00    |
| R55       | 0.00    |
| R99       | 0.00    |
| C50       | 82.00n  |
| C85       | 82.00n  |
| C51       | 82.00n  |
| C86       | 82.00n  |
| C44       | 180.00n |
| C79       | 180.00n |
| C58       | 27.00n  |
| C93       | 27.00n  |
| R74       | 2.20k   |
| R119      | 2.20k   |
| R75       | 2.20k   |
| R120      | 2.20k   |
| R80       | 1.10k   |
| R125      | 1.10k   |
| R77       | 39k     |
| R122      | 39k     |
| C73       | 150.00n |
| C108      | 150.00n |
| C74       | 150.00n |
| C109      | 150.00n |
| C70       | 330.00n |
| C105      | 330.00n |
| J38       | Open    |
| J45       | Open    |
| R84       | 4.70k   |
| R129      | 4.70k   |
| R82       | 6.80k   |
| R127      | 6.80k   |
| R83       | 0.00    |
| R128      | 0.00    |
| C75       | 82.00n  |
| C110      | 82.00n  |

## C Schematic of AS3435 evaluation kit

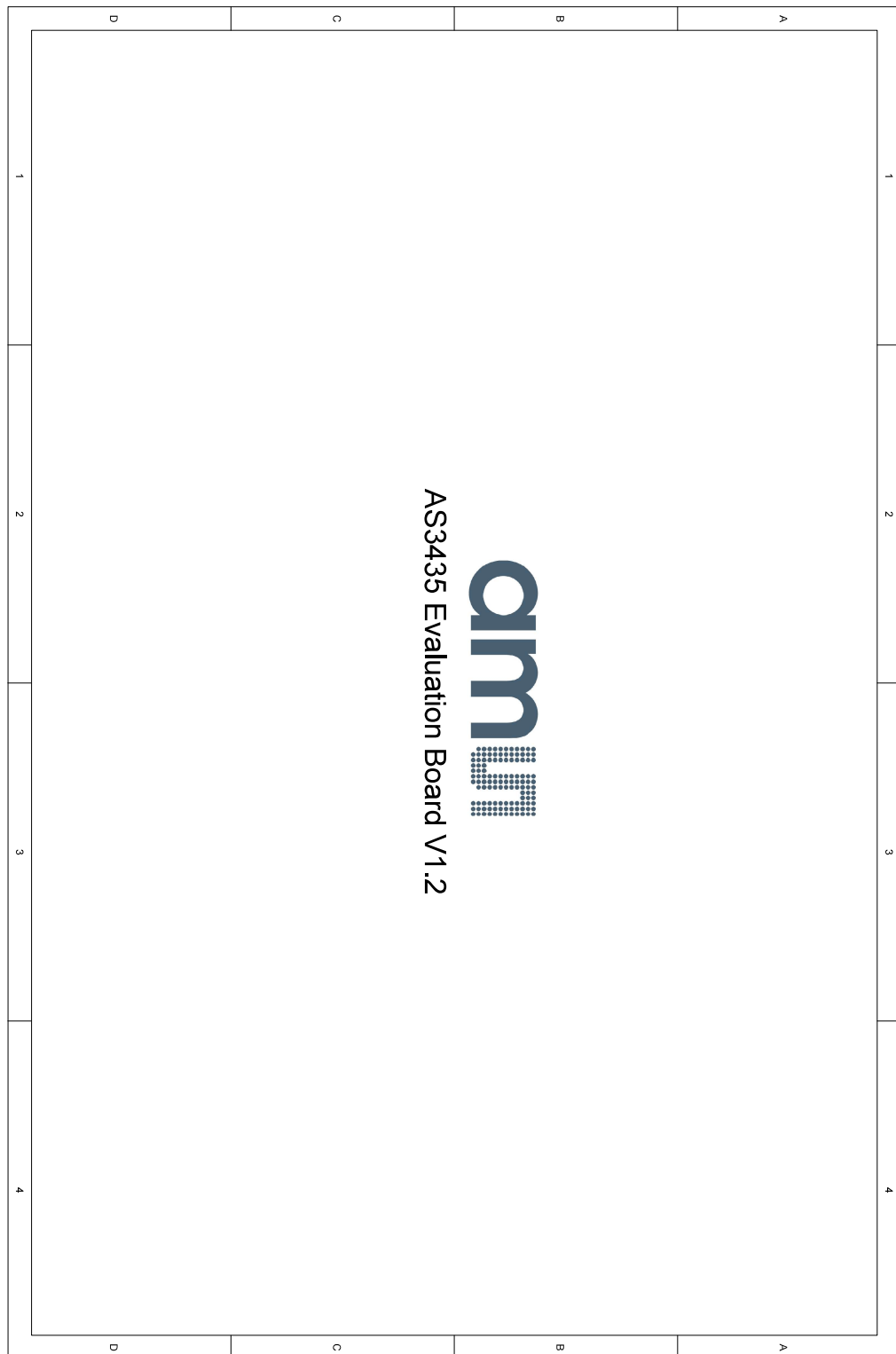

# AS3435 Evaluation Board V1.1



## Table of Contents

|  |
|--|
| Sheet 1: Title Page                    |
| Sheet 2: Project Page (This page)      |
| Sheet 3: AS3435                        |
| Sheet 4: Audio Connectors              |
| Sheet 5: Music EQ                      |
| Sheet 6: ANC Filter Right              |
| Sheet 7: ANC Filter Left               |
| Sheet 8: FB Music Compensation Network |

## Revision History

|       |  |
|-------|--|
| V1.0: | Released on 12/05/12                         |
| V1.1: | Released on 01/02/13                         |
|       | -Added FB notch filter resistors             |
|       | -Added second notch filter @ Music EQ        |
| V1.2: | Released on 05/28/13                         |
|       | -Added BSS94 transistor circuit for Mode pin |
|       | -Removed J16, J17                            |

## PCB Stackup

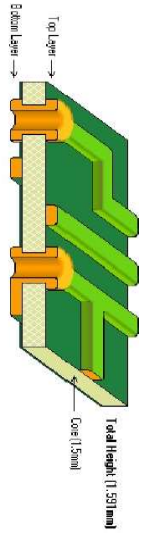

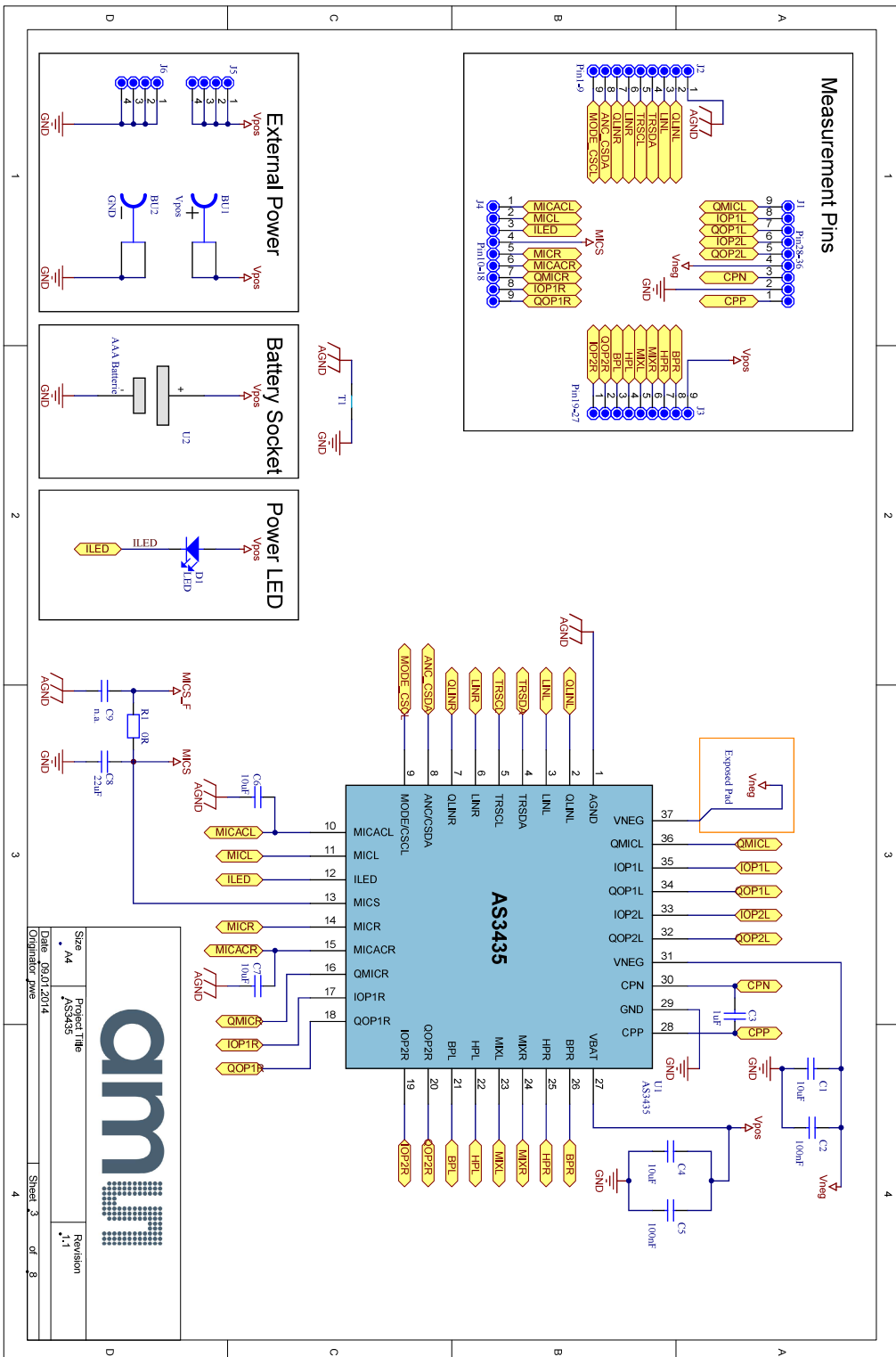





|            |            |               |        |
|------------|------------|---------------|--------|
| Size       | A4         | Project Title | AS3435 |
| Date       | 06.01.2014 | Revision      | 1.1    |
| Originator | pwe        | Sheet         | 3 of 8 |

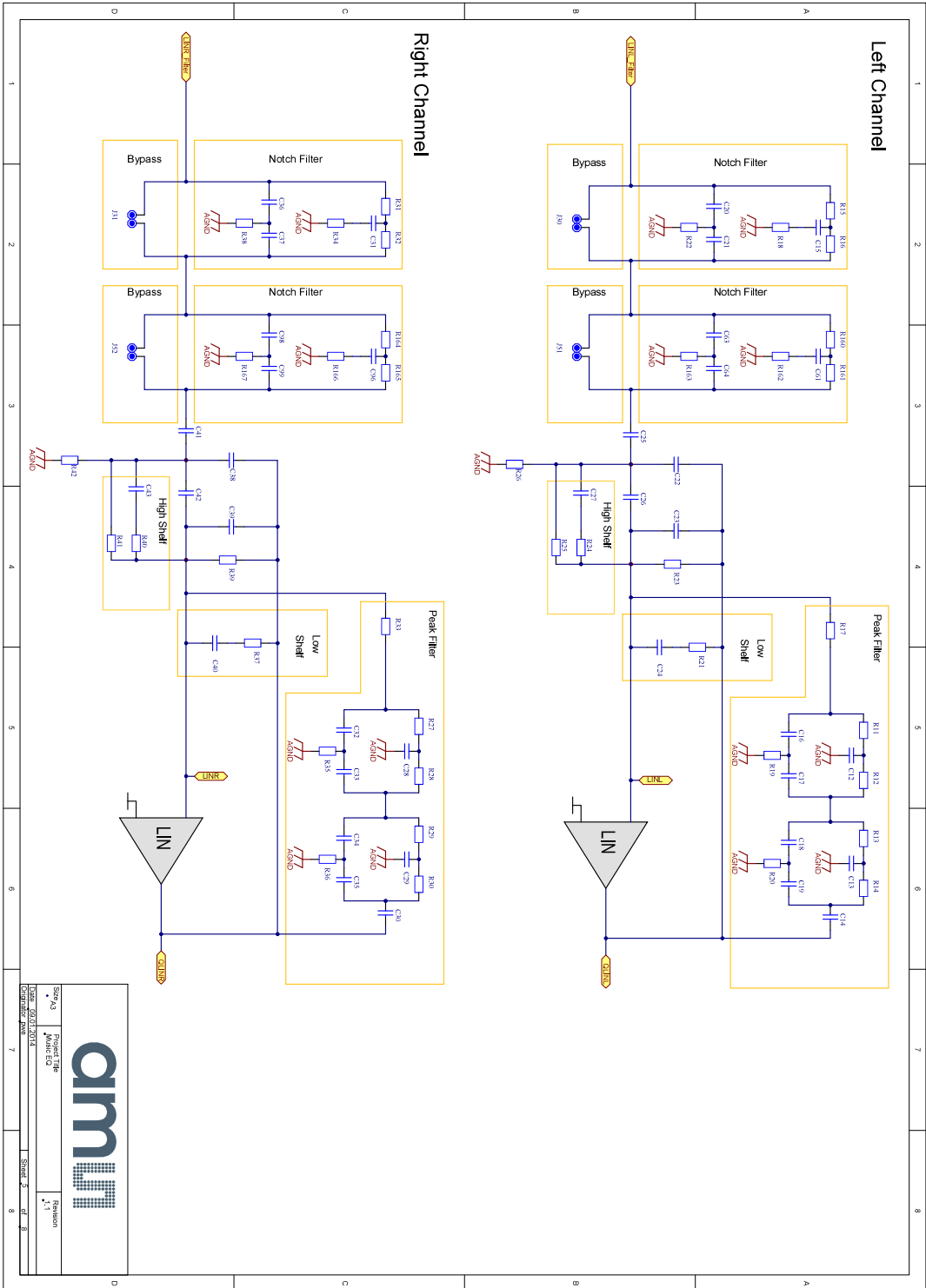

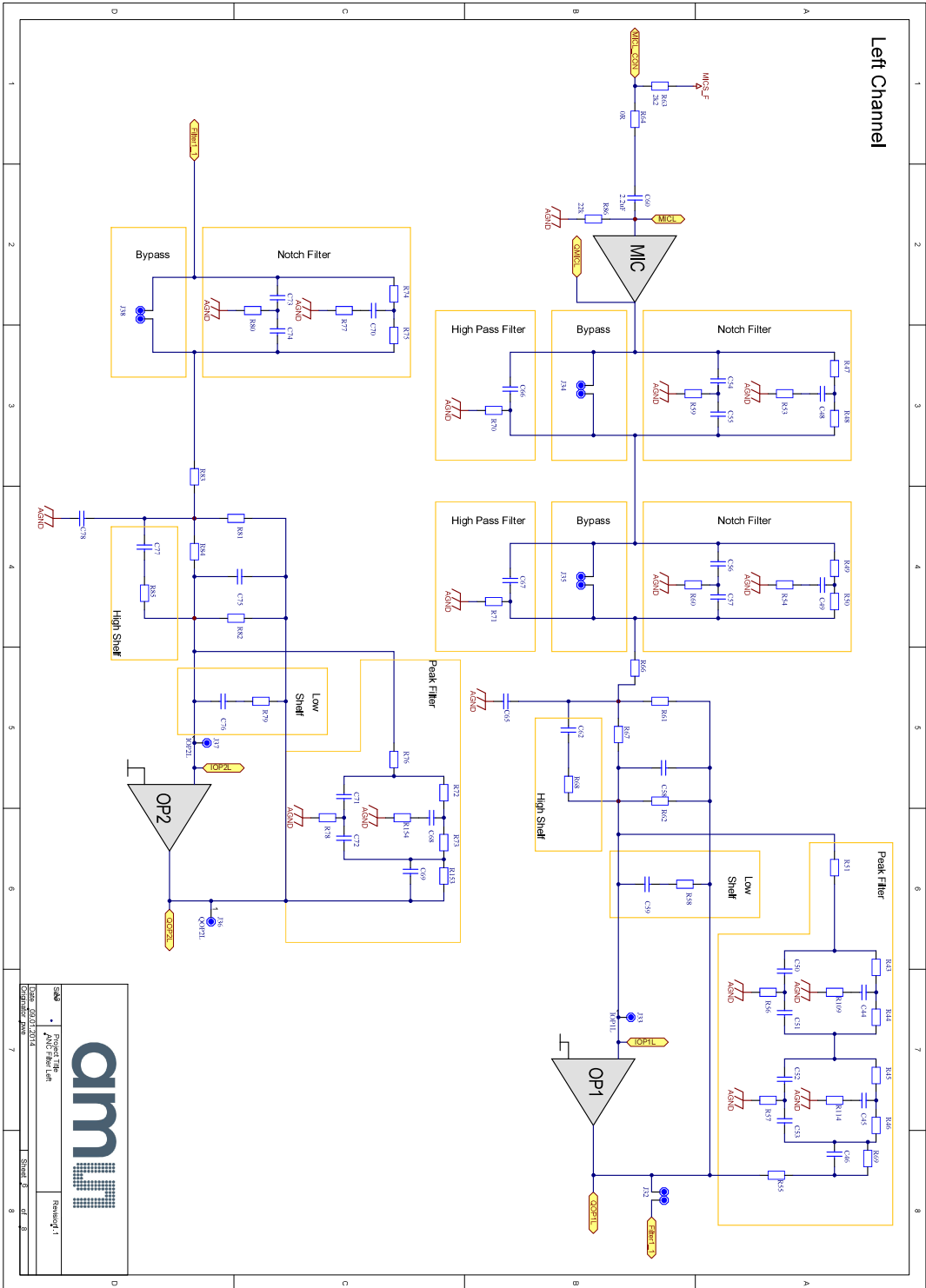

|   |  |   |   |
|---|--|---|---|
|  |  | Date: 2024.04.14<br>Drawn: 2024.04.14             | Sheet: 5<br>of: 8                                 |
|   |  | Rev: 1.1<br>Project Title: <b>am</b><br>Revision: | Rev: 1.1<br>Project Title: <b>am</b><br>Revision: |



  
 Project Title: \_\_\_\_\_  
 Project Lead: \_\_\_\_\_  
 Date: \_\_\_\_\_  
 Sheet 2 of 8  
 Revision: 1

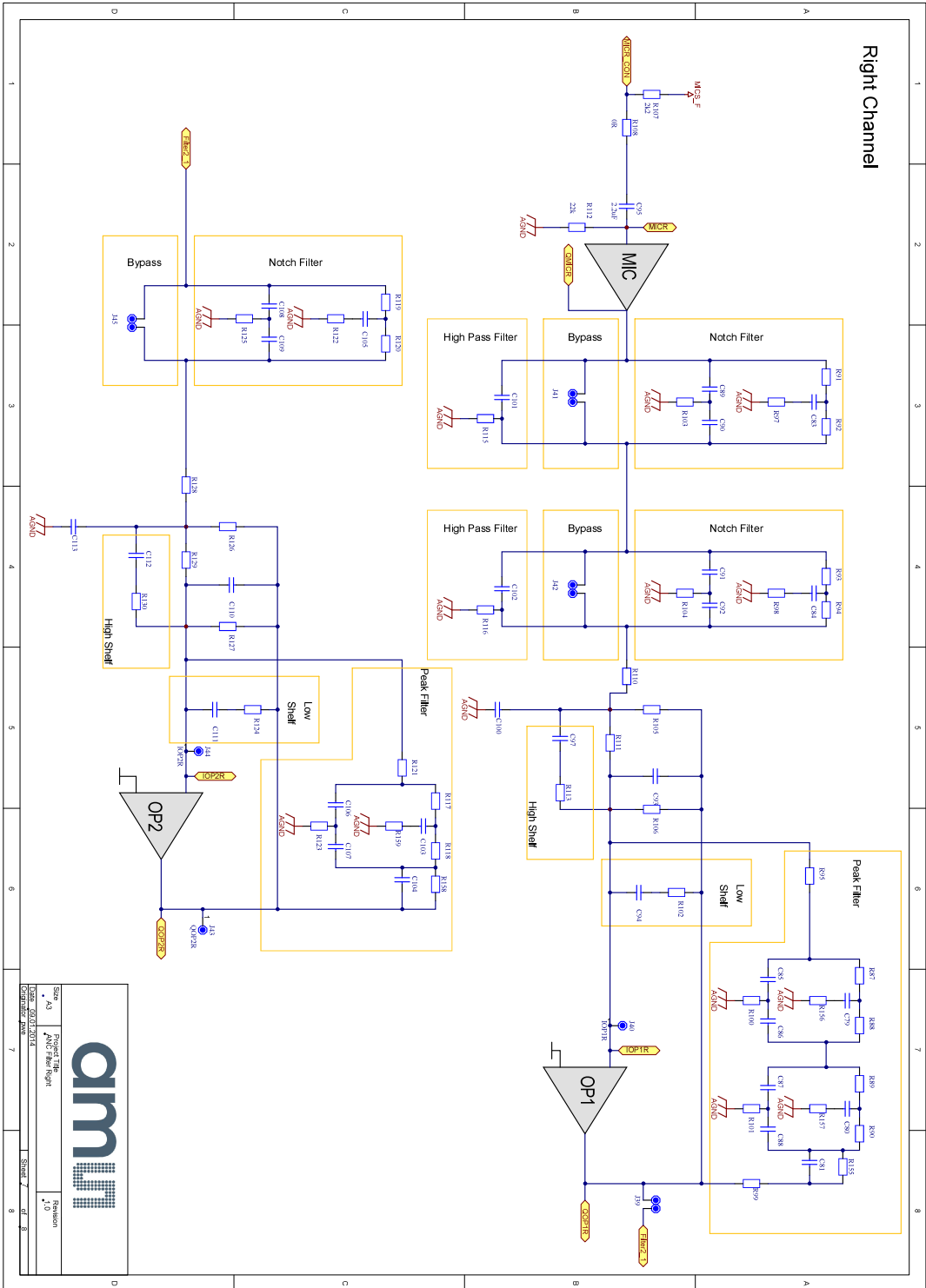

|   |  |                       |     |
|---|--|-----------------------|-----|
|  |  | Revizor               | 1.0 |
|   |  | Proiectant            |     |
| Sursa: 43<br>Proiect: Titlu<br>Nume: Faza Finala                                    |  | Sursa: 7<br>Nr. de: 8 |     |



## D Contents of Electronic Appendix

|                                |   |
|--------------------------------|---|
| / .....                        | Elektronická príloha  |
| AMS .....                      | AMS eval board datasheets and schematics                      |
| Filter simulation AMS .....    | Import files for AMS GUI (version 1.3.0.0), BOM               |
| measurements used .....        | all used measurements in thesis                               |
| Anechoic measurement .....     | excel files of measurements in anechoic chamber               |
| board and ANC evaluation ..... | excel files of filters and ANC measurements                   |
| Filter calculation .....       | FF and FB filters calculation in excel                        |
| charts .....                   | all used charts in excel files                                |
| in box measurements .....      | excel files of in box measurements                            |
| prve meranie .....             | first measurements of passive attenuation and headset drivers |
| PCB for MEMS .....             | PCB design, Eagle (9.6.2.) schematics, MEMS datasheet         |