

## A1-DIO/DO0 [CPU 1214C DC/DC/DC]

### A1-DIO/DO0

#### General\Project information

<b>Name</b>	A1-DIO/DO0	<b>Author</b>	Michal Lorenc
<b>Comment</b>		<b>Slot</b>	1
<b>Rack</b>	0		

#### General\Catalog information

<b>Short designation</b>	CPU 1214C DC/DC/DC	<b>Description</b>	Work memory 75 KB; 24VDC power supply with DI14 x 24VDC SINK/ SOURCE, DQ10 x 24VDC and AI2 on board; 6 high-speed counters and 4 pulse outputs on board; signal board expands on-board I/O; up to 3 communication modules for serial communication; up to 8 signal modules for I/O expansion; 0.04 ms/1000 instructions; PROFINET interface for programming, HMI and PLC-to-PLC communication
<b>Article number</b>	6ES7 214-1AG31-0XB0	<b>Firmware version</b>	V3.0

#### PROFINET interface\General\Project information

<b>Name</b>	PROFINET interface_1	<b>Comment</b>	
<b>Name</b>	DI 14/DQ 10_1	<b>Comment</b>	
<b>Name</b>	AI 2_1	<b>Comment</b>	

#### PROFINET interface\Ethernet addresses\Interface networked with

<b>Subnet:</b>	PN/IE_1		
----------------	---------	--	--

#### PROFINET interface\Ethernet addresses\IP protocol

<b>IP configuration</b>	Set IP address in the project	<b>IP address:</b>	192.168.0.1
<b>Subnet mask:</b>	255.255.255.0	<b>Use router</b>	False

#### PROFINET interface\Ethernet addresses\PROFINET

<b>PROFINET device name is set directly at the device</b>	False	<b>Generate PROFINET device name automatically</b>	True
<b>PROFINET device name:</b>	a1-dio/do0	<b>Converted name:</b>	a1-dioxrdo05d4a
<b>Device number:</b>	0		

#### PROFINET interface\Digital inputs\Input filters

<b>I0.0 - I0.3</b>	6.40ms	<b>I0.4 - I0.7</b>	6.40ms
<b>I1.0 - I1.3</b>	6.40ms	<b>I1.4 - I1.7</b>	6.40ms

#### PROFINET interface\Digital inputs\Channel0

<b>Channel address</b>	I0.0	<b>Enable rising edge detection</b>	0
<b>Enable falling edge detection</b>	0	<b>Enable pulse catch</b>	0

#### PROFINET interface\Digital inputs\Channel1

<b>Channel address</b>	I0.1	<b>Enable rising edge detection</b>	0
<b>Enable falling edge detection</b>	0	<b>Enable pulse catch</b>	0

#### PROFINET interface\Digital inputs\Channel2

<b>Channel address</b>	I0.2	<b>Enable rising edge detection</b>	0
<b>Enable falling edge detection</b>	0	<b>Enable pulse catch</b>	0

#### PROFINET interface\Digital inputs\Channel3

<b>Channel address</b>	I0.3	<b>Enable rising edge detection</b>	0
------------------------	------	-------------------------------------	---

Totally Integrated Automation Portal			
Enable falling edge detection	0	Enable pulse catch	0
PROFINET interface\Digital inputs\Channel4			
Channel address	I0.4	Enable rising edge detection	0
Enable falling edge detection	0	Enable pulse catch	0
PROFINET interface\Digital inputs\Channel5			
Channel address	I0.5	Enable rising edge detection	0
Enable falling edge detection	0	Enable pulse catch	0
PROFINET interface\Digital inputs\Channel6			
Channel address	I0.6	Enable rising edge detection	0
Enable falling edge detection	0	Enable pulse catch	0
PROFINET interface\Digital inputs\Channel7			
Channel address	I0.7	Enable rising edge detection	0
Enable falling edge detection	0	Enable pulse catch	0
PROFINET interface\Digital inputs\Channel8			
Channel address	I1.0	Enable rising edge detection	0
Enable falling edge detection	0	Enable pulse catch	0
PROFINET interface\Digital inputs\Channel9			
Channel address	I1.1	Enable rising edge detection	0
Enable falling edge detection	0	Enable pulse catch	0
PROFINET interface\Digital inputs\Channel10			
Channel address	I1.2	Enable rising edge detection	0
Enable falling edge detection	0	Enable pulse catch	0
PROFINET interface\Digital inputs\Channel11			
Channel address	I1.3	Enable rising edge detection	0
Enable falling edge detection	0	Enable pulse catch	0
PROFINET interface\Digital inputs\Channel12			
Channel address	I1.4	Enable pulse catch	0
PROFINET interface\Digital inputs\Channel13			
Channel address	I1.5	Enable pulse catch	0
PROFINET interface\Advanced options\Interface options			
Support device replacement without exchangeable medium	True	Use IEC V2.2 LLDP mode	True
PROFINET interface\Advanced options\Anchor (ParameterRealtimeSettingsMenu)			
The TreeNode ParameterRealtimeSettingsMenu was not filled by some ACF			
PROFINET interface\Advanced options\Port [X1 P1]\General\Project information			
Name	Port_1	Comment	
PROFINET interface\Advanced options\Port [X1 P1]\Port interconnection\Local port:			
Local port:	A1-DIO/DO0\PROFINET interface_1 [X1]\Port_1 [X1 P1]	Medium:	Copper

Totally Integrated Automation Portal			
Cable name: ---			
			
<b>PROFINET interface\Advanced options\Port [X1 P1]\Port interconnection\Partner port:</b>			
	Monitoring of partner port is not possible	<b>Partner port:</b>	Any partner
<b>PROFINET interface\Advanced options\Port [X1 P1]\Port options\Activate</b>			
<b>Activate this port for use</b>	True		
<b>PROFINET interface\Advanced options\Port [X1 P1]\Port options\Connection</b>			
<b>Transmission rate / duplex:</b>	Automatic	<b>Monitor</b>	False
<b>Enable autonegotiation</b>	True		
<b>PROFINET interface\Advanced options\Port [X1 P1]\Port options\Boundaries</b>			
<b>End of detection of accessible devices</b>	False	<b>End of topology discovery</b>	False
<b>End of the sync domain</b>	False		
<b>PROFINET interface\Analog inputs\Noise reduction</b>			
<b>Integration time</b>	50 Hz (20 ms)		
<b>PROFINET interface\Analog inputs\Channel0</b>			
<b>Channel address</b>	IW64	<b>Measurement type</b>	Voltage
<b>Voltage range</b>	0..10 V	<b>Smoothing</b>	Weak (4 cycles)
<b>Empty</b>		<b>Enable overflow diagnostics</b>	1
<b>PROFINET interface\Analog inputs\Channel1</b>			
<b>Channel address</b>	IW66	<b>Measurement type</b>	Voltage
<b>Voltage range</b>	0..10 V	<b>Smoothing</b>	Weak (4 cycles)
<b>Empty</b>		<b>Enable overflow diagnostics</b>	1
<b>PROFINET interface\Digital outputs</b>			
<b>Reaction to CPU STOP</b>	Use substitute value		
<b>PROFINET interface\Digital outputs\Channel0</b>			
<b>Channel address</b>	Q0.0	<b>Substitute a value of 1 on a change from RUN to STOP.</b>	0
<b>PROFINET interface\Digital outputs\Channel1</b>			
<b>Channel address</b>	Q0.1	<b>Substitute a value of 1 on a change from RUN to STOP.</b>	0
<b>PROFINET interface\Digital outputs\Channel2</b>			
<b>Channel address</b>	Q0.2	<b>Substitute a value of 1 on a change from RUN to STOP.</b>	0
<b>PROFINET interface\Digital outputs\Channel3</b>			
<b>Channel address</b>	Q0.3	<b>Substitute a value of 1 on a change from RUN to STOP.</b>	0
<b>PROFINET interface\Digital outputs\Channel4</b>			
<b>Channel address</b>	Q0.4	<b>Substitute a value of 1 on a change from RUN to STOP.</b>	0

Totally Integrated Automation Portal			
<b>PROFINET interface\Digital outputs\Channel5</b>			
Channel address	Q0.5	Substitute a value of 1 on a change from RUN to STOP.	0
<b>PROFINET interface\Digital outputs\Channel6</b>			
Channel address	Q0.6	Substitute a value of 1 on a change from RUN to STOP.	0
<b>PROFINET interface\Digital outputs\Channel7</b>			
Channel address	Q0.7	Substitute a value of 1 on a change from RUN to STOP.	0
<b>PROFINET interface\Digital outputs\Channel8</b>			
Channel address	Q1.0	Substitute a value of 1 on a change from RUN to STOP.	0
<b>PROFINET interface\Digital outputs\Channel9</b>			
Channel address	Q1.1	Substitute a value of 1 on a change from RUN to STOP.	0
<b>PROFINET interface\Time synchronization</b>			
Enable time synchronization via NTP server	Enable time synchronization via NTP server		IP addresses
Server 1	0.0.0.0	Server 2	0.0.0.0
Server 3	0.0.0.0	Server 4	0.0.0.0
Update interval	10sec		
<b>PROFINET interface\I/O addresses\Input addresses</b>			
Start address	0.0	End address	1.7
Process image	Cyclic PI		
<b>PROFINET interface\I/O addresses\Input addresses</b>			
Start address	64	End address	67
Process image	Cyclic PI		
<b>PROFINET interface\I/O addresses\Output addresses</b>			
Start address	0.0	End address	1.7
Process image	Cyclic PI		
<b>High speed counters (HSC)\HSC1\General\Enable</b>			
Enable this high speed counter	0	Enable this high speed counter	0
Enable this high speed counter	0	Enable this high speed counter	0
Enable this high speed counter	0	Enable this high speed counter	0
<b>High speed counters (HSC)\HSC1\General\Project information</b>			
Name	HSC_1	Comment	
Name	HSC_2	Comment	
Name	HSC_3	Comment	
Name	HSC_4	Comment	
Name	HSC_5	Comment	
Name	HSC_6	Comment	
<b>High speed counters (HSC)\HSC1\I/O addresses\Input addresses</b>			
Start address	1000.0	End address	1003.7
Start address	1004.0	End address	1007.7
Process image	Cyclic PI	Start address	1008.0
End address	1011.7	Process image	Cyclic PI
Start address	1012.0	End address	1015.7
Process image	Cyclic PI	Start address	1016.0
End address	1019.7	Process image	Cyclic PI
Start address	1020.0	End address	1023.7
Process image	Cyclic PI	Process image	Cyclic PI

Totally Integrated Automation Portal					
<b>Pulse generators (PTO/PWM)\PTO1/PWM1\General\Enable</b>					
Enable this pulse generator	0	Enable this pulse generator	0		
<b>Pulse generators (PTO/PWM)\PTO1/PWM1\General\Project information</b>					
Name	Pulse_1	Comment			
Name	Pulse_2	Comment			
<b>Pulse generators (PTO/PWM)\PTO1/PWM1\I/O addresses\Output addresses</b>					
Start address	1000.0	End address	1001.7		
Start address	1002.0	End address	1003.7		
Process image	Cyclic PI	Process image	Cyclic PI		
<b>Startup</b>					
Startup after POWER ON	Warm restart - mode before POWER OFF	Comparison preset to actual configuration	Startup CPU even if mismatch		
Configuration time	60000ms				
<b>Cycle</b>					
Cycle monitoring time	150ms				
Enable minimum cycle time for cyclic OBs	0	Minimum cycle time	1ms		
<b>Communication load</b>					
Cycle load due to communication	20%				
<b>System and clock memory\System memory bits</b>					
Enable the use of system memory byte	1	Address of system memory byte (MBx)	1		
First cycle	%M1.0 (FirstScan)	Diagnostic status changed	%M1.1 (DiagStatusUpdate)		
Always 1 (high)	%M1.2 (AlwaysTRUE)	Always 0 (low)	%M1.3 (AlwaysFALSE)		
<b>System and clock memory\Clock memory bits</b>					
Enable the use of clock memory byte	1	Address of clock memory byte (MBx)	0		
10 Hz clock	%M0.0 (Clock_10Hz)	5 Hz clock	%M0.1 (Clock_5Hz)		
2.5 Hz clock	%M0.2 (Clock_2.5Hz)	2 Hz clock	%M0.3 (Clock_2Hz)		
1.25 Hz clock	%M0.4 (Clock_1.25Hz)	1 Hz clock	%M0.5 (Clock_1Hz)		
0.625 Hz clock	%M0.6 (Clock_0.625Hz)	0.5 Hz clock	%M0.7 (Clock_0.5Hz)		
<b>Web server\General</b>					
Activate web server on this module	False	Permit access only with HTTPS	False		
<b>Web server\Automatic update</b>					
Enable automatic update	True	Update interval	0s		
<b>Web server\User-defined web pages</b>					
Application name	HTML source path	Default HTML page	Files with dynamic content	Web DB number	Fragment DB number
		index.htm	.htm;.html	333	334
<b>Overview of addresses\Overview of addresses\Overview of addresses</b>					
Inputs	True	Outputs	True		
Address gaps	False	Slot	True		

Type	Addr. from	Addr. to	Module	PIP	Device name	Device number	Size	Master / IO system	Rack	Slot
I	0	1	DI 14/DQ 10_1	-	A1-DIO/DO0 [CPU 1214C DC/DC/DC]	-	2 Bytes	-	0	1 1
O	0	1	DI 14/DQ 10_1	-	A1-DIO/DO0 [CPU 1214C DC/DC/DC]	-	2 Bytes	-	0	1 1
I	64	67	AI 2_1	-	A1-DIO/DO0 [CPU 1214C DC/DC/DC]	-	4 Bytes	-	0	1 2
I	1000	1003	HSC_1	-	A1-DIO/DO0 [CPU 1214C DC/DC/DC]	-	4 Bytes	-	0	1 16
I	1004	1007	HSC_2	-	A1-DIO/DO0 [CPU 1214C DC/DC/DC]	-	4 Bytes	-	0	1 17
I	1008	1011	HSC_3	-	A1-DIO/DO0 [CPU 1214C DC/DC/DC]	-	4 Bytes	-	0	1 18
I	1012	1015	HSC_4	-	A1-DIO/DO0 [CPU 1214C DC/DC/DC]	-	4 Bytes	-	0	1 19
I	1016	1019	HSC_5	-	A1-DIO/DO0 [CPU 1214C DC/DC/DC]	-	4 Bytes	-	0	1 20
I	1020	1023	HSC_6	-	A1-DIO/DO0 [CPU 1214C DC/DC/DC]	-	4 Bytes	-	0	1 21
O	1000	1001	Pulse_1	-	A1-DIO/DO0 [CPU 1214C DC/DC/DC]	-	2 Bytes	-	0	1 32
O	1002	1003	Pulse_2	-	A1-DIO/DO0 [CPU 1214C DC/DC/DC]	-	2 Bytes	-	0	1 33
O	1004	1005	Pulse_3	-	A1-DIO/DO0 [CPU 1214C DC/DC/DC]	-	2 Bytes	-	0	1 34
O	1006	1007	Pulse_4	-	A1-DIO/DO0	-	2 Bytes	-	0	1 35

Type	Addr. from	Addr. to	Module	PIP	Device name	Device number	Size	Master / IO system	Rack	Slot
					[CPU 1214C DC/DC/DC]					
I	8	9	A1-DI1	-	A1-DIO/DO0 [CPU 1214C DC/DC/DC]	-	2 Bytes	-	0	2
I	12	13	A-DI2	-	A1-DIO/DO0 [CPU 1214C DC/DC/DC]	-	2 Bytes	-	0	3
O	16	16	A1-DO1	-	A1-DIO/DO0 [CPU 1214C DC/DC/DC]	-	1 Bytes	-	0	4
O	20	20	A1-DO2	-	A1-DIO/DO0 [CPU 1214C DC/DC/DC]	-	1 Bytes	-	0	5

**Time of day\Local time**

**Time zone** (UTC +01:00) Berlin, Bern, Brussels, Rome, Stockholm, Vienna

**Time of day\Daylight saving time**

**Activate daylight saving time** 0 **Difference between standard and daylight saving time** 60mins

**Time of day\Daylight saving time\Start of daylight saving time**

**Starting week of the month:** Last **of** March **at** 01:00 a.m. **Sunday**

**Time of day\Daylight saving time\Start of standard time**

**of** Last **at** 02:00 a.m. **Sunday**

**Protection\**

**Level of protection** No protection

**Protection\Password for read/write access**

**Password** **Confirm password**

**Connection resources**

**PG communication:** 1 **OP communication:** 1  
**S7 basic communication:** 0 **S7 communication:** 0  
**Maximum number of S7 connection resources:** 32

**Anchor (AddressesOverviewMenu)**

The AddressesOverviewMenu was not filled by some ACF

## A1-DIO/DO0 [CPU 1214C DC/DC/DC] / Program blocks

### 010 Main [OB1]

#### 010 Main Properties

##### General

<b>Name</b>	010 Main	<b>Number</b>	1	<b>Type</b>	OB
<b>Language</b>	LAD	<b>Numbering</b>	Automatic		

##### Information

<b>Title</b>	"Main Program Sweep (Cycle)"	<b>Author</b>		<b>Comment</b>	Chyba nad cílovým senzorem zajistit, oprava seřetování bitu porucha
<b>Family</b>		<b>Version</b>	0.1	<b>User-defined ID</b>	

Name	Data type	Default value	Comment
Temp			
Constant			

#### Network 1: Volání funkce stav linky

Na kontrolu při začátku a zprovoznění odmazat volání všech funkcí.  
Přes Force table všechno zkusit a pak jenom doházet funkce do OB1 a zkoušet.

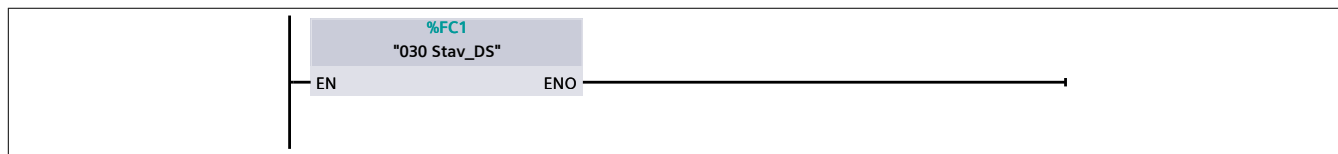

#### Network 2: Volání signalizace

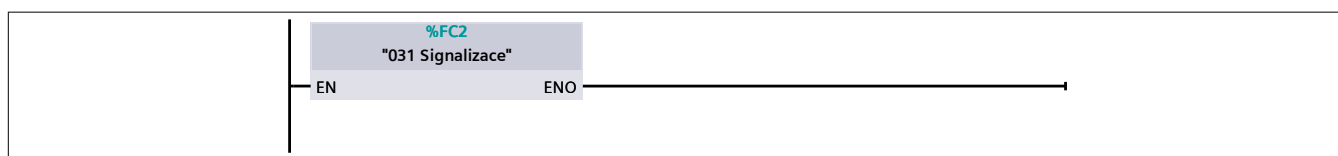

#### Network 3: Volání Automat

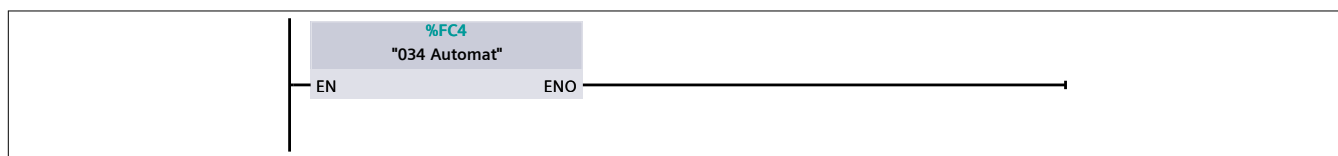

## A1-DIO/DO0 [CPU 1214C DC/DC/DC] / Program blocks

### 020 Startup [OB100]

#### 020 Startup Properties

##### General

<b>Name</b>	020 Startup	<b>Number</b>	100	<b>Type</b>	OB
<b>Language</b>	LAD	<b>Numbering</b>	Automatic		

##### Information

<b>Title</b>	"Complete Restart"	<b>Author</b>		<b>Comment</b>	Provede se pouze při první spuštění, odpojení napájení nebo po restartu CPU.
<b>Family</b>		<b>Version</b>	0.1	<b>User-defined ID</b>	

Name	Data type	Default value	Comment
▼ Input			
LostRetentive	Bool		True if retentive data are lost
LostRTC	Bool		True if date and time are lost
Temp			
Constant			

## A1-DIO/DO0 [CPU 1214C DC/DC/DC] / Program blocks

### 030 Stav\_DS [FC1]

#### 030 Stav\_DS Properties

##### General

<b>Name</b>	030 Stav_DS	<b>Number</b>	1	<b>Type</b>	FC
<b>Language</b>	LAD	<b>Numbering</b>	Automatic		

##### Information

<b>Title</b>		<b>Author</b>		<b>Comment</b>	Funkce zjišťuje stav nouzových tlačítek, hlavního vypínače, napájení, jističů, pojistek a přepětové ochrany. Dále funkce přepíná do stavu Linka porucha nebo Linka připravena.
<b>Family</b>		<b>Version</b>	0.1	<b>User-defined ID</b>	

Name	Data type	Default value	Comment
Input			
Output			
InOut			
Temp			
Constant			
▼ Return			
030 Stav_DS	Void		

#### Network 1: Stav nouzových tlačítek

Nouzová tlačítka jsou rozpínací

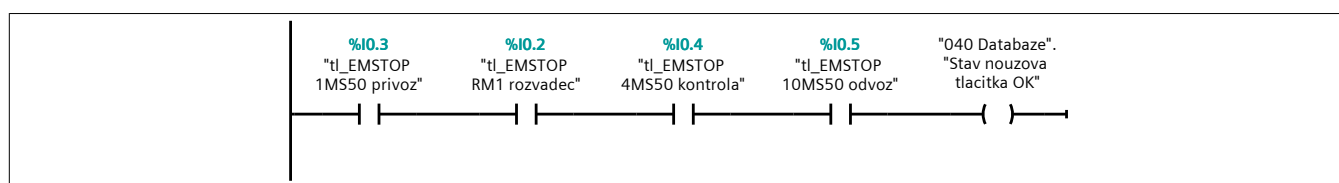

#### Network 2: Stav hlavního spínače

Pokud je zařízení zapnuto stav je v 1.

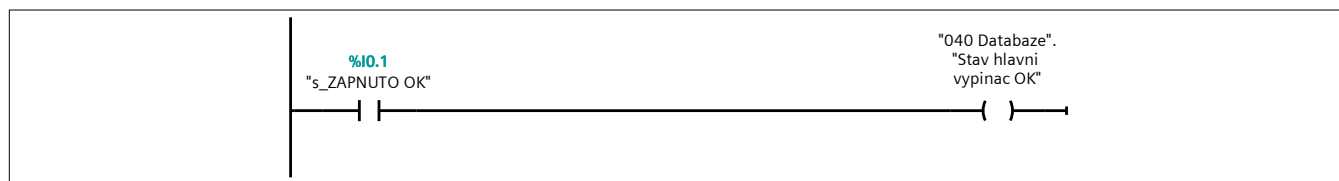

#### Network 3: Stav napájení 24V

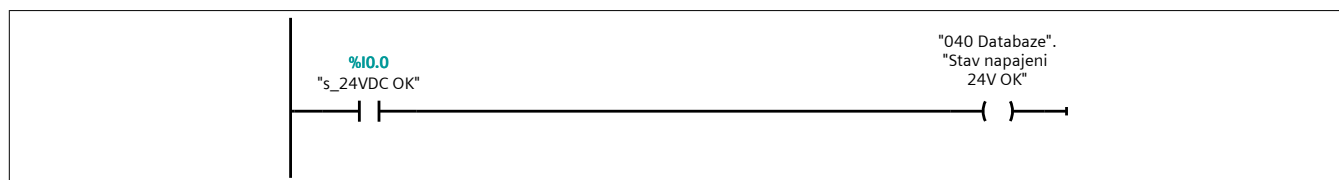

### Network 4: Stav jističů

Jističe : -1QM1, -2QM1, -3QM1, -4QM1, -5QM1, -6QM1, -7QM1, -8QM1, -9QM1, -10QM1

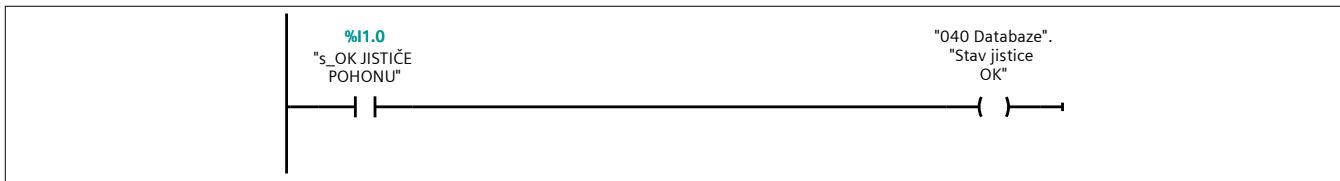

### Network 5: Stav pojistek

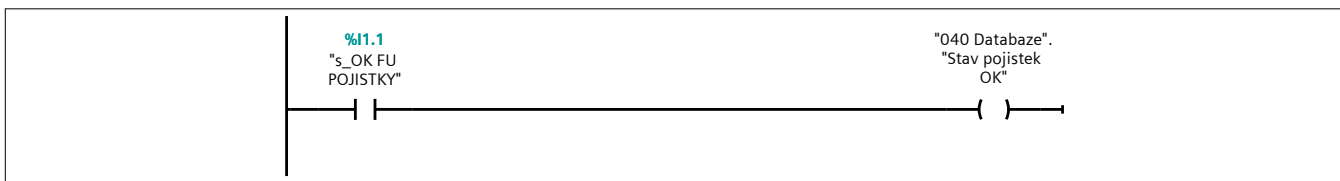

### Network 6: Stav přepětové ochrany předělat

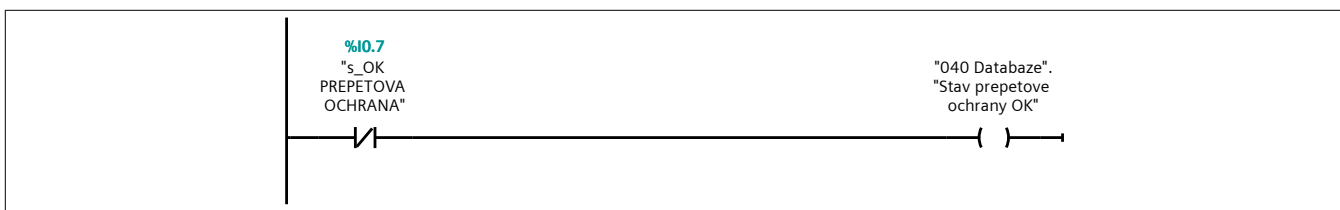

### Network 7: Linka detekce poruchy - setování bitu Linka porucha

Pokud je jeden stav v 0 dojde k setování bitu Linka porucha

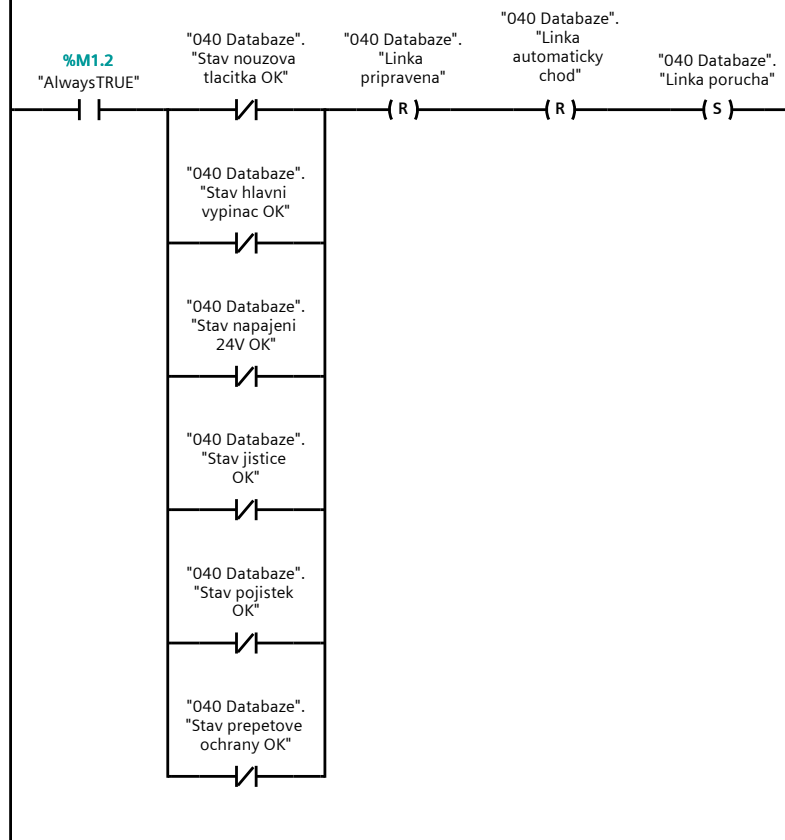

**Network 8: Linka detekce poruchy - resetování bitu Linka porucha, setování bitu Linka pripravena**

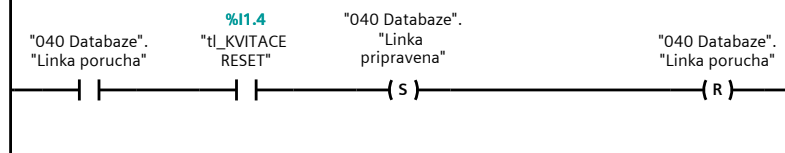

**Network 9: Zapnutí linky na automatický chod (automat)**

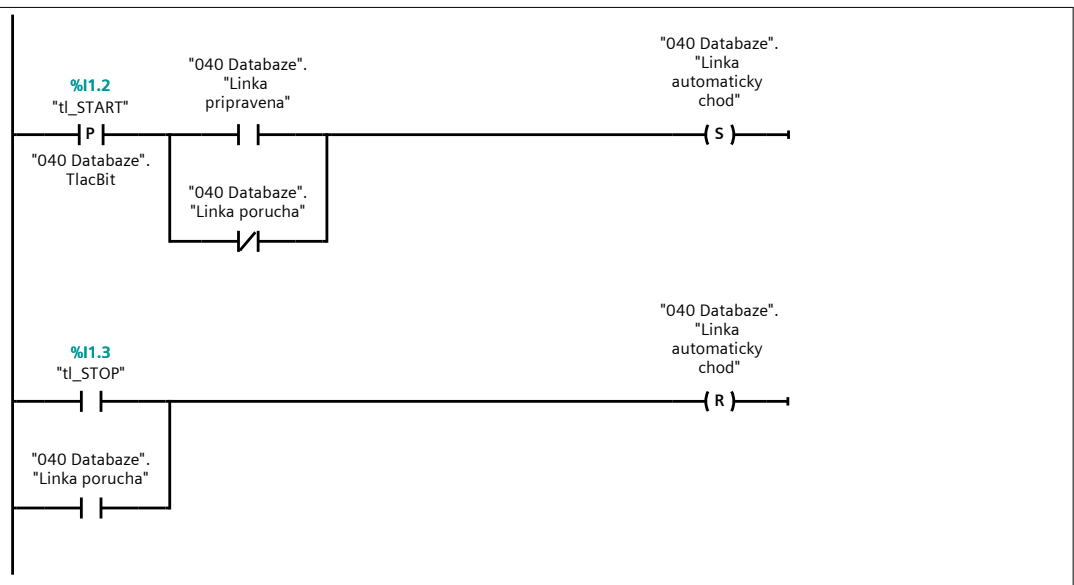

## A1-DIO/DO0 [CPU 1214C DC/DC/DC] / Program blocks

### 040 Databaze [DB1]

#### 040 Databaze Properties

##### General

<b>Name</b>	040 Databaze	<b>Number</b>	1	<b>Type</b>	DB
<b>Language</b>	DB	<b>Numbering</b>	Automatic		

##### Information

<b>Title</b>		<b>Author</b>		<b>Comment</b>	
<b>Family</b>		<b>Version</b>	0.1	<b>User-defined ID</b>	

Name	Data type	Start value	Retain	Access-ible from HMI/O PC UA	Wri-table from HM I/O PC UA	Visible in HMI engineering	Set-point	Super-vision	Comment
▼ Static									
Stav nouzova tla-citka OK	Bool	false	False	True	True	True	False		
InvertBit	Bool	false	False	True	True	True	False		
BlokujPrejezdPalet	Bool	false	False	True	True	True	False		
NuceneOdpojeni	Bool	false	False	True	True	True	False		
HelpBit00	Bool	false	False	True	True	True	False		
VozikPlny	Bool	false	False	True	True	True	False		
HelpBitPre-jezdD10_D11	Bool	false	False	True	True	True	False		
CidloNaD11	Bool	false	False	True	True	True	False		
Stav jistice OK	Bool	false	False	True	True	True	False		
Stav pojistek OK	Bool	false	False	True	True	True	False		
Stav hlavni vypi-nac OK	Bool	false	False	True	True	True	False		
Stav napajeni 24V OK	Bool	false	False	True	True	True	False		
Stav prepetove ochrany OK	Bool	false	False	True	True	True	False		
Linka pripravena	Bool	false	False	True	True	True	False		
Linka porucha	Bool	false	False	True	True	True	False		
Linka automaticky chod	Bool	false	False	True	True	True	False		
TlacBit	Bool	false	False	True	True	True	False		
InicializaceDokon-cena	Bool	false	False	True	True	True	False		

Name	Data type	Start value	Retain	Access-ible from HMI/O PC UA	Wri-ta-ble from HM I/O PC UA	Visible in HMI engi-neer-ing	Set-point	Super-vision	Comment
InicializaceProbiha	Bool	false	False	True	True	True	False		
InicializaceMotory	Bool	false	False	True	True	True	False		
TlacBit1	Bool	false	False	True	True	True	False		
bit0	Bool	false	False	True	True	True	False		
bit1	Bool	false	False	True	True	True	False		
bit2	Bool	false	False	True	True	True	False		
bit3	Bool	false	False	True	True	True	False		
bit4	Bool	false	False	True	True	True	False		
Stavl0	Bool	false	False	True	True	True	False		
Stavl1	Bool	false	False	True	True	True	False		
Stavl2	Bool	false	False	True	True	True	False		
Stavl3	Bool	false	False	True	True	True	False		
Stavl4	Bool	false	False	True	True	True	False		
Stavl5	Bool	false	False	True	True	True	False		
Stavl6	Bool	false	False	True	True	True	False		
BitProVozikOdvoz	Bool	false	False	True	True	True	False		
BitProVozikPrivoz	Bool	false	False	True	True	True	False		

## A1-DIO/DO0 [CPU 1214C DC/DC/DC] / Program blocks

### 031 Signalizace [FC2]

#### 031 Signalizace Properties

##### General

<b>Name</b>	031 Signalizace	<b>Number</b>	2	<b>Type</b>	FC
<b>Language</b>	LAD	<b>Numbering</b>	Automatic		

##### Information

<b>Title</b>	Ovládání kontrolky - zatím jen na rozvaděči	<b>Author</b>		<b>Comment</b>	
<b>Family</b>		<b>Version</b>	0.1	<b>User-defined ID</b>	

Name	Data type	Default value	Comment
Input			
Output			
InOut			
Temp			
Constant			
▼ Return			
031 Signalizace	Void		

#### Network 1: Signalizační sloupek - GREEN

Linka je v automatu (v provozu) nebo inicializuje

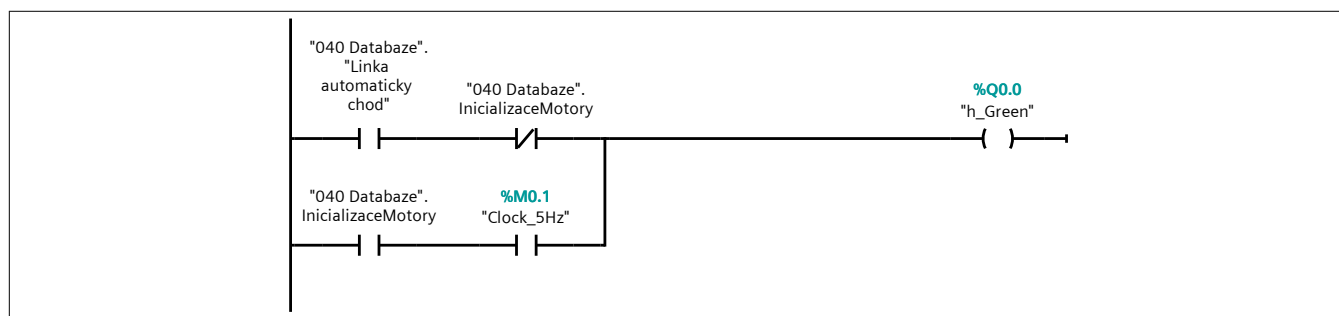

#### Network 2: Signalizační sloupek - RED

Porucha na straně jističů, pojistek, přepět'ové ochrany, napájení 24V nebo hlavního spínače.

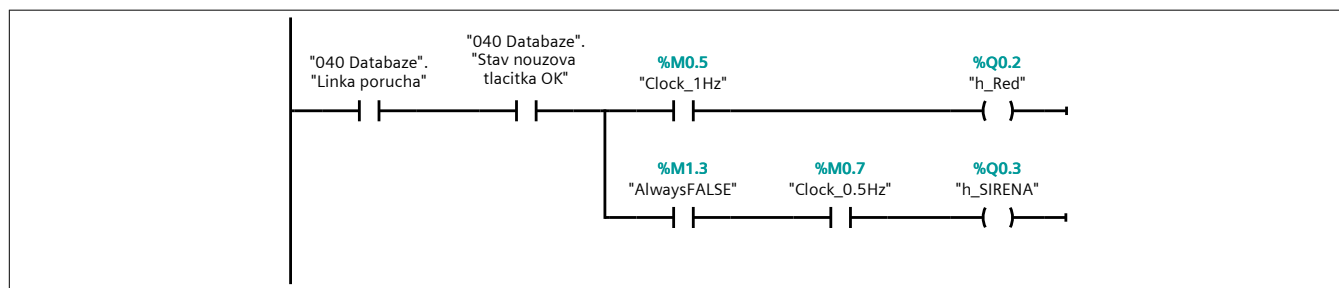

#### Network 3: Signalizační sloupek - YELLOW

Kontrolka indikuje zamáčknuté nouzové tlačítko.

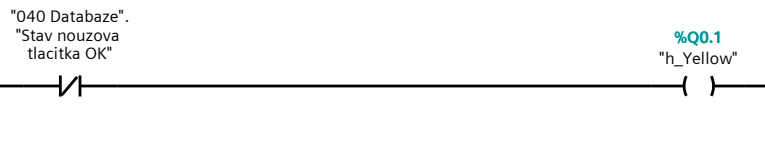

### Network 4: Kontrolka-stanice přívozu - ODEŠLI

Bliká pokud je vozík zaaretován a přechází resp vykonává se přejezd na vozík.  
Svítí pokud je dopravník D1 volný.

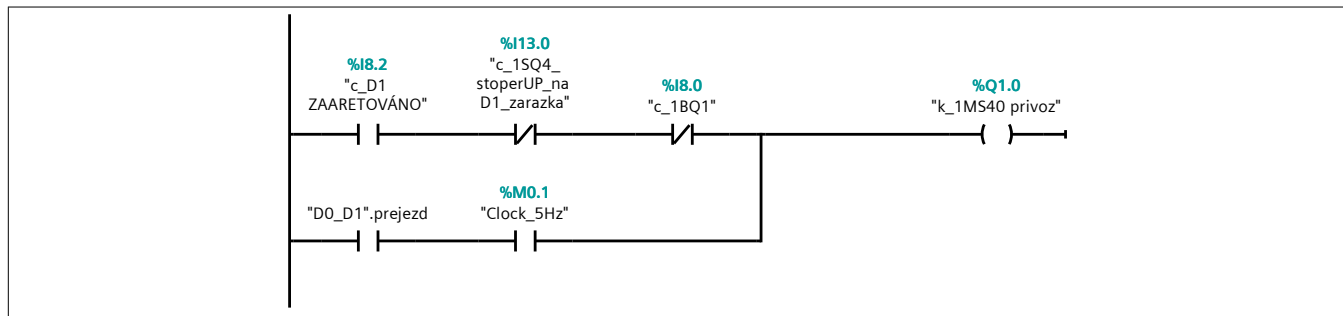

### Network 5: Kontrolka-stanice kontroly - ODEŠLI

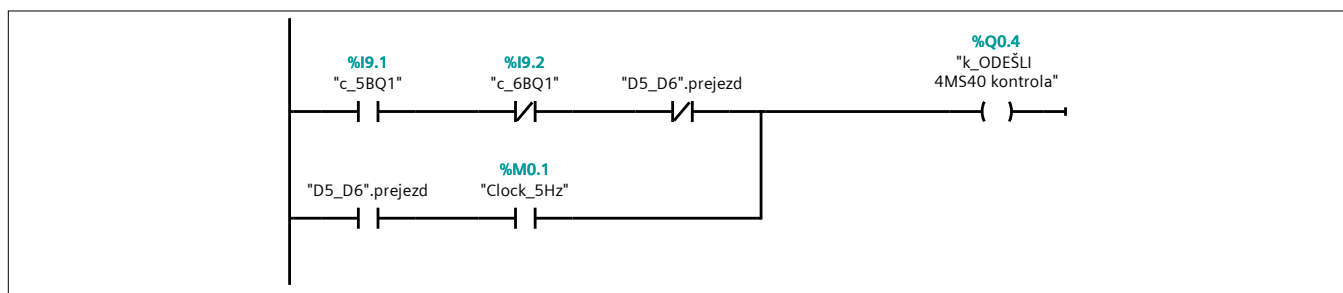

### Network 6: Kontrolka-stanice kontroly - BLOKUJ

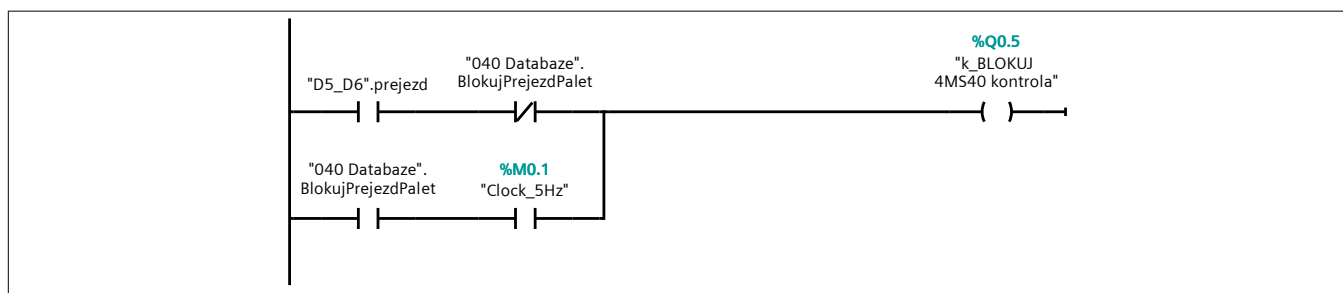

### Network 7: Kontrolka-stanice vyřazení - ODEŠLI

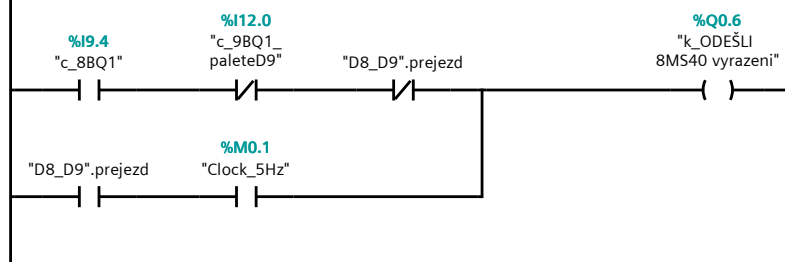

### Network 8: Kontrolka-stanice vyřazení - BLOKUJ

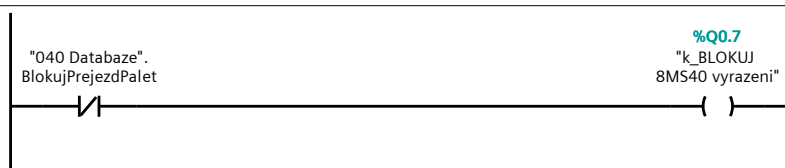

### Network 9: Kontrolka-stanice odvozu - ODEŠLI

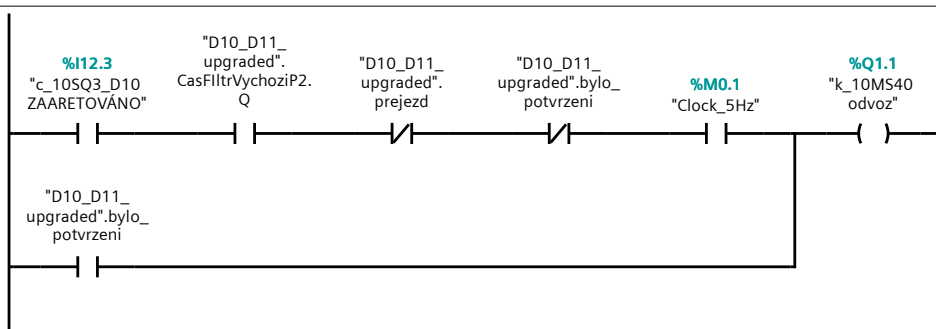

## A1-DIO/DO0 [CPU 1214C DC/DC/DC] / Program blocks

### 041 Automat [DB5]

#### 041 Automat Properties

##### General

<b>Name</b>	041 Automat	<b>Number</b>	5	<b>Type</b>	DB
<b>Language</b>	DB	<b>Numbering</b>	Automatic		

##### Information

<b>Title</b>		<b>Author</b>		<b>Comment</b>	
<b>Family</b>		<b>Version</b>	0.1	<b>User-defined ID</b>	

Name	Data type	Start value	Retain	Access-ible from HMI/O PC UA	Wri-ta-ble from HM I/O PC UA	Visible in HMI engi-neer-ing	Set-point	Super- vision	Comment
▼ Static									
Jistenizacatek	Bool	false	False	True	True	True	False		
Jistenikonec	Bool	false	False	True	True	True	False		
Stav0	Bool	false	False	True	True	True	False		paleta přidávání
Stav1	Bool	false	False	True	True	True	False		paleta přidávání
Stav2	Bool	false	False	True	True	True	False		paleta přidávání
Stav3	Bool	false	False	True	True	True	False		paleta přidávání
Stav4	Bool	false	False	True	True	True	False		paleta přidávání
Stav5	Bool	false	False	True	True	True	False		paleta přidávání
Stav6	Bool	false	False	True	True	True	False		paleta přidávání
StavZakaz	Bool	false	False	True	True	True	False		paleta přidávání
StavV0	Bool	false	False	True	True	True	False		paleta odebírání
StavV1	Bool	false	False	True	True	True	False		paleta odebírání
StavV2	Bool	false	False	True	True	True	False		paleta odebírání
StavV3	Bool	false	False	True	True	True	False		paleta odebírání
StavV4	Bool	false	False	True	True	True	False		paleta odebírání
StavV5	Bool	false	False	True	True	True	False		paleta odebírání
StavV6	Bool	false	False	True	True	True	False		paleta odebírání
StavVZakaz	Bool	false	False	True	True	True	False		paleta odebírání

Name	Data type	Start value	Retain	Access- sible from HMI/O PC UA	Wri- ta- ble fro- m HM I/O PC UA	Visible in HMI	Set- point	Super- vision	Comment
StavBlokaceK	Bool	true	False	True	True	True	False		kontrola
StavBlokaceO	Bool	true	False	True	True	True	False		odstranění
StavBlokaceB	Bool	true	False	True	True	True	False		balení D9
BitPrivolej	Bool	false	False	True	True	True	False		

## A1-DIO/DO0 [CPU 1214C DC/DC/DC] / Program blocks

### 034 Automat [FC4]

#### 034 Automat Properties

##### General

<b>Name</b>	034 Automat	<b>Number</b>	4	<b>Type</b>	FC
<b>Language</b>	LAD	<b>Numbering</b>	Automatic		

##### Information

<b>Title</b>	TOHLE JE MAIN AUTOMAT	<b>Author</b>		<b>Comment</b>	<p>Linka je ve stavu Automat tedy je v provozu.</p> <p>Automat 1 =&gt; základní ovládání (trochu inteligentnější) Příjem mačká se tlačítko po zajištění vozíku a pak se zapne dopravník. Kontrolní stanice odesílá tlačítkem, další paleta přijede automaticky, tlač. blokuje k ničemu. Vyřazovací stanoviště pro odeslání palety se zmáčkne odešli, zastavuje zde každá paleta. Na D9 balení zastaví každá paleta a tlačítkem přivolej se posílá na D10.</p>
<b>Family</b>		<b>Version</b>	0.1	<b>User-defined ID</b>	

Name	Data type	Default value	Comment
Input			
Output			
InOut			
Temp			
Constant			
▼ Return			
034 Automat	Void		

#### Network 1: Inicializace

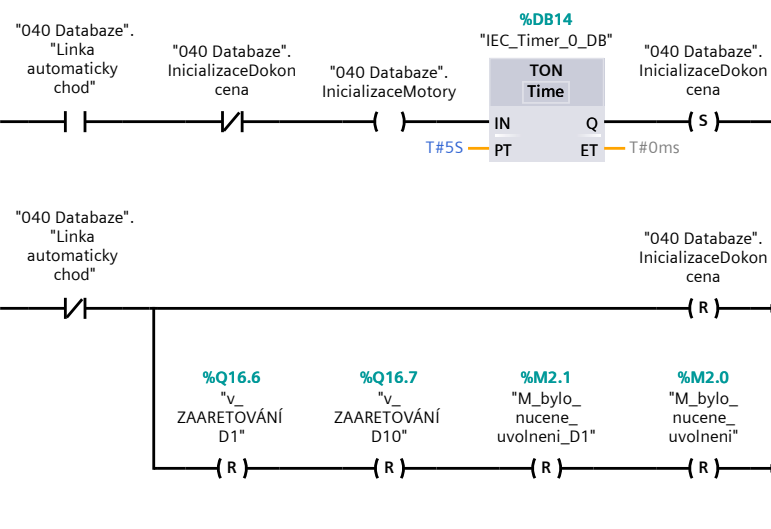

### Network 2: Přejezd D0 - D1 PŘÍVOZ VOZÍKEM

BlokaceNaVoziku kontakt upravit podle toho jestli to bude sepnutý nebo rozepnutý když bude blokace aktivní. Je to podmínka přejezdu D10\_D11

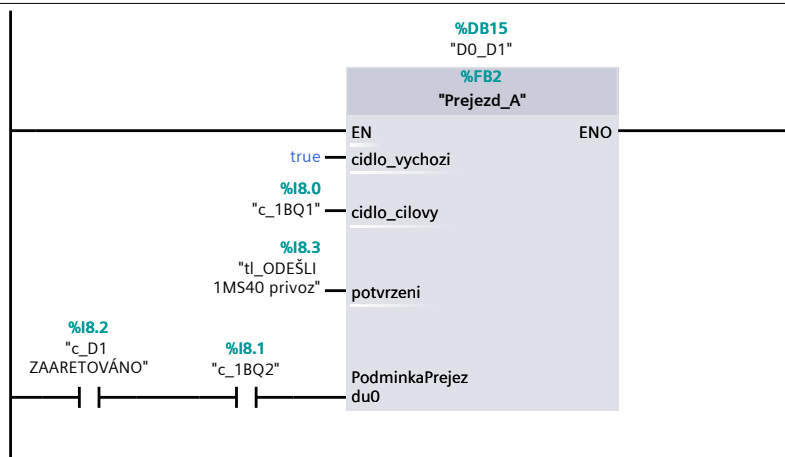

### Network 3: Přejezd D1 - D2

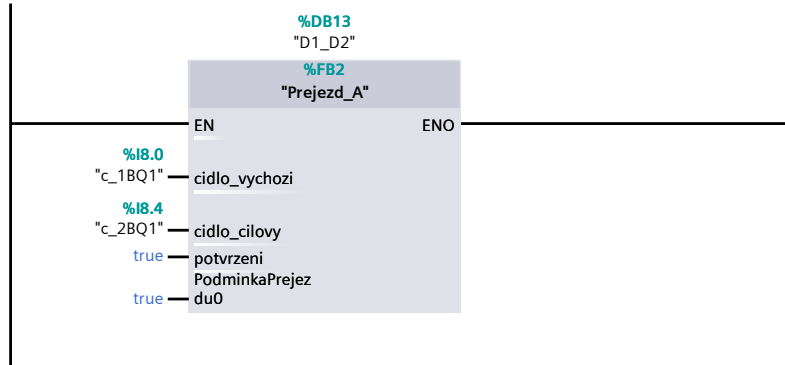

### Network 4: Přejezd D2 - D3

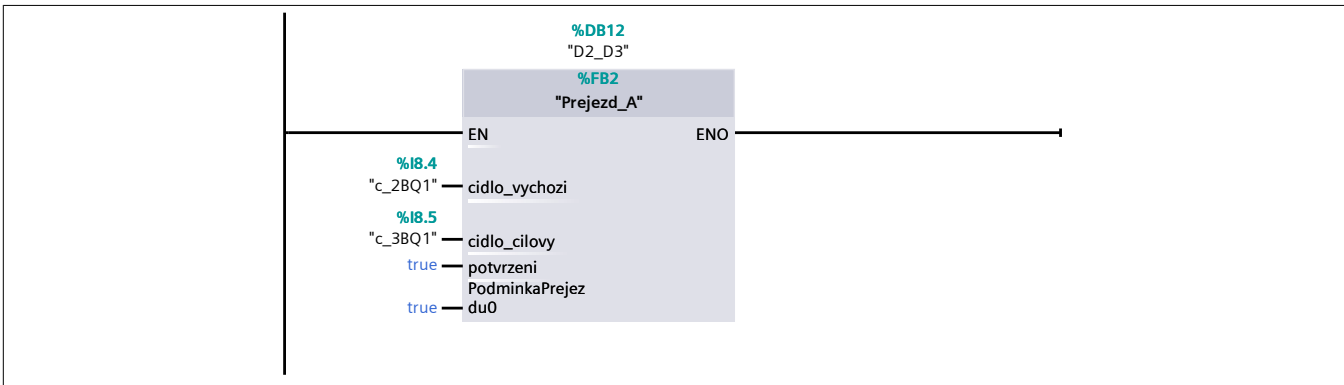

**Network 5: Přejezd D3 - D4**

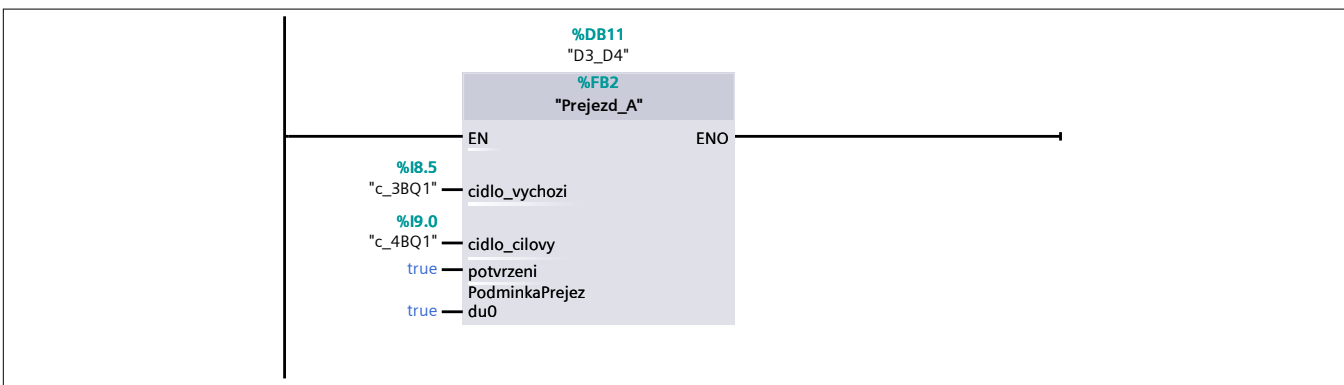

**Network 6: Přejezd D4 - D5**

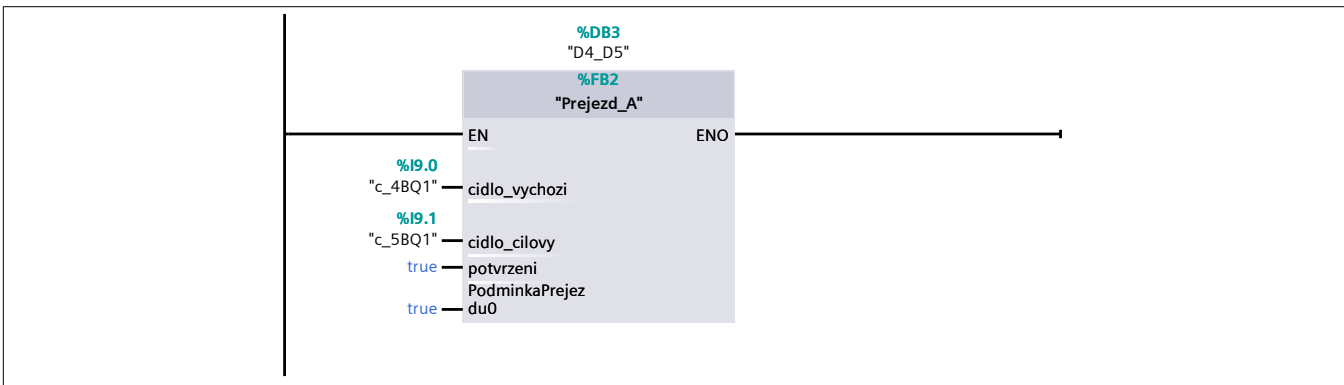

**Network 7: Přejezd D5 - D6**

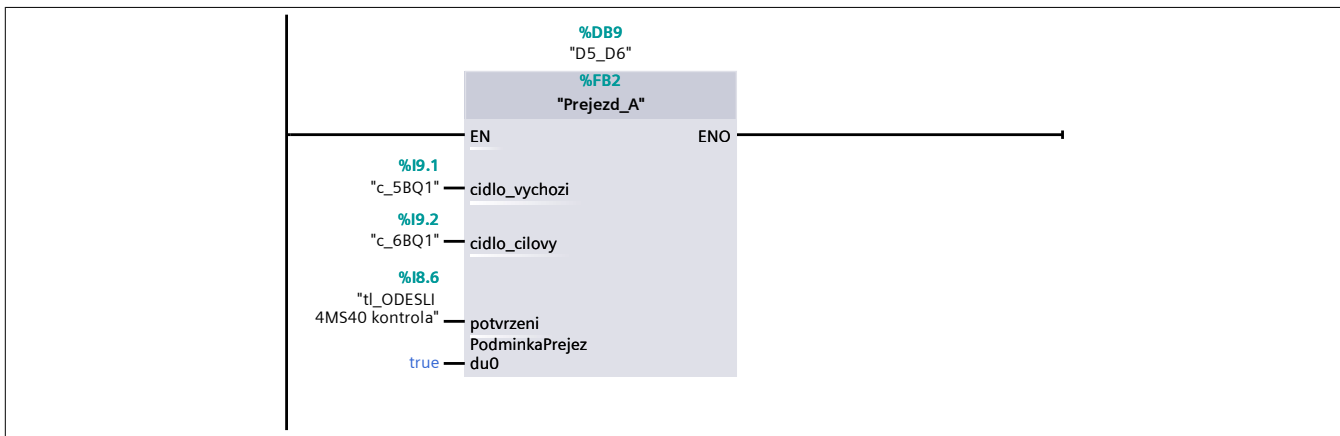

**Network 8: Přejezd D6 - D7**

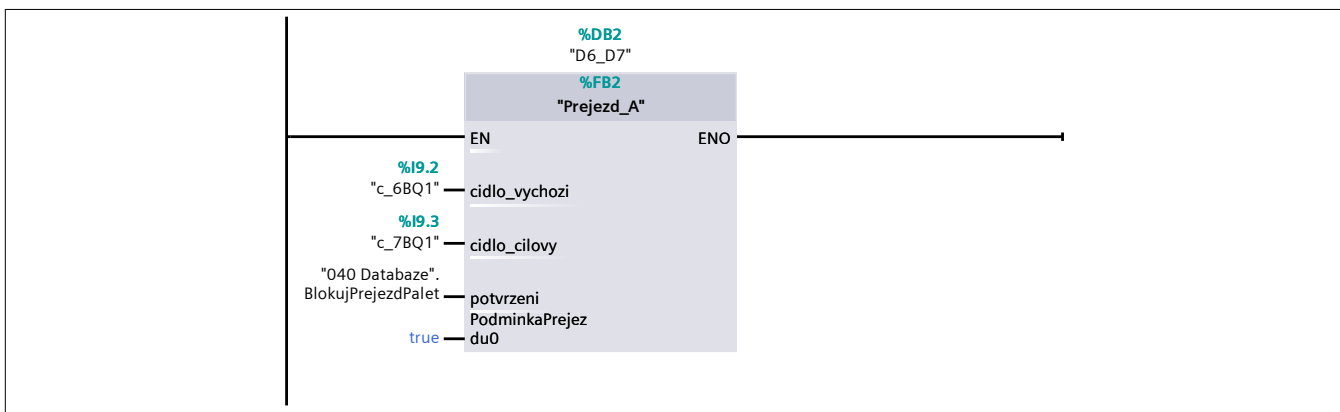

**Network 9: Přejezd D7 - D8**

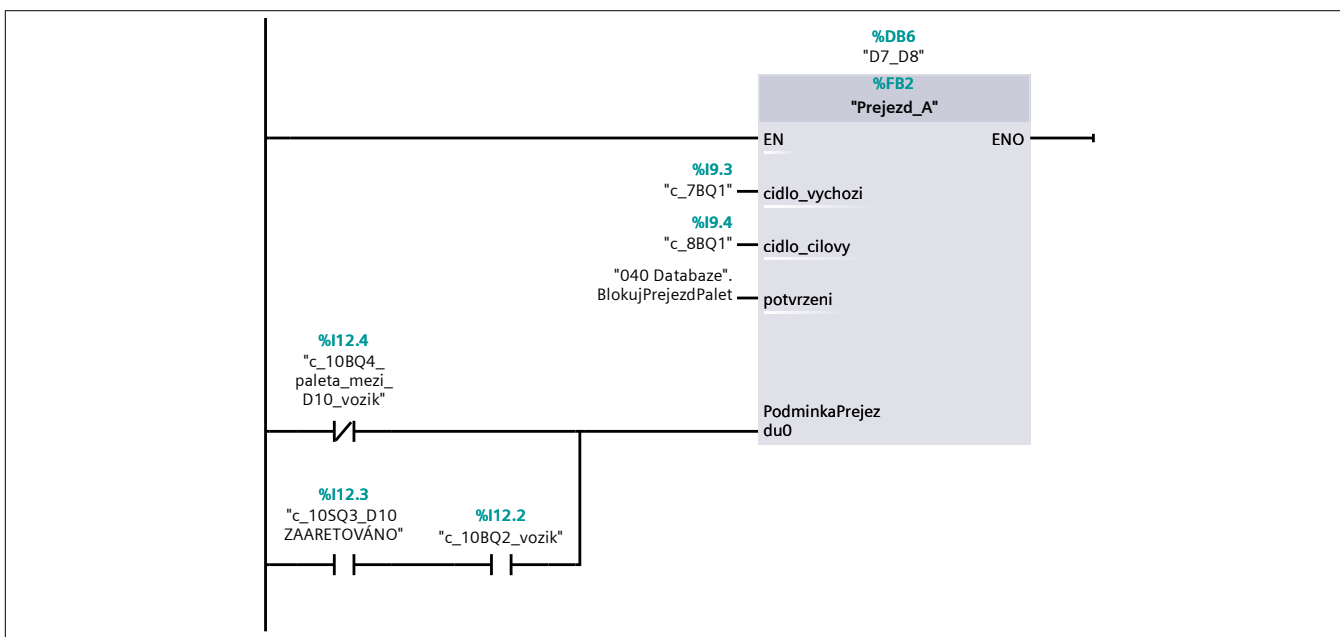

**Network 10: Přejezd D8 - D9**

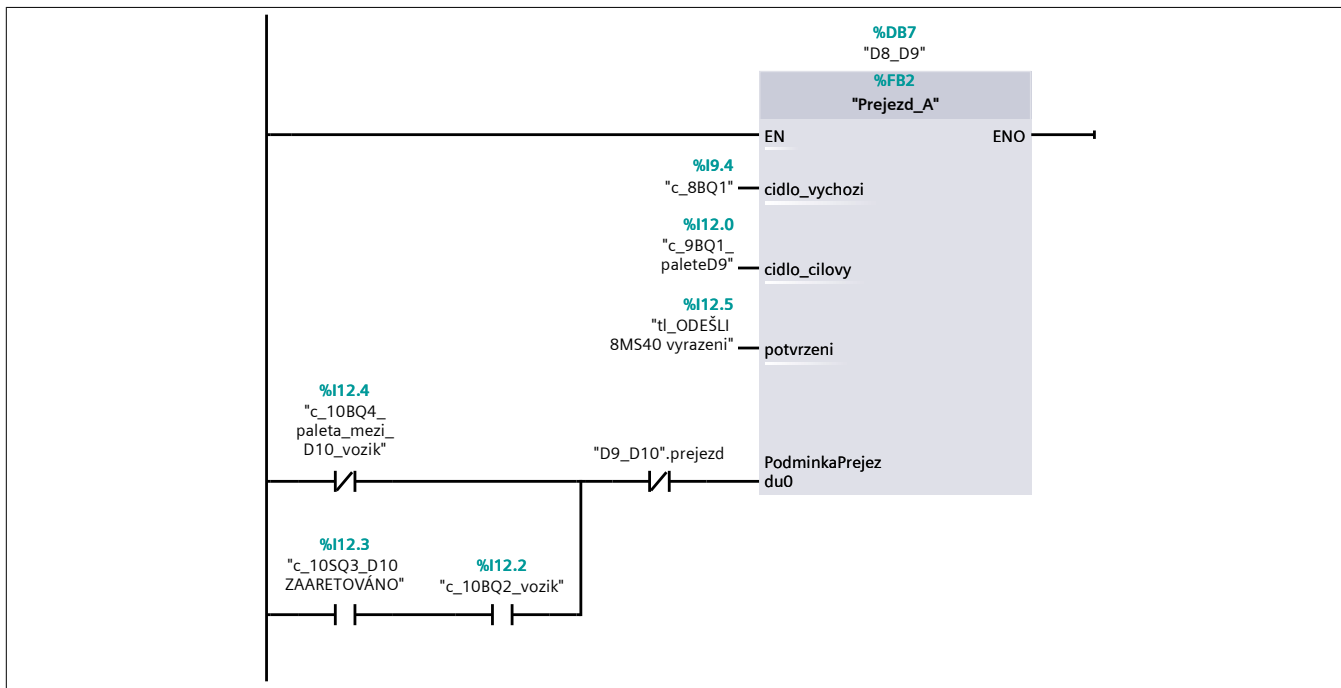

Network 11: Přejezd D9 - D10

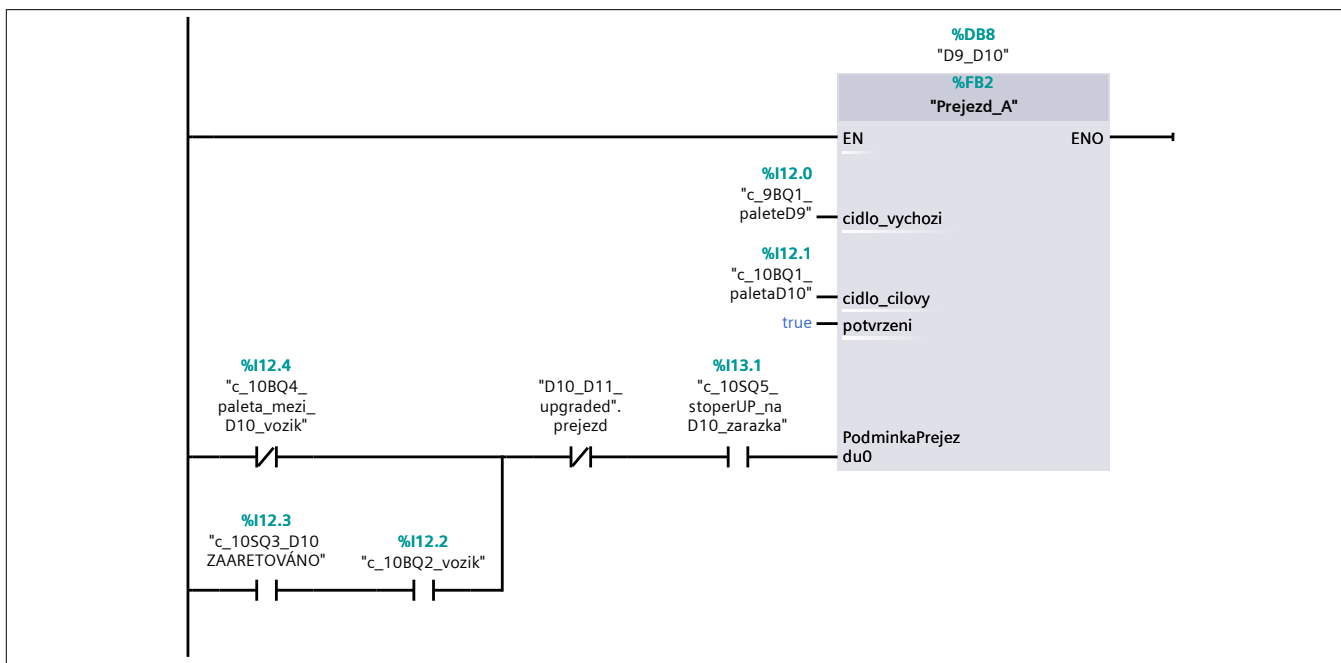

Network 12: Přejezd D10 - D11 ODVOZ VOZÍKEM

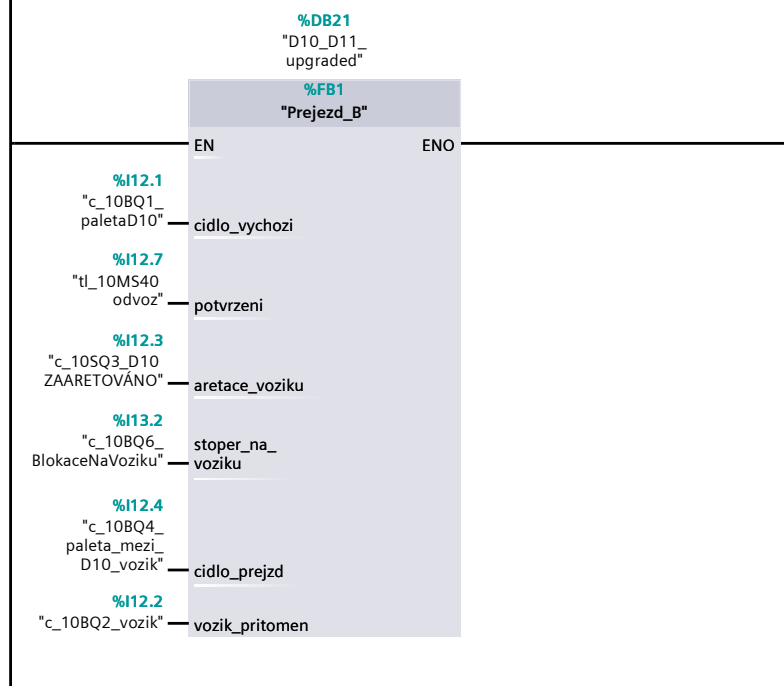

### Network 13: Blokování přejezdů mezi D6 až D8

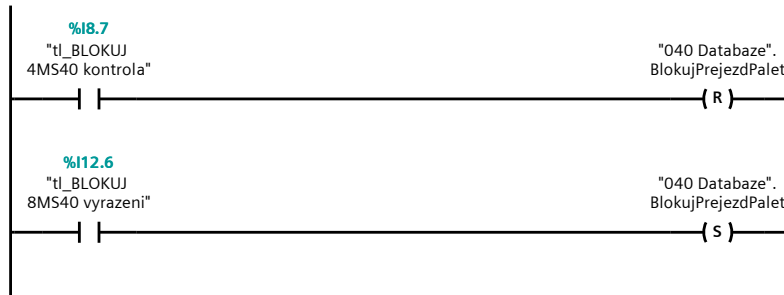

### Network 14: Detekce poruchy na nějakém přejezdu

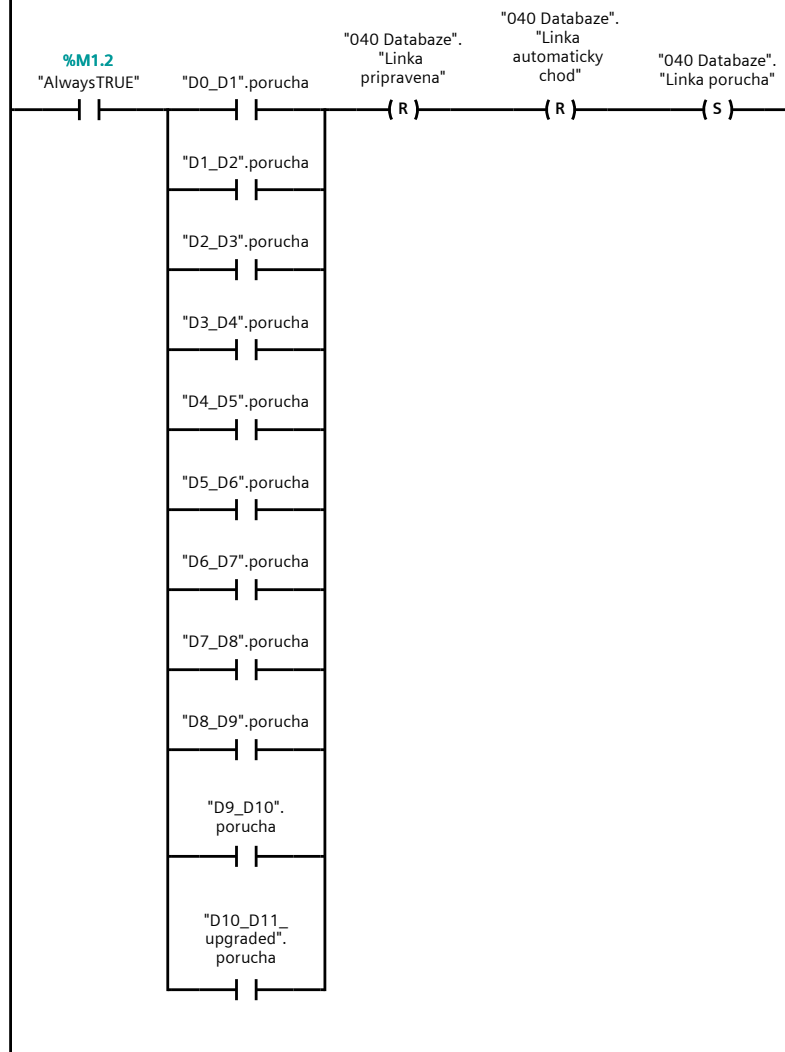

### Network 15: Motor 1 - D1

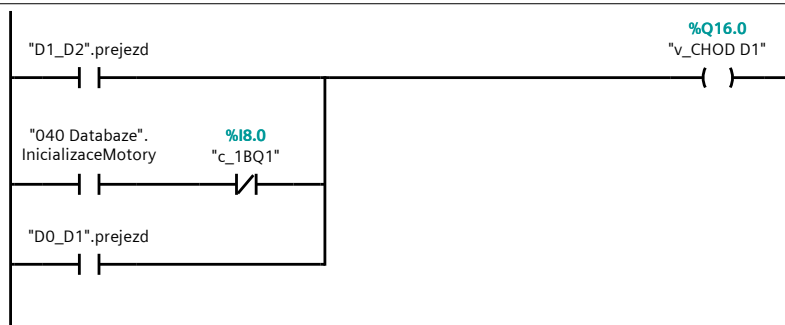

### Network 16: Motor 2 - D2

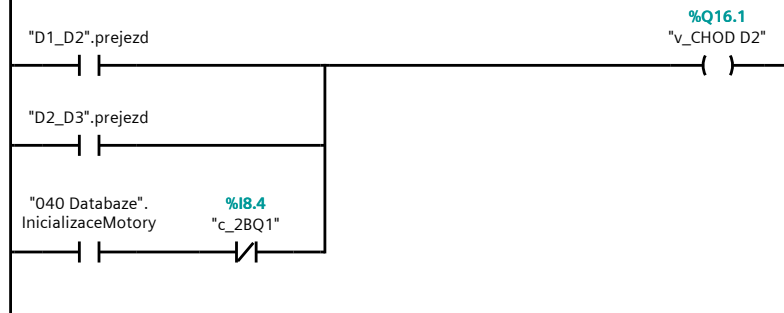

**Network 17: Motor 3 - D3**

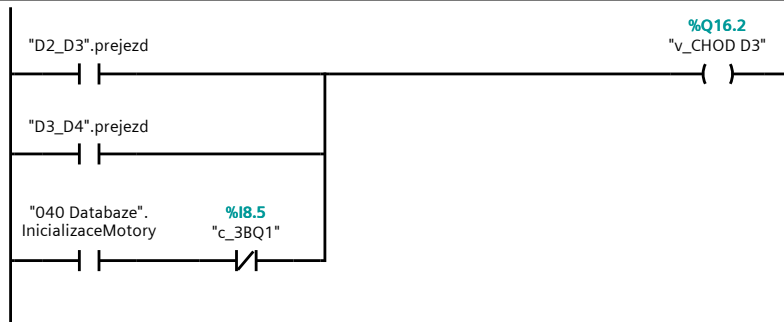

**Network 18: Motor 4 - D4**

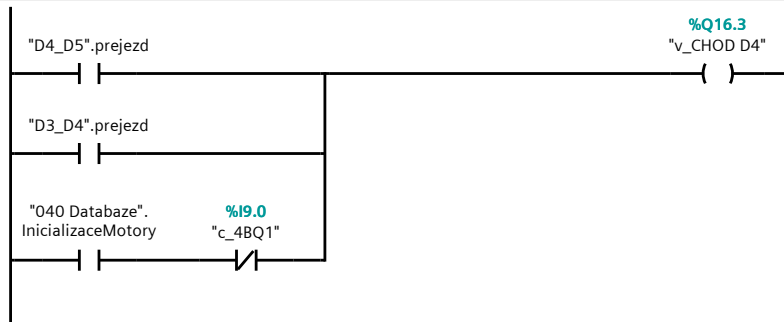

**Network 19: Motor 5 - D5**

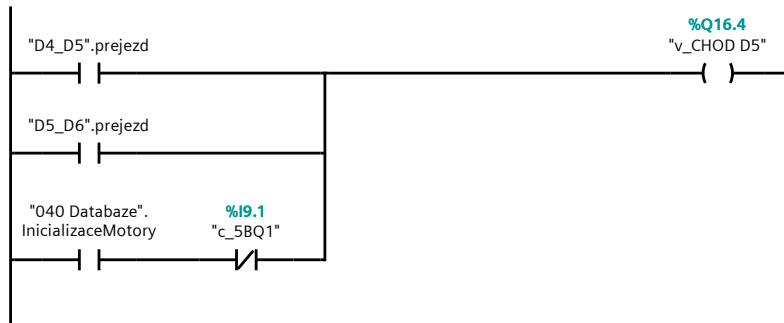

**Network 20: Motor 6 - D6**

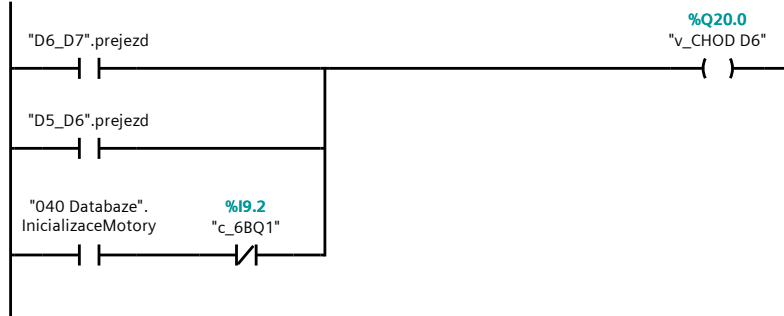

### Network 21: Motor 7 - D7

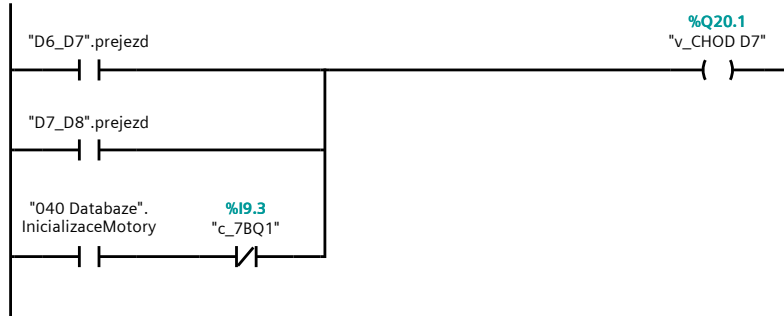

### Network 22: Motor 8 - D8

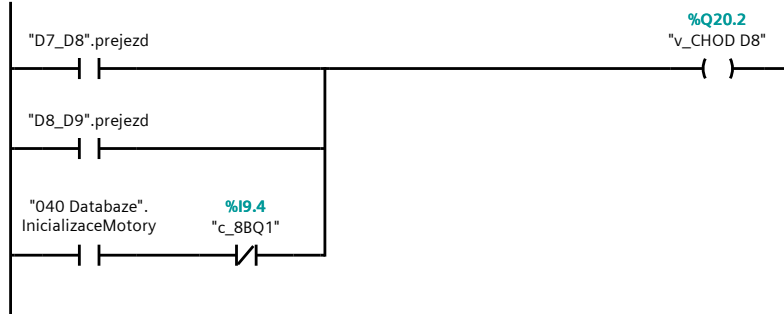

### Network 23: Motor 9 - D9

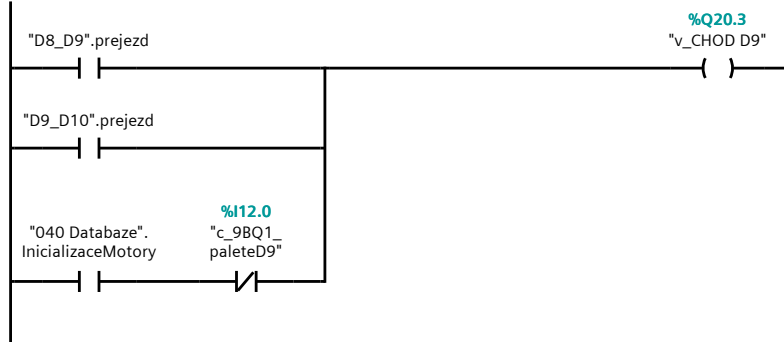

### Network 24: Motor 10 - D10

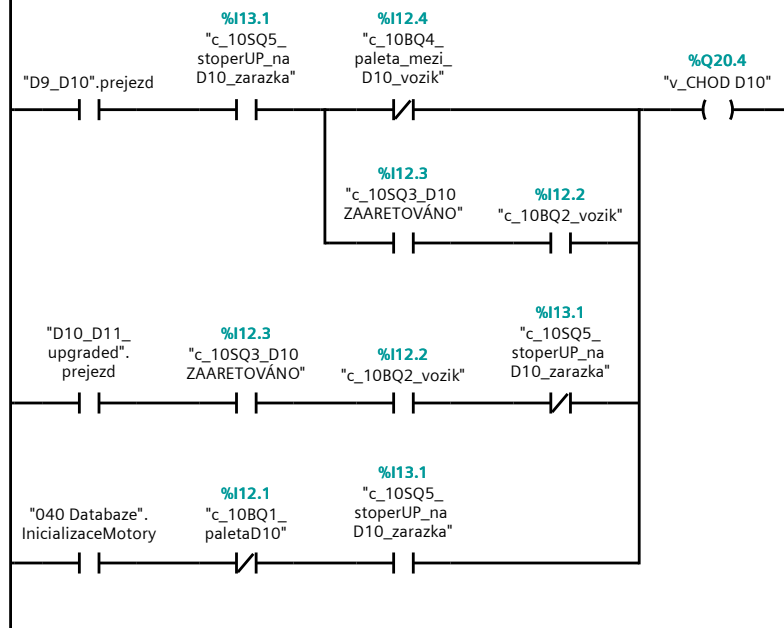

**Network 25: Setování poruchy při přejezdu - pro všechny přejezdy**

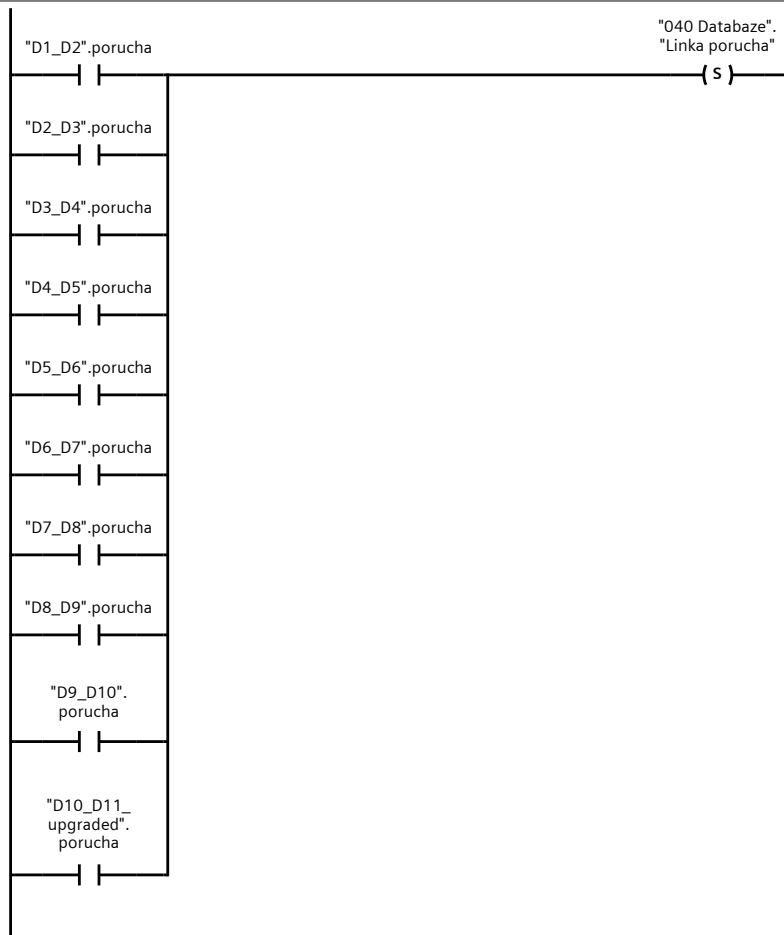

**Network 26: Zajištění vozíku-přívoz**

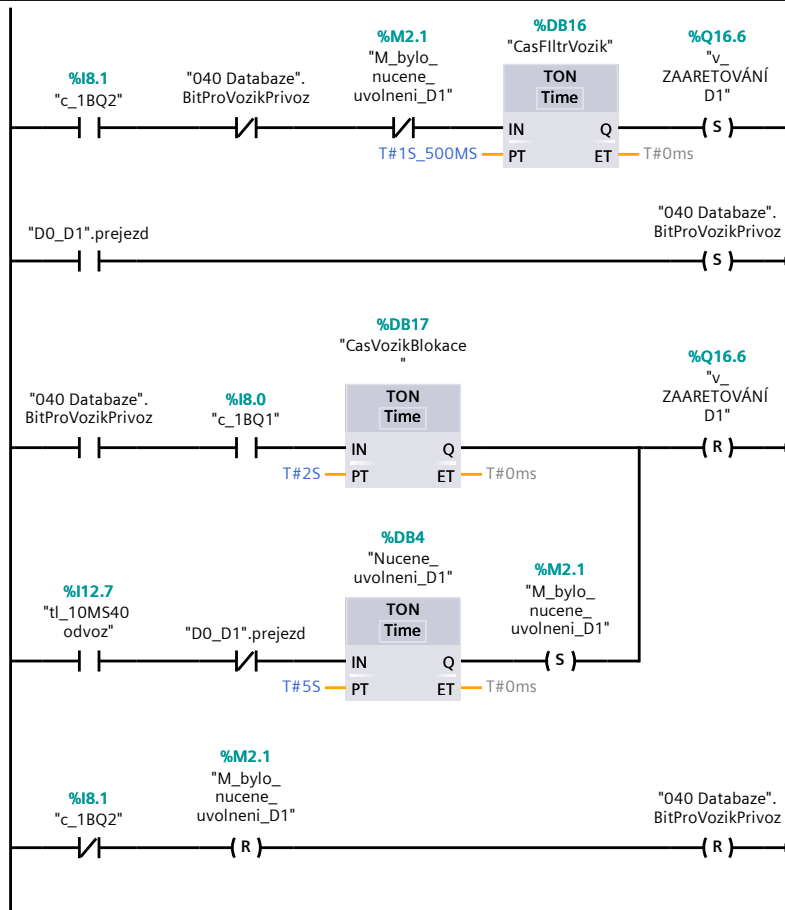

### Network 27: Zajištění vozíku-odvoz

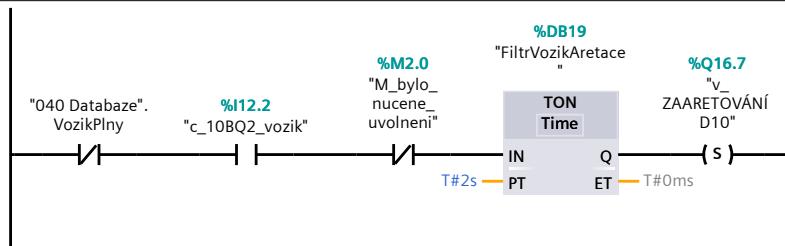

### Network 28: Odjištění vozíku odvoz

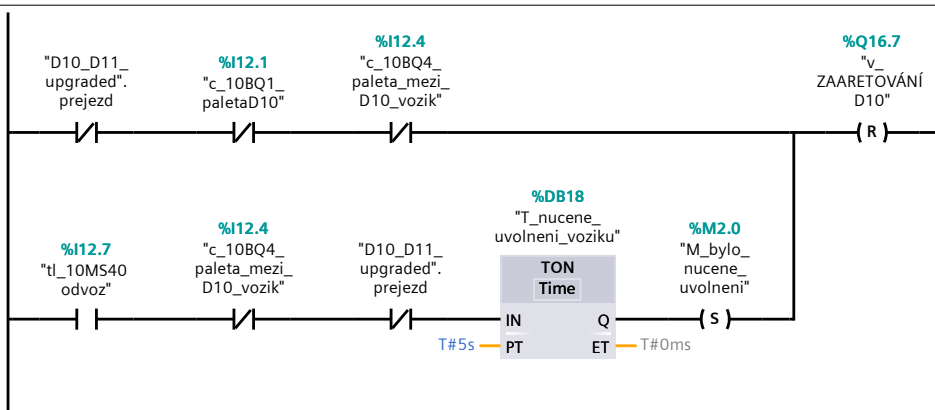

### Network 29: Pojištění proti aretaci plného vozíku u ODVOZU

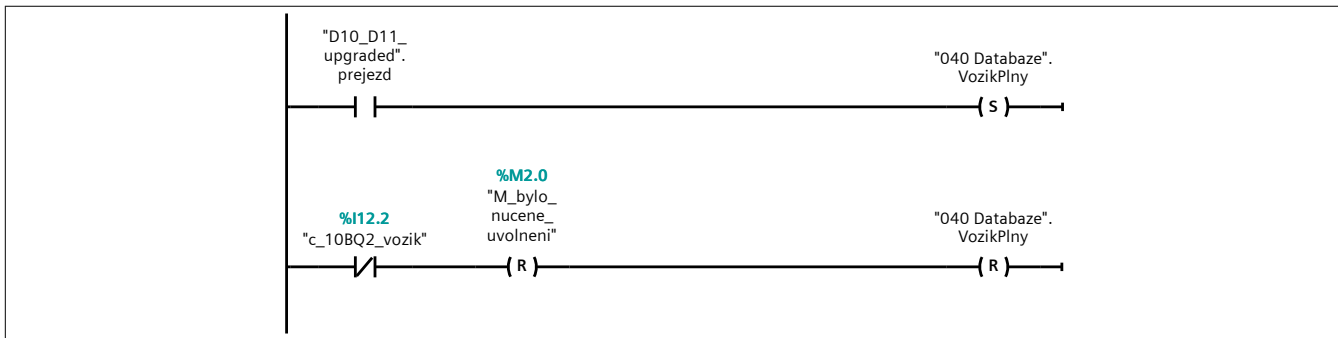

### Network 30: Blokace konec linky

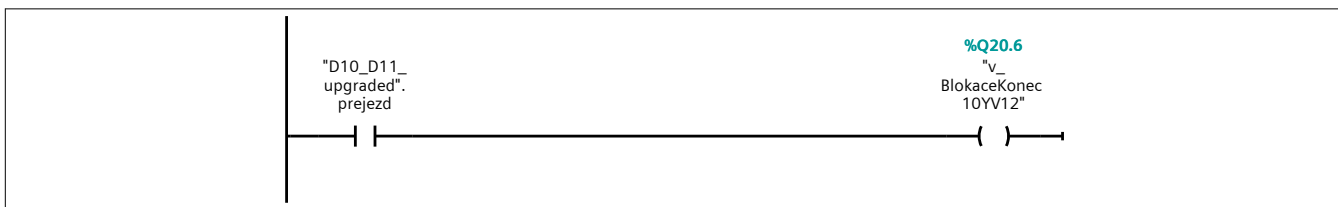

### Network 31: Blokace začátek linky

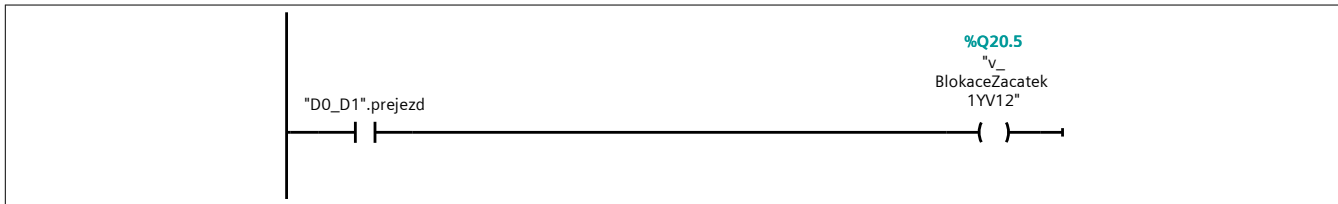

## A1-DIO/DO0 [CPU 1214C DC/DC/DC] / Program blocks

### Prejezd\_A [FB2]

#### Prejezd\_A Properties

##### General

<b>Name</b>	Prejezd_A	<b>Number</b>	2	<b>Type</b>	FB
<b>Language</b>	LAD	<b>Numbering</b>	Automatic		

##### Information

<b>Title</b>	Přejezd mezi dvěma do- pravníky	<b>Author</b>		<b>Comment</b>	
<b>Family</b>		<b>Version</b>	0.1	<b>User-defined ID</b>	

Name	Data type	Default value	Retain	Access- ible from HMI/OP C UA	Wri- ta- ble from HM I/O PC UA	Visible in HMI engi- neer- ing	Set- point	Super- vision	Comment
▼ Input									
cidlo_vychozi	Bool	false	Non-retain	True	True	True	False		
cidlo_cilovy	Bool	false	Non-retain	True	True	True	False		
potvrzeni	Bool	false	Non-retain	True	True	True	False		
PodminkaPrejez- du0	Bool	false	Non-retain	True	True	True	False		
Output									
InOut									
▼ Static									
prejezd	Bool	false	Non-retain	True	True	True	False		
▼ timeout	IEC_TIMER		Non-retain	True	True	True	False		
PT	Time	T#0ms	Non-retain	True	True	True	False		
ET	Time	T#0ms	Non-retain	True	False	True	False		
IN	Bool	false	Non-retain	True	True	True	False		
Q	Bool	false	Non-retain	True	False	True	False		
porucha	Bool	false	Non-retain	True	True	True	True		
▼ CasFiltrVychozi	IEC_TIMER		Non-retain	True	True	True	False		
PT	Time	T#0ms	Non-retain	True	True	True	False		
ET	Time	T#0ms	Non-retain	True	False	True	False		
IN	Bool	false	Non-retain	True	True	True	False		
Q	Bool	false	Non-retain	True	False	True	False		

Name	Data type	Default value	Retain	Access-ible from HMI/OP C UA	Wri-ta-ble from HM I/O PC UA	Visible in HMI engi-neer-ing	Set-point	Super- vision	Comment
▼ CasFiltrCil	IEC_TIMER		Non-retain	True	True	True	True		
PT	Time	T#0ms	Non-retain	True	True	True	False		
ET	Time	T#0ms	Non-retain	True	False	True	False		
IN	Bool	false	Non-retain	True	True	True	False		
Q	Bool	false	Non-retain	True	False	True	False		
FiltrPotvrzen	Bool	false	Non-retain	True	True	True	True		
SpinacPoruchy	Bool	false	Non-retain	True	True	True	False		
Temp									
Constant									

### Network 1:

Pokud chceme PodminkuPrejezdu vyřadit na vstup ji dáme true

Network 1:

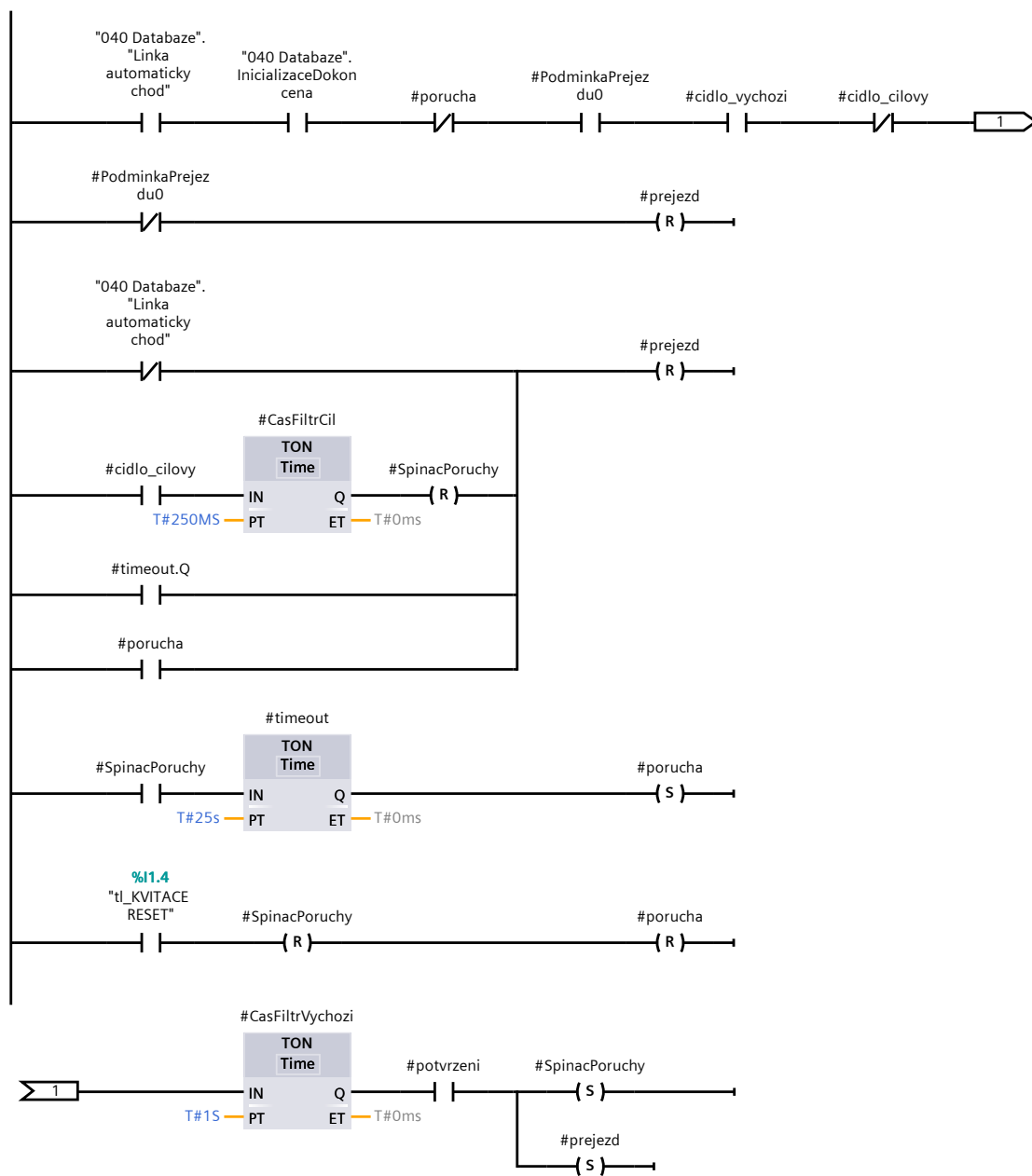

## A1-DIO/DO0 [CPU 1214C DC/DC/DC] / Program blocks

### D6\_D7 [DB2]

#### D6\_D7 Properties

##### General

<b>Name</b>	D6_D7	<b>Number</b>	2	<b>Type</b>	DB
<b>Language</b>	DB	<b>Numbering</b>	Automatic		

##### Information

<b>Title</b>		<b>Author</b>		<b>Comment</b>	
<b>Family</b>		<b>Version</b>	0.1	<b>User-defined ID</b>	

Name	Data type	Start value	Retain	Access- ible from HMI/O PC UA	Wri- ta- ble fro- m HM I/O PC UA	Visi- ble in HMI engi- neer- ing	Set- point	Super- vision	Comment
▼ Input									
cidlo_vychozi	Bool	false	False	True	True	True	False		
cidlo_cilovy	Bool	false	False	True	True	True	False		
potvrzeni	Bool	false	False	True	True	True	False		
PodminkaPrejez- du0	Bool	false	False	True	True	True	False		
Output									
InOut									
▼ Static									
prejezd	Bool	false	False	True	True	True	False		
▼ timeout	IEC_TIMER		False	True	True	True	False		
PT	Time	T#0ms	False	True	True	True	False		
ET	Time	T#0ms	False	True	False	True	False		
IN	Bool	false	False	True	True	True	False		
Q	Bool	false	False	True	False	True	False		
porucha	Bool	false	False	True	True	True	True		
▼ CasFiltrVychozi	IEC_TIMER		False	True	True	True	False		
PT	Time	T#0ms	False	True	True	True	False		
ET	Time	T#0ms	False	True	False	True	False		
IN	Bool	false	False	True	True	True	False		
Q	Bool	false	False	True	False	True	False		

Name	Data type	Start value	Retain	Access-ible from HMI/O PC UA	Wri-ta-ble from HM I/O PC UA	Visible in HMI engi-neer-ing	Set-point	Super-vision	Comment
▼ CasFiltrCil	IEC_TIMER		False	True	True	True	True		
PT	Time	T#0ms	False	True	True	True	False		
ET	Time	T#0ms	False	True	False	True	False		
IN	Bool	false	False	True	True	True	False		
Q	Bool	false	False	True	False	True	False		
FiltrPotvrzen	Bool	false	False	True	True	True	True		
SpinacPoruchy	Bool	false	False	True	True	True	False		

## A1-DIO/DO0 [CPU 1214C DC/DC/DC] / Program blocks

### D4\_D5 [DB3]

#### D4\_D5 Properties

##### General

<b>Name</b>	D4_D5	<b>Number</b>	3	<b>Type</b>	DB
<b>Language</b>	DB	<b>Numbering</b>	Automatic		

##### Information

<b>Title</b>		<b>Author</b>		<b>Comment</b>	
<b>Family</b>		<b>Version</b>	0.1	<b>User-defined ID</b>	

Name	Data type	Start value	Retain	Access- ible from HMI/O PC UA	Wri- ta- ble fro- m HM I/O PC UA	Visi- ble in HMI engi- neer- ing	Set- point	Super- vision	Comment
▼ Input									
cidlo_vychozi	Bool	false	False	True	True	True	False		
cidlo_cilovy	Bool	false	False	True	True	True	False		
potvrzeni	Bool	false	False	True	True	True	False		
PodminkaPrejez- du0	Bool	false	False	True	True	True	False		
Output									
InOut									
▼ Static									
prejezd	Bool	false	False	True	True	True	False		
▼ timeout	IEC_TIMER		False	True	True	True	False		
PT	Time	T#0ms	False	True	True	True	False		
ET	Time	T#0ms	False	True	False	True	False		
IN	Bool	false	False	True	True	True	False		
Q	Bool	false	False	True	False	True	False		
porucha	Bool	false	False	True	True	True	True		
▼ CasFiltrVychozi	IEC_TIMER		False	True	True	True	False		
PT	Time	T#0ms	False	True	True	True	False		
ET	Time	T#0ms	False	True	False	True	False		
IN	Bool	false	False	True	True	True	False		
Q	Bool	false	False	True	False	True	False		

Name	Data type	Start value	Retain	Access-ible from HMI/O PC UA	Wri-ta-ble from HM I/O PC UA	Visible in HMI engi-neer-ing	Set-point	Super-vision	Comment
▼ CasFiltrCil	IEC_TIMER		False	True	True	True	True		
PT	Time	T#0ms	False	True	True	True	False		
ET	Time	T#0ms	False	True	False	True	False		
IN	Bool	false	False	True	True	True	False		
Q	Bool	false	False	True	False	True	False		
FiltrPotvrzen	Bool	false	False	True	True	True	True		
SpinacPoruchy	Bool	false	False	True	True	True	False		

## A1-DIO/DO0 [CPU 1214C DC/DC/DC] / Program blocks

### D7\_D8 [DB6]

#### D7\_D8 Properties

##### General

<b>Name</b>	D7_D8	<b>Number</b>	6	<b>Type</b>	DB
<b>Language</b>	DB	<b>Numbering</b>	Automatic		

##### Information

<b>Title</b>		<b>Author</b>		<b>Comment</b>	
<b>Family</b>		<b>Version</b>	0.1	<b>User-defined ID</b>	

Name	Data type	Start value	Retain	Access- ible from HMI/O PC UA	Wri- ta- ble fro- m HM I/O PC UA	Visible in HMI engi- neer- ing	Set- point	Super- vision	Comment
▼ Input									
cidlo_vychozi	Bool	false	False	True	True	True	False		
cidlo_cilovy	Bool	false	False	True	True	True	False		
potvrzeni	Bool	false	False	True	True	True	False		
PodminkaPrejez- du0	Bool	false	False	True	True	True	False		
Output									
InOut									
▼ Static									
prejezd	Bool	false	False	True	True	True	False		
▼ timeout	IEC_TIMER		False	True	True	True	False		
PT	Time	T#0ms	False	True	True	True	False		
ET	Time	T#0ms	False	True	False	True	False		
IN	Bool	false	False	True	True	True	False		
Q	Bool	false	False	True	False	True	False		
porucha	Bool	false	False	True	True	True	True		
▼ CasFiltrVychozi	IEC_TIMER		False	True	True	True	False		
PT	Time	T#0ms	False	True	True	True	False		
ET	Time	T#0ms	False	True	False	True	False		
IN	Bool	false	False	True	True	True	False		
Q	Bool	false	False	True	False	True	False		

Name	Data type	Start value	Retain	Access-ible from HMI/O PC UA	Wri-ta-ble from HM I/O PC UA	Visible in HMI engi-neer-ing	Set-point	Super-vision	Comment
▼ CasFiltrCil	IEC_TIMER		False	True	True	True	True		
PT	Time	T#0ms	False	True	True	True	False		
ET	Time	T#0ms	False	True	False	True	False		
IN	Bool	false	False	True	True	True	False		
Q	Bool	false	False	True	False	True	False		
FiltrPotvrzen	Bool	false	False	True	True	True	True		
SpinacPoruchy	Bool	false	False	True	True	True	False		

## A1-DIO/DO0 [CPU 1214C DC/DC/DC] / Program blocks

### D8\_D9 [DB7]

#### D8\_D9 Properties

##### General

<b>Name</b>	D8_D9	<b>Number</b>	7	<b>Type</b>	DB
<b>Language</b>	DB	<b>Numbering</b>	Automatic		

##### Information

<b>Title</b>		<b>Author</b>		<b>Comment</b>	
<b>Family</b>		<b>Version</b>	0.1	<b>User-defined ID</b>	

Name	Data type	Start value	Retain	Access- ible from HMI/O PC UA	Wri- ta- ble fro- m HM I/O PC UA	Visible in HMI engi- neer- ing	Set- point	Super- vision	Comment
▼ Input									
cidlo_vychozi	Bool	false	False	True	True	True	False		
cidlo_cilovy	Bool	false	False	True	True	True	False		
potvrzeni	Bool	false	False	True	True	True	False		
PodminkaPrejez- du0	Bool	false	False	True	True	True	False		
Output									
InOut									
▼ Static									
prejezd	Bool	false	False	True	True	True	False		
▼ timeout	IEC_TIMER		False	True	True	True	False		
PT	Time	T#0ms	False	True	True	True	False		
ET	Time	T#0ms	False	True	False	True	False		
IN	Bool	false	False	True	True	True	False		
Q	Bool	false	False	True	False	True	False		
porucha	Bool	false	False	True	True	True	True		
▼ CasFiltrVychozi	IEC_TIMER		False	True	True	True	False		
PT	Time	T#0ms	False	True	True	True	False		
ET	Time	T#0ms	False	True	False	True	False		
IN	Bool	false	False	True	True	True	False		
Q	Bool	false	False	True	False	True	False		

Name	Data type	Start value	Retain	Access-ible from HMI/O PC UA	Wri-ta-ble from HM I/O PC UA	Visible in HMI engi-neer-ing	Set-point	Super-vision	Comment
▼ CasFiltrCil	IEC_TIMER		False	True	True	True	True		
PT	Time	T#0ms	False	True	True	True	False		
ET	Time	T#0ms	False	True	False	True	False		
IN	Bool	false	False	True	True	True	False		
Q	Bool	false	False	True	False	True	False		
FiltrPotvrzen	Bool	false	False	True	True	True	True		
SpinacPoruchy	Bool	false	False	True	True	True	False		

## A1-DIO/DO0 [CPU 1214C DC/DC/DC] / Program blocks

### D9\_D10 [DB8]

#### D9\_D10 Properties

##### General

<b>Name</b>	D9_D10	<b>Number</b>	8	<b>Type</b>	DB
<b>Language</b>	DB	<b>Numbering</b>	Automatic		

##### Information

<b>Title</b>		<b>Author</b>		<b>Comment</b>	
<b>Family</b>		<b>Version</b>	0.1	<b>User-defined ID</b>	

Name	Data type	Start value	Retain	Access- ible from HMI/O PC UA	Wri- ta- ble fro- m HM I/O PC UA	Visible in HMI engi- neer- ing	Set- point	Super- vision	Comment
▼ Input									
cidlo_vychozi	Bool	false	False	True	True	True	False		
cidlo_cilovy	Bool	false	False	True	True	True	False		
potvrzeni	Bool	false	False	True	True	True	False		
PodminkaPrejez- du0	Bool	false	False	True	True	True	False		
Output									
InOut									
▼ Static									
prejezd	Bool	false	False	True	True	True	False		
▼ timeout	IEC_TIMER		False	True	True	True	False		
PT	Time	T#0ms	False	True	True	True	False		
ET	Time	T#0ms	False	True	False	True	False		
IN	Bool	false	False	True	True	True	False		
Q	Bool	false	False	True	False	True	False		
porucha	Bool	false	False	True	True	True	True		
▼ CasFiltrVychozi	IEC_TIMER		False	True	True	True	False		
PT	Time	T#0ms	False	True	True	True	False		
ET	Time	T#0ms	False	True	False	True	False		
IN	Bool	false	False	True	True	True	False		
Q	Bool	false	False	True	False	True	False		

Name	Data type	Start value	Retain	Access-ible from HMI/O PC UA	Wri-ta-ble from HM I/O PC UA	Visible in HMI engi-neer-ing	Set-point	Super-vision	Comment
▼ CasFiltrCil	IEC_TIMER		False	True	True	True	True		
PT	Time	T#0ms	False	True	True	True	False		
ET	Time	T#0ms	False	True	False	True	False		
IN	Bool	false	False	True	True	True	False		
Q	Bool	false	False	True	False	True	False		
FiltrPotvrzen	Bool	false	False	True	True	True	True		
SpinacPoruchy	Bool	false	False	True	True	True	False		

## A1-DIO/DO0 [CPU 1214C DC/DC/DC] / Program blocks

### D5\_D6 [DB9]

#### D5\_D6 Properties

##### General

<b>Name</b>	D5_D6	<b>Number</b>	9	<b>Type</b>	DB
<b>Language</b>	DB	<b>Numbering</b>	Automatic		

##### Information

<b>Title</b>		<b>Author</b>		<b>Comment</b>	
<b>Family</b>		<b>Version</b>	0.1	<b>User-defined ID</b>	

Name	Data type	Start value	Retain	Access- ible from HMI/O PC UA	Wri- ta- ble fro- m HM I/O PC UA	Visible in HMI engi- neer- ing	Set- point	Super- vision	Comment
▼ Input									
cidlo_vychozi	Bool	false	False	True	True	True	False		
cidlo_cilovy	Bool	false	False	True	True	True	False		
potvrzeni	Bool	false	False	True	True	True	False		
PodminkaPrejez- du0	Bool	false	False	True	True	True	False		
Output									
InOut									
▼ Static									
prejezd	Bool	false	False	True	True	True	False		
▼ timeout	IEC_TIMER		False	True	True	True	False		
PT	Time	T#0ms	False	True	True	True	False		
ET	Time	T#0ms	False	True	False	True	False		
IN	Bool	false	False	True	True	True	False		
Q	Bool	false	False	True	False	True	False		
porucha	Bool	false	False	True	True	True	True		
▼ CasFiltrVychozi	IEC_TIMER		False	True	True	True	False		
PT	Time	T#0ms	False	True	True	True	False		
ET	Time	T#0ms	False	True	False	True	False		
IN	Bool	false	False	True	True	True	False		
Q	Bool	false	False	True	False	True	False		

Name	Data type	Start value	Retain	Access- sible from HMI/O PC UA	Wri- ta- ble fro m HM I/O PC UA	Visible in HMI engi- neer- ing	Set- point	Super- vision	Comment
▼ CasFiltrCil	IEC_TIMER		False	True	True	True	True		
PT	Time	T#0ms	False	True	True	True	False		
ET	Time	T#0ms	False	True	False	True	False		
IN	Bool	false	False	True	True	True	False		
Q	Bool	false	False	True	False	True	False		
FiltrPotvrzen	Bool	false	False	True	True	True	True		
SpinacPoruchy	Bool	false	False	True	True	True	False		

## A1-DIO/DO0 [CPU 1214C DC/DC/DC] / Program blocks

### D3\_D4 [DB11]

#### D3\_D4 Properties

##### General

<b>Name</b>	D3_D4	<b>Number</b>	11	<b>Type</b>	DB
<b>Language</b>	DB	<b>Numbering</b>	Automatic		

##### Information

<b>Title</b>		<b>Author</b>		<b>Comment</b>	
<b>Family</b>		<b>Version</b>	0.1	<b>User-defined ID</b>	

Name	Data type	Start value	Retain	Access- ible from HMI/O PC UA	Wri- ta- ble fro- m HM I/O PC UA	Visible in HMI engi- neer- ing	Set- point	Super- vision	Comment
▼ Input									
cidlo_vychozi	Bool	false	False	True	True	True	False		
cidlo_cilovy	Bool	false	False	True	True	True	False		
potvrzeni	Bool	false	False	True	True	True	False		
PodminkaPrejez- du0	Bool	false	False	True	True	True	False		
Output									
InOut									
▼ Static									
prejezd	Bool	false	False	True	True	True	False		
▼ timeout	IEC_TIMER		False	True	True	True	False		
PT	Time	T#0ms	False	True	True	True	False		
ET	Time	T#0ms	False	True	False	True	False		
IN	Bool	false	False	True	True	True	False		
Q	Bool	false	False	True	False	True	False		
porucha	Bool	false	False	True	True	True	True		
▼ CasFiltrVychozi	IEC_TIMER		False	True	True	True	False		
PT	Time	T#0ms	False	True	True	True	False		
ET	Time	T#0ms	False	True	False	True	False		
IN	Bool	false	False	True	True	True	False		
Q	Bool	false	False	True	False	True	False		

Name	Data type	Start value	Retain	Access-ible from HMI/O PC UA	Wri-ta-ble from HM I/O PC UA	Visible in HMI engi-neer-ing	Set-point	Super-vision	Comment
▼ CasFiltrCil	IEC_TIMER		False	True	True	True	True		
PT	Time	T#0ms	False	True	True	True	False		
ET	Time	T#0ms	False	True	False	True	False		
IN	Bool	false	False	True	True	True	False		
Q	Bool	false	False	True	False	True	False		
FiltrPotvrzen	Bool	false	False	True	True	True	True		
SpinacPoruchy	Bool	false	False	True	True	True	False		

## A1-DIO/DO0 [CPU 1214C DC/DC/DC] / Program blocks

### D2\_D3 [DB12]

#### D2\_D3 Properties

##### General

<b>Name</b>	D2_D3	<b>Number</b>	12	<b>Type</b>	DB
<b>Language</b>	DB	<b>Numbering</b>	Automatic		

##### Information

<b>Title</b>		<b>Author</b>		<b>Comment</b>	
<b>Family</b>		<b>Version</b>	0.1	<b>User-defined ID</b>	

Name	Data type	Start value	Retain	Access- ible from HMI/O PC UA	Wri- ta- ble fro- m HM I/O PC UA	Visi- ble in HMI engi- neer- ing	Set- point	Super- vision	Comment
▼ Input									
cidlo_vychozi	Bool	false	False	True	True	True	False		
cidlo_cilovy	Bool	false	False	True	True	True	False		
potvrzeni	Bool	false	False	True	True	True	False		
PodminkaPrejez- du0	Bool	false	False	True	True	True	False		
Output									
InOut									
▼ Static									
prejezd	Bool	false	False	True	True	True	False		
▼ timeout	IEC_TIMER		False	True	True	True	False		
PT	Time	T#0ms	False	True	True	True	False		
ET	Time	T#0ms	False	True	False	True	False		
IN	Bool	false	False	True	True	True	False		
Q	Bool	false	False	True	False	True	False		
porucha	Bool	false	False	True	True	True	True		
▼ CasFiltrVychozi	IEC_TIMER		False	True	True	True	False		
PT	Time	T#0ms	False	True	True	True	False		
ET	Time	T#0ms	False	True	False	True	False		
IN	Bool	false	False	True	True	True	False		
Q	Bool	false	False	True	False	True	False		

Name	Data type	Start value	Retain	Access-ible from HMI/O PC UA	Wri-ta-ble from HM I/O PC UA	Visible in HMI engi-neer-ing	Set-point	Super-vision	Comment
▼ CasFiltrCil	IEC_TIMER		False	True	True	True	True		
PT	Time	T#0ms	False	True	True	True	False		
ET	Time	T#0ms	False	True	False	True	False		
IN	Bool	false	False	True	True	True	False		
Q	Bool	false	False	True	False	True	False		
FiltrPotvrzen	Bool	false	False	True	True	True	True		
SpinacPoruchy	Bool	false	False	True	True	True	False		

## A1-DIO/DO0 [CPU 1214C DC/DC/DC] / Program blocks

### D1\_D2 [DB13]

#### D1\_D2 Properties

##### General

<b>Name</b>	D1_D2	<b>Number</b>	13	<b>Type</b>	DB
<b>Language</b>	DB	<b>Numbering</b>	Automatic		

##### Information

<b>Title</b>		<b>Author</b>		<b>Comment</b>	
<b>Family</b>		<b>Version</b>	0.1	<b>User-defined ID</b>	

Name	Data type	Start value	Retain	Access- ible from HMI/O PC UA	Wri- ta- ble fro- m HM I/O PC UA	Visi- ble in HMI engi- neer- ing	Set- point	Super- vision	Comment
▼ Input									
cidlo_vychozi	Bool	false	False	True	True	True	False		
cidlo_cilovy	Bool	false	False	True	True	True	False		
potvrzeni	Bool	false	False	True	True	True	False		
PodminkaPrejez- du0	Bool	false	False	True	True	True	False		
Output									
InOut									
▼ Static									
prejezd	Bool	false	False	True	True	True	False		
▼ timeout	IEC_TIMER		False	True	True	True	False		
PT	Time	T#0ms	False	True	True	True	False		
ET	Time	T#0ms	False	True	False	True	False		
IN	Bool	false	False	True	True	True	False		
Q	Bool	false	False	True	False	True	False		
porucha	Bool	false	False	True	True	True	True		
▼ CasFiltrVychozi	IEC_TIMER		False	True	True	True	False		
PT	Time	T#0ms	False	True	True	True	False		
ET	Time	T#0ms	False	True	False	True	False		
IN	Bool	false	False	True	True	True	False		
Q	Bool	false	False	True	False	True	False		

Name	Data type	Start value	Retain	Access- sible from HMI/O PC UA	Wri- ta- ble fro m HM I/O PC UA	Visible in HMI engi- neer- ing	Set- point	Super- vision	Comment
▼ CasFiltrCil	IEC_TIMER		False	True	True	True	True		
PT	Time	T#0ms	False	True	True	True	False		
ET	Time	T#0ms	False	True	False	True	False		
IN	Bool	false	False	True	True	True	False		
Q	Bool	false	False	True	False	True	False		
FiltrPotvrzen	Bool	false	False	True	True	True	True		
SpinacPoruchy	Bool	false	False	True	True	True	False		

## A1-DIO/DO0 [CPU 1214C DC/DC/DC] / Program blocks

### D0\_D1 [DB15]

#### D0\_D1 Properties

##### General

<b>Name</b>	D0_D1	<b>Number</b>	15	<b>Type</b>	DB
<b>Language</b>	DB	<b>Numbering</b>	Automatic		

##### Information

<b>Title</b>		<b>Author</b>		<b>Comment</b>	
<b>Family</b>		<b>Version</b>	0.1	<b>User-defined ID</b>	

Name	Data type	Start value	Retain	Access- ible from HMI/O PC UA	Wri- ta- ble fro- m HM I/O PC UA	Visible in HMI engi- neer- ing	Set- point	Super- vision	Comment
▼ Input									
cidlo_vychozi	Bool	false	False	True	True	True	False		
cidlo_cilovy	Bool	false	False	True	True	True	False		
potvrzeni	Bool	false	False	True	True	True	False		
PodminkaPrejez- du0	Bool	false	False	True	True	True	False		
Output									
InOut									
▼ Static									
prejezd	Bool	false	False	True	True	True	False		
▼ timeout	IEC_TIMER		False	True	True	True	False		
PT	Time	T#0ms	False	True	True	True	False		
ET	Time	T#0ms	False	True	False	True	False		
IN	Bool	false	False	True	True	True	False		
Q	Bool	false	False	True	False	True	False		
porucha	Bool	false	False	True	True	True	True		
▼ CasFiltrVychozi	IEC_TIMER		False	True	True	True	False		
PT	Time	T#0ms	False	True	True	True	False		
ET	Time	T#0ms	False	True	False	True	False		
IN	Bool	false	False	True	True	True	False		
Q	Bool	false	False	True	False	True	False		

Name	Data type	Start value	Retain	Access-ible from HMI/O PC UA	Wri-ta-ble from HM I/O PC UA	Visible in HMI engi-neer-ing	Set-point	Super-vision	Comment
▼ CasFiltrCil	IEC_TIMER		False	True	True	True	True		
PT	Time	T#0ms	False	True	True	True	False		
ET	Time	T#0ms	False	True	False	True	False		
IN	Bool	false	False	True	True	True	False		
Q	Bool	false	False	True	False	True	False		
FiltrPotvrzen	Bool	false	False	True	True	True	True		
SpinacPoruchy	Bool	false	False	True	True	True	False		

## A1-DIO/DO0 [CPU 1214C DC/DC/DC] / Program blocks

### Prejezd\_B [FB1]

#### Prejezd\_B Properties

##### General

<b>Name</b>	Prejezd_B	<b>Number</b>	1	<b>Type</b>	FB
<b>Language</b>	LAD	<b>Numbering</b>	Automatic		

##### Information

<b>Title</b>		<b>Author</b>		<b>Comment</b>	
<b>Family</b>		<b>Version</b>	0.1	<b>User-defined ID</b>	

Name	Data type	Default value	Retain	Access- ible from HMI/OP C UA	Wri- ta- ble from HM I/O PC UA	Visible in eng- ineer- ing	Set- point	Super- vision	Comment
▼ Input									
cidlo_vychozi	Bool	false	Non-retain	True	True	True	False		
potvrzeni	Bool	false	Non-retain	True	True	True	False		
aretaace_voziku	Bool	false	Non-retain	True	True	True	False		
stoper_na_voziku	Bool	false	Non-retain	True	True	True	False		
cidlo_prejzd	Bool	false	Non-retain	True	True	True	False		
vozik_pritomen	Bool	false	Non-retain	True	True	True	False		
Output									
InOut									
▼ Static									
prejzd	Bool	false	Non-retain	True	True	True	False		
help2	Bool	false	Non-retain	True	True	True	False		
help	Bool	false	Non-retain	True	True	True	False		
porucha	Bool	false	Non-retain	True	True	True	False		
SpinacPoruchy	Bool	false	Non-retain	True	True	True	False		
FiltrPotvrzen	Bool	false	Non-retain	True	True	True	False		
▼ CasFiltrVychoziP2	TON_TIME		Non-retain	True	True	True	True		
PT	Time	T#0ms	Non-retain	True	True	True	False		
ET	Time	T#0ms	Non-retain	True	False	True	False		
IN	Bool	false	Non-retain	True	True	True	False		

Name	Data type	Default value	Retain	Accessible from HMI/OPC UA	Writable from HM I/O PC UA	Visible in HMI engineering	Set-point	Supervision	Comment
Q	Bool	false	Non-retain	True	False	True	False		
▼ CasFiltrCilovyP2	TON_TIME		Non-retain	True	True	True	True		
PT	Time	T#0ms	Non-retain	True	True	True	False		
ET	Time	T#0ms	Non-retain	True	False	True	False		
IN	Bool	false	Non-retain	True	True	True	False		
Q	Bool	false	Non-retain	True	False	True	False		
▼ timeoutP2	TON_TIME		Non-retain	True	True	True	True		
PT	Time	T#0ms	Non-retain	True	True	True	False		
ET	Time	T#0ms	Non-retain	True	False	True	False		
IN	Bool	false	Non-retain	True	True	True	False		
Q	Bool	false	Non-retain	True	False	True	False		
podmin-ka_pro_potvrzení	Bool	false	Non-retain	True	True	True	True		
bylo_potvrzeni	Bool	false	Non-retain	True	True	True	False		
Temp									
Constant									

**Network 1:**

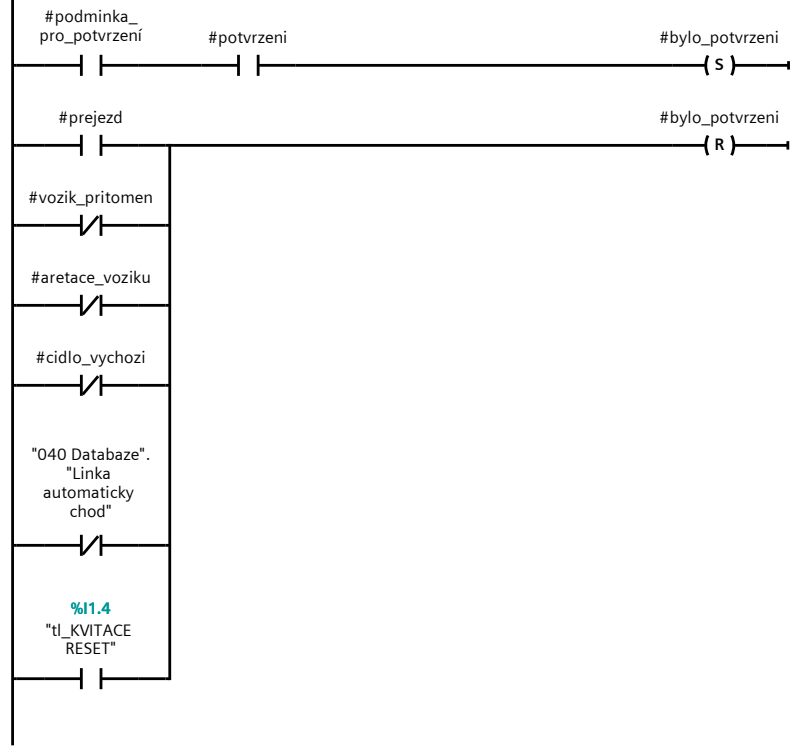

**Network 2:**

Network 2:

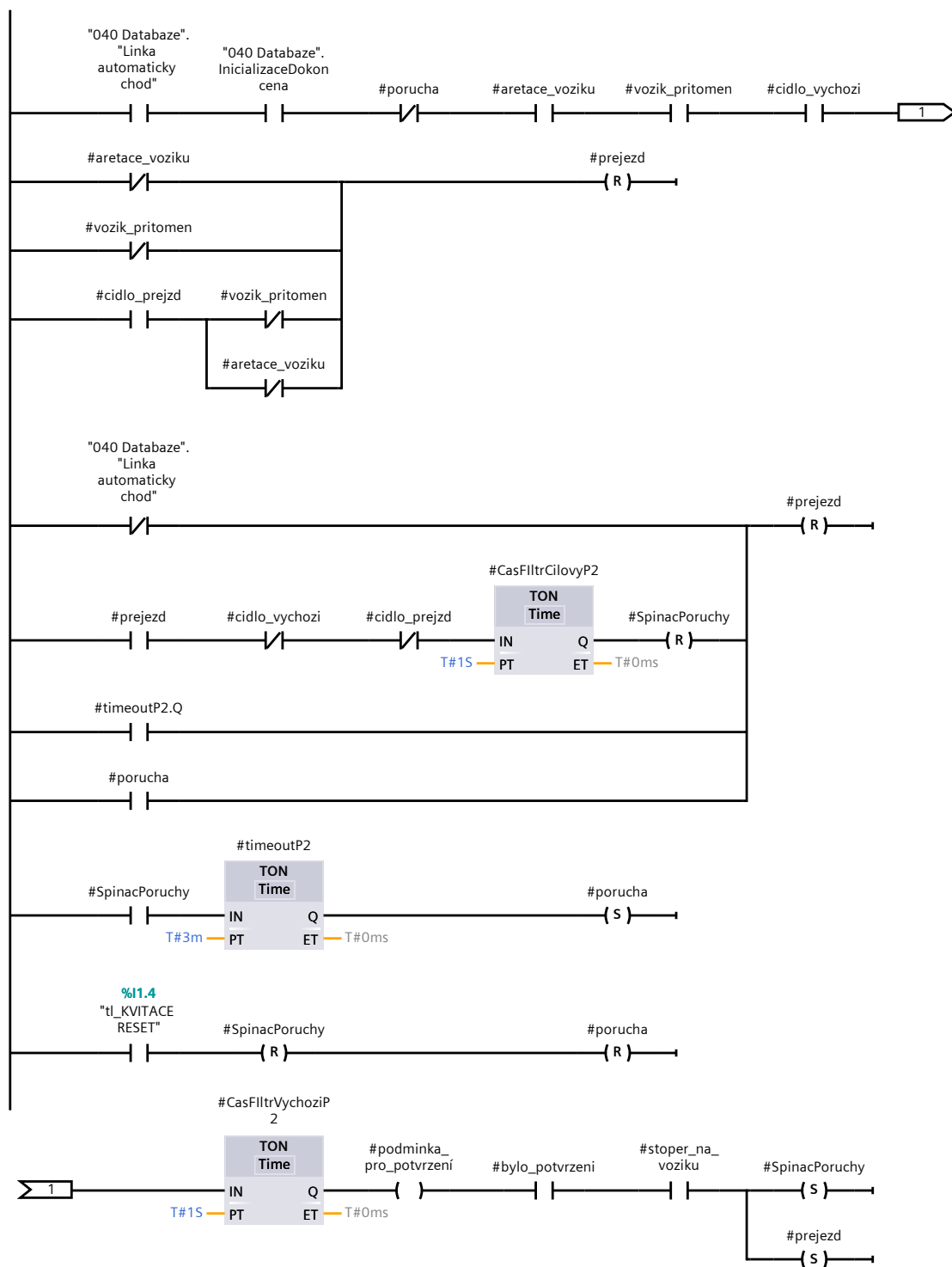

## A1-DIO/DO0 [CPU 1214C DC/DC/DC] / Program blocks

### D10\_D11\_upgraded [DB21]

#### D10\_D11\_upgraded Properties

##### General

<b>Name</b>	D10_D11_upgraded	<b>Number</b>	21	<b>Type</b>	DB
<b>Language</b>	DB	<b>Numbering</b>	Automatic		

##### Information

<b>Title</b>		<b>Author</b>		<b>Comment</b>	
<b>Family</b>		<b>Version</b>	0.1	<b>User-defined ID</b>	

Name	Data type	Start value	Retain	Access- ible from HMI/O PC UA	Wri- ta- ble fro- m HM I/O PC UA	Visible in HMI engi- neer- ing	Set- point	Super- vision	Comment
▼ Input									
cidlo_vychozi	Bool	false	False	True	True	True	False		
potvrzeni	Bool	false	False	True	True	True	False		
aretace_voziku	Bool	false	False	True	True	True	False		
stoper_na_voziku	Bool	false	False	True	True	True	False		
cidlo_prejzd	Bool	false	False	True	True	True	False		
vozik_pritomen	Bool	false	False	True	True	True	False		
Output									
InOut									
▼ Static									
prejzd	Bool	false	False	True	True	True	False		
help2	Bool	false	False	True	True	True	False		
help	Bool	false	False	True	True	True	False		
porucha	Bool	false	False	True	True	True	False		
SpinacPoruchy	Bool	false	False	True	True	True	False		
FiltrPotvrzen	Bool	false	False	True	True	True	False		
▼ CasFiltrVychoziP2	TON_TIME		False	True	True	True	True		
PT	Time	T#0ms	False	True	True	True	False		
ET	Time	T#0ms	False	True	False	True	False		
IN	Bool	false	False	True	True	True	False		

Name	Data type	Start value	Retain	Access-ible from HMI/O PC UA	Wri-ta-ble from HM I/O PC UA	Visible in HMI engi-neer-ing	Set-point	Super- vision	Comment
Q	Bool	false	False	True	False	True	False		
▼ CasFiltrCilovyP2	TON_TIME		False	True	True	True	True		
PT	Time	T#0ms	False	True	True	True	False		
ET	Time	T#0ms	False	True	False	True	False		
IN	Bool	false	False	True	True	True	False		
Q	Bool	false	False	True	False	True	False		
▼ timeoutP2	TON_TIME		False	True	True	True	True		
PT	Time	T#0ms	False	True	True	True	False		
ET	Time	T#0ms	False	True	False	True	False		
IN	Bool	false	False	True	True	True	False		
Q	Bool	false	False	True	False	True	False		
podmin-ka_pro_potvrzení	Bool	false	False	True	True	True	True		
bylo_potvrzeni	Bool	false	False	True	True	True	False		

## A1-DIO/DO0 [CPU 1214C DC/DC/DC] / Program blocks / System blocks / Program resources

### IEC\_Timer\_0\_DB [DB14]

#### IEC\_Timer\_0\_DB Properties

##### General

<b>Name</b>	IEC_Timer_0_DB	<b>Number</b>	14	<b>Type</b>	DB
<b>Language</b>	DB	<b>Numbering</b>	Automatic		

##### Information

<b>Title</b>		<b>Author</b>	Simatic	<b>Comment</b>	
<b>Family</b>	IEC	<b>Version</b>	1.0	<b>User-defined ID</b>	IEC_TMR

Name	Data type	Start value	Retain	Access- ible from HMI/O PC UA	Wri- ta- ble fro m HM I/O PC UA	Visible in HMI engi- neer- ing	Set- point	Super- vision	Comment
▼ Static									
PT	Time	T#0ms	False	True	True	True	False		
ET	Time	T#0ms	False	True	False	True	False		
IN	Bool	false	False	True	True	True	False		
Q	Bool	false	False	True	False	True	False		

## A1-DIO/DO0 [CPU 1214C DC/DC/DC] / Program blocks / System blocks / Program resources

### CasFltrVozik [DB16]

#### CasFltrVozik Properties

##### General

<b>Name</b>	CasFltrVozik	<b>Number</b>	16	<b>Type</b>	DB
<b>Language</b>	DB	<b>Numbering</b>	Automatic		

##### Information

<b>Title</b>		<b>Author</b>	Simatic	<b>Comment</b>	
<b>Family</b>	IEC	<b>Version</b>	1.0	<b>User-defined ID</b>	IEC_TMR

Name	Data type	Start value	Retain	Access- ible from HMI/O PC UA	Wri- ta- ble fro m HM I/O PC UA	Visible in HMI engi- neer- ing	Set- point	Super- vision	Comment
▼ Static									
PT	Time	T#0ms	False	True	True	True	False		
ET	Time	T#0ms	False	True	False	True	False		
IN	Bool	false	False	True	True	True	False		
Q	Bool	false	False	True	False	True	False		

## A1-DIO/DO0 [CPU 1214C DC/DC/DC] / Program blocks / System blocks / Program resources

### CasVozikBlokace [DB17]

#### CasVozikBlokace Properties

##### General

<b>Name</b>	CasVozikBlokace	<b>Number</b>	17	<b>Type</b>	DB
<b>Language</b>	DB	<b>Numbering</b>	Automatic		

##### Information

<b>Title</b>		<b>Author</b>	Simatic	<b>Comment</b>	
<b>Family</b>	IEC	<b>Version</b>	1.0	<b>User-defined ID</b>	IEC_TMR

Name	Data type	Start value	Retain	Access-ible from HMI/O PC UA	Wri-ta-ble from HM I/O PC UA	Visible in HMI engi-neer-ing	Set-point	Super-vision	Comment
▼ Static									
PT	Time	T#0ms	False	True	True	True	False		
ET	Time	T#0ms	False	True	False	True	False		
IN	Bool	false	False	True	True	True	False		
Q	Bool	false	False	True	False	True	False		

## A1-DIO/DO0 [CPU 1214C DC/DC/DC] / Program blocks / System blocks / Program resources

### FiltrVozikAretace [DB19]

#### FiltrVozikAretace Properties

##### General

<b>Name</b>	FiltrVozikAretace	<b>Number</b>	19	<b>Type</b>	DB
<b>Language</b>	DB	<b>Numbering</b>	Automatic		

##### Information

<b>Title</b>		<b>Author</b>	Simatic	<b>Comment</b>	
<b>Family</b>	IEC	<b>Version</b>	1.0	<b>User-defined ID</b>	IEC_TMR

Name	Data type	Start value	Retain	Access- ible from HMI/O PC UA	Wri- ta- ble fro m HM I/O PC UA	Visible in HMI engi- neer- ing	Set- point	Super- vision	Comment
▼ Static									
PT	Time	T#0ms	False	True	True	True	False		
ET	Time	T#0ms	False	True	False	True	False		
IN	Bool	false	False	True	True	True	False		
Q	Bool	false	False	True	False	True	False		

## A1-DIO/DO0 [CPU 1214C DC/DC/DC] / Program blocks / System blocks / Program resources

### T\_nucene\_uvolneni\_voziku [DB18]

#### T\_nucene\_uvolneni\_voziku Properties

##### General

<b>Name</b>	T_nucene_uvolneni_voziku	<b>Number</b>	18	<b>Type</b>	DB
-------------	--------------------------	---------------	----	-------------	----

<b>Language</b>	DB	<b>Numbering</b>	Automatic
-----------------	----	------------------	-----------

##### Information

<b>Title</b>		<b>Author</b>	Simatic	<b>Comment</b>	
--------------	--	---------------	---------	----------------	--

<b>Family</b>	IEC	<b>Version</b>	1.0	<b>User-defined ID</b>	IEC_TMR
---------------	-----	----------------	-----	------------------------	---------

Name	Data type	Start value	Retain	Accessible from HMI/O PC UA	Writable from HMI/O PC UA	Visible in HMI engineering	Set-point	Supervision	Comment
▼ Static									
PT	Time	T#0ms	False	True	True	True	False		
ET	Time	T#0ms	False	True	False	True	False		
IN	Bool	false	False	True	True	True	False		
Q	Bool	false	False	True	False	True	False		

## A1-DIO/DO0 [CPU 1214C DC/DC/DC] / Program blocks / System blocks / Program resources

### Nucene\_uvlneni\_D1 [DB4]

#### Nucene\_uvlneni\_D1 Properties

##### General

<b>Name</b>	Nucene_uvlneni_D1	<b>Number</b>	4	<b>Type</b>	DB
<b>Language</b>	DB	<b>Numbering</b>	Automatic		

##### Information

<b>Title</b>		<b>Author</b>	Simatic	<b>Comment</b>	
<b>Family</b>	IEC	<b>Version</b>	1.0	<b>User-defined ID</b>	IEC_TMR

Name	Data type	Start value	Retain	Access-ible from HMI/O PC UA	Wri-ta-ble from engineering	Visible in HMI	Set-point	Super-vision	Comment
▼ Static									
PT	Time	T#0ms	False	True	True	True	False		
ET	Time	T#0ms	False	True	False	True	False		
IN	Bool	false	False	True	True	True	False		
Q	Bool	false	False	True	False	True	False		



























## A1-DIO/DO0 [CPU 1214C DC/DC/DC]

### Technology objects

















This folder is empty.

## A1-DIO/DO0 [CPU 1214C DC/DC/DC] / PLC tags / Default tag table [99]

## PLC tags

PLC tags									
Name	Data type	Address	Retain	Access- ible from HMI/O PC UA	Writa- ble from HMI/O PC UA	Visi- ble in HMI engi- neer- ing	Supervision	Comment	
 s_24VDC OK	Bool	%I0.0	False	True	True	True			
 s_ZAPNUTO OK	Bool	%I0.1	False	True	True	True			
 tl_EMSTOP RM1 roz- vadec	Bool	%I0.2	False	True	True	True		výstup hardwar. tlačítka	
 tl_EMSTOP 1MS50 privoz	Bool	%I0.3	False	True	True	True		výstup hardwar. tlačítka	
 tl_EMSTOP 4MS50 kontrola	Bool	%I0.4	False	True	True	True		výstup hardwar. tlačítka	
 tl_EMSTOP 10MS50 odvoz	Bool	%I0.5	False	True	True	True		výstup hardwar. tlačítka	
 tl_EMSTOP rezerva	Bool	%I0.6	False	True	True	True		navíc (nekontrolovat)	
 s_OK PREPETOVA OCHRANA	Bool	%I0.7	False	True	True	True			
 s_OK JISTIČE POHO- NU	Bool	%I1.0	False	True	True	True		!!! jističe	
 s_OK FU POJISTKY	Bool	%I1.1	False	True	True	True		!!! pojistky	
 tl_START	Bool	%I1.2	False	True	True	True			
 tl_STOP	Bool	%I1.3	False	True	True	True			
 tl_KVITACE RESET	Bool	%I1.4	False	True	True	True			
 h_Green	Bool	%Q0.0	False	True	True	True		sloupek+kontrolka na rozvaděči	
 h_Yellow	Bool	%Q0.1	False	True	True	True		sloupek+kontrolka na rozvaděči	
 h_Red	Bool	%Q0.2	False	True	True	True		sloupek+kontrolka na rozvaděči	
 h_SIRENA	Bool	%Q0.3	False	True	True	True		zvuková signalizace	
 k_ODEŠLI 4MS40 kontrola	Bool	%Q0.4	False	True	True	True		kontrolka signalizace	
 k_BLOKUJ 4MS40 kontrola	Bool	%Q0.5	False	True	True	True		kontrolka signalizace	
 k_ODEŠLI 8MS40 vyr- azeni	Bool	%Q0.6	False	True	True	True		kontrolka signalizace	
 k_BLOKUJ 8MS40 vyrazeni	Bool	%Q0.7	False	True	True	True		kontrolka signalizace	
 k_1MS40 privoz	Bool	%Q1.0	False	True	True	True		kontrolka v bedně 1MS40(tlačítka+kontrol- ka)	
 k_10MS40 odvoz	Bool	%Q1.1	False	True	True	True		kontrolka v bedně 10MS40(tlačítka+kon- trolka)	
 c_1BQ1	Bool	%I8.0	False	True	True	True		čidlo přítomnosti D1	
 c_1BQ2	Bool	%I8.1	False	True	True	True		čidlo kontrola přítomnos- ti vozíku D (zkontrolovat)	
 c_D1 ZAARETOVÁNO	Bool	%I8.2	False	True	True	True			

Name	Data type	Address	Retain	Acces- sible from HMI/O PC UA	Writa- ble from HMI/O PC UA	Visi- ble in HMI engi- neer- ing	Supervision	Comment
tl_ODEŠLI 1MS40 pri- voz	Bool	%I8.3	False	True	True	True		
c_2BQ1	Bool	%I8.4	False	True	True	True		čidlo přítomnosti D2
c_3BQ1	Bool	%I8.5	False	True	True	True		čidlo přítomnosti D3
tl_ODESLI 4MS40 kontrola	Bool	%I8.6	False	True	True	True		
tl_BLOKUJ 4MS40 kontrola	Bool	%I8.7	False	True	True	True		
c_4BQ1	Bool	%I9.0	False	True	True	True		čidlo přítomnosti D4
c_5BQ1	Bool	%I9.1	False	True	True	True		čidlo přítomnosti D5
c_6BQ1	Bool	%I9.2	False	True	True	True		čidlo přítomnosti D6
c_7BQ1	Bool	%I9.3	False	True	True	True		čidlo přítomnosti D7
c_8BQ1	Bool	%I9.4	False	True	True	True		čidlo přítomnosti D8
c_9BQ1_paletaD9	Bool	%I12.0	False	True	True	True		čidlo přítomnosti D9, Ul- trazvuk
c_10BQ1_paletaD10	Bool	%I12.1	False	True	True	True		čidlo přítomnosti D10, Ultrazvuk
c_10BQ2_vozik	Bool	%I12.2	False	True	True	True		čidlo přítomnosti vozíku, IND
c_10SQ3_D10 ZAAR- ETOVÁNO	Bool	%I12.3	False	True	True	True		aretace vozíku aktivní, MAG čidlo na válci
c_10BQ4_paleta_me- zi_D10_vozik	Bool	%I12.4	False	True	True	True		čidlo kontrola přejetí na vozík, Ultrazvuk
tl_ODEŠLI 8MS40 vyr- azeni	Bool	%I12.5	False	True	True	True		
tl_BLOKUJ 8MS40 vyrazeni	Bool	%I12.6	False	True	True	True		
tl_10MS40 odvoz	Bool	%I12.7	False	True	True	True		
v_CHOD D1	Bool	%Q16.0	False	True	True	True		
v_CHOD D2	Bool	%Q16.1	False	True	True	True		
v_CHOD D3	Bool	%Q16.2	False	True	True	True		
v_CHOD D4	Bool	%Q16.3	False	True	True	True		
v_CHOD D5	Bool	%Q16.4	False	True	True	True		
v_ZAARETOVÁNÍ D1	Bool	%Q16.6	False	True	True	True		Zaaretování vozíku na D1
v_ZAARETOVÁNÍ D10	Bool	%Q16.7	False	True	True	True		Zaaretování vozíku na D10
v_CHOD D6	Bool	%Q20.0	False	True	True	True		
v_CHOD D7	Bool	%Q20.1	False	True	True	True		
v_CHOD D8	Bool	%Q20.2	False	True	True	True		
v_CHOD D9	Bool	%Q20.3	False	True	True	True		
v_CHOD D10	Bool	%Q20.4	False	True	True	True		
System_Byte	Byte	%MB1	False	True	True	True		
FirstScan	Bool	%M1.0	False	True	True	True		
DiagStatusUpdate	Bool	%M1.1	False	True	True	True		
AlwaysTRUE	Bool	%M1.2	False	True	True	True		
AlwaysFALSE	Bool	%M1.3	False	True	True	True		
Clock_Byte	Byte	%MBO	False	True	True	True		

Name	Data type	Address	Retain	Access- ible from HMI/O PC UA	Writa- ble from HMI/O PC UA	Visi- ble in HMI engi- neer- ing	Supervision	Comment
 Clock_10Hz	Bool	%M0.0	False	True	True	True		
 Clock_5Hz	Bool	%M0.1	False	True	True	True		
 Clock_2.5Hz	Bool	%M0.2	False	True	True	True		
 Clock_2Hz	Bool	%M0.3	False	True	True	True		
 Clock_1.25Hz	Bool	%M0.4	False	True	True	True		
 Clock_1Hz	Bool	%M0.5	False	True	True	True		
 Clock_0.625Hz	Bool	%M0.6	False	True	True	True		
 Clock_0.5Hz	Bool	%M0.7	False	True	True	True		
 v_BlokaceZacatek 1YV12	Bool	%Q20.5	False	True	True	True		
 v_BlokaceKonec 10YV12	Bool	%Q20.6	False	True	True	True		
 c_1SQ4_stoperUP_na D1_zarazka	Bool	%I13.0	False	True	True	True		mechanická blokace proti sjetí z dráhy na vstupu
 c_10SQ5_stoper- UP_na D10_zarazka	Bool	%I13.1	False	True	True	True		mechanická blokace proti sjetí z dráhy na výstupu
 c_10BQ6_BlokaceNa- Voziku	Bool	%I13.2	False	True	True	True		detekce páky na voze
 m_BlokaceKonec 10YV12	Bool	%M20.6	False	True	True	True		
 M_bylo_nu- cene_uvolneni	Bool	%M2.0	False	True	True	True		
 M_bylo_nu- cene_uvolneni_D1	Bool	%M2.1	False	True	True	True		

## A1-DIO/DO0 [CPU 1214C DC/DC/DC] / PLC tags / Default tag table [99]

### User constants

#### User constants

Name	Data type	Value	Comment
------	-----------	-------	---------

## A1-DIO/DO0 [CPU 1214C DC/DC/DC] / PLC data types

### System data types

This folder is empty.

## A1-DIO/DO0 [CPU 1214C DC/DC/DC] / Watch and force tables

## Force table

Name	Address	Display format	Force value	Comment
"c_1BQ2":P	%I8.1:P	Bool		přítomnost vozíku
"c_D1 ZAARETOVÁNO":P	%I8.2:P	Bool		zajištění vozíku
"c_D10 ZAARETOVÁNO":P	%I12.3:P	Bool		zajištění vozíku
"c_1BQ1":P	%I8.0:P	Bool		
"c_2BQ1":P	%I8.4:P	Bool		
"c_3BQ1":P	%I8.5:P	Bool		
"c_4BQ1":P	%I9.0:P	Bool		
"c_5BQ1":P	%I9.1:P	Bool		
"c_6BQ1":P	%I9.2:P	Bool		
"c_7BQ1":P	%I9.3:P	Bool		
"c_8BQ1":P	%I9.4:P	Bool		
"c_9BQ1":P	%I12.0:P	Bool		
"c_10BQ1":P	%I12.1:P	Bool		
"c_10BQ4":P	%I12.4:P	Bool		přejezd na vozík
"c_10BQ2":P	%I12.2:P	Bool		přítomnost vozíku
"v_BlokaceZacatek 1YV12":P	%Q20.5:P	Bool		blokovací zářezka
"v_BlokaceKonec 10YV12":P	%Q20.6:P	Bool		blokovací zářezka
"v_ZAARETOVÁNÍ D1":P	%Q16.6:P	Bool		zajištění vozíku
"v_ZAARETOVÁNÍ D10":P	%Q16.7:P	Bool		zajištění vozíku
"v_CHOD D1":P	%Q16.0:P	Bool		motor
"v_CHOD D2":P	%Q16.1:P	Bool		motor
"v_CHOD D3":P	%Q16.2:P	Bool		motor
"v_CHOD D4":P	%Q16.3:P	Bool		motor
"v_CHOD D5":P	%Q16.4:P	Bool		motor
"v_CHOD D6":P	%Q20.0:P	Bool		motor
"v_CHOD D7":P	%Q20.1:P	Bool		motor
"v_CHOD D8":P	%Q20.2:P	Bool		motor
"v_CHOD D9":P	%Q20.3:P	Bool		motor
"v_CHOD D10":P	%Q20.4:P	Bool		motor
"tl_ODEŠLI 1MS40 privoz":P	%I8.3:P	Bool		tlačítko na přívozu
"tl_ODESLI 4MS40 kontrola":P	%I8.6:P	Bool		tlačítko na kontrole odesli
"tl_BLOKUJ 4MS40 kontrola":P	%I8.7:P	Bool		tlačítko na kontrole blokuj
"tl_ODEŠLI 8MS40 vyrazení":P	%I12.5:P	Bool		tlačítko na vyrazení odesli
"tl_BLOKUJ 8MS40 vyrazení":P	%I12.6:P	Bool		tlačítko na vyrazení blokuj
"tl_10MS40 odvoz":P	%I12.7:P	Bool		tlačítko na odvozu přívolej
"k_1MS40 privoz":P	%Q1.0:P	Bool		Prosvícení tlačítka
"k_ODEŠLI 4MS40 kontrola":P	%Q0.4:P	Bool		Prosvícení tlačítka
"k_BLOKUJ 4MS40 kontrola":P	%Q0.5:P	Bool		Prosvícení tlačítka
"k_ODEŠLI 8MS40 vyrazení":P	%Q0.6:P	Bool		Prosvícení tlačítka
"k_BLOKUJ 8MS40 vyrazení":P	%Q0.7:P	Bool		Prosvícení tlačítka

Name	Address	Display format	Force value	Comment
"k_10MS40 odvoz":P	%Q1.1:P	Bool		Prosvícení tlačítka
"h_SIRENA":P	%Q0.3:P	Bool		Sign sloupek
"h_Red":P	%Q0.2:P	Bool		Sign sloupek
"h_Green":P	%Q0.0:P	Bool		Sign sloupek
"h_Yellow":P	%Q0.1:P	Bool		Sign sloupek
"Automat".Stav1		Bool		Sign sloupek
"tl_START":P	%I1.2:P	Bool		
"tl_STOP":P	%I1.3:P	Bool		
"tl_KVITACE RESET":P	%I1.4:P	Bool		
"c_BlokaceKonecLinky":P	%I13.1:P	Bool		
"c_BlokaceZacatekLinky":P	%I13.0:P	Bool		
"v_ZAARETOVÁNÍ D10":P	%Q16.7:P	Bool	FALSE	

## A1-DIO/DO0 [CPU 1214C DC/DC/DC] / Watch and force tables

## Watch table\_1

Name	Address	Display format	Modify value	Comment
"c_1BQ2"	%I8.1	Bool		přítomnost vozíku
"m_BlokaceKonec 10YV12"	%M20.6	Bool		
"c_D1 ZAARETOVÁNO"	%I8.2	Bool		zajištění vozíku
"c_D10 ZAARETOVÁNO"	%I12.3	Bool		zajištění vozíku
"c_1BQ1"	%I8.0	Bool		
"c_2BQ1"	%I8.4	Bool		
"c_3BQ1"	%I8.5	Bool		
"c_4BQ1"	%I9.0	Bool		
"c_5BQ1"	%I9.1	Bool		
"c_6BQ1"	%I9.2	Bool		
"c_7BQ1"	%I9.3	Bool		
"c_8BQ1"	%I9.4	Bool		
"c_9BQ1"	%I12.0	Bool		
"c_10BQ1"	%I12.1	Bool		
"c_10BQ4"	%I12.4	Bool		přejezd na vozík
"c_10BQ2"	%I12.2	Bool		přítomnost vozíku
"v_BlokaceZacatek 1YV12"	%Q20.5	Bool		blokovací zářezka
"v_BlokaceKonec 10YV12"	%Q20.6	Bool		blokovací zářezka
"v_ZAARETOVÁNÍ D1"	%Q16.6	Bool		zajištění vozíku
"v_ZAARETOVÁNÍ D10"	%Q16.7	Bool		zajištění vozíku
"v_CHOD D1"	%Q16.0	Bool	TRUE	motor
"v_CHOD D2"	%Q16.1	Bool		motor
"v_CHOD D3"	%Q16.2	Bool		motor
"v_CHOD D4"	%Q16.3	Bool		motor
"v_CHOD D5"	%Q16.4	Bool		motor
"v_CHOD D6"	%Q20.0	Bool		motor
"v_CHOD D7"	%Q20.1	Bool		motor
"v_CHOD D8"	%Q20.2	Bool		motor
"v_CHOD D9"	%Q20.3	Bool		motor
"v_CHOD D10"	%Q20.4	Bool		motor
"tl_ODEŠLI 1MS40 pri- voz"	%I8.3	Bool		tlačítko na přívozu
"tl_ODESLI 4MS40 kon- trole"	%I8.6	Bool		tlačítko na kontrole ode- sli
"tl_BLOKUJ 4MS40 kon- trole"	%I8.7	Bool		tlačítko na kontrole blo- kuj
"tl_ODEŠLI 8MS40 vyra- zeni"	%I12.5	Bool		tlačítko na vyrazení ode- sli
"tl_BLOKUJ 8MS40 vyra- zeni"	%I12.6	Bool		tlačítko na vyrazení blo- kuj
"tl_10MS40 odvoz"	%I12.7	Bool		tlačítko na odvozu přivo- lej
"k_1MS40 privoz"	%Q1.0	Bool		Prosvícení tlačítka
"k_ODEŠLI 4MS40 kon- trole"	%Q0.4	Bool		Prosvícení tlačítka
"k_BLOKUJ 4MS40 kon- trole"	%Q0.5	Bool		Prosvícení tlačítka
"k_ODEŠLI 8MS40 vyra- zeni"	%Q0.6	Bool		Prosvícení tlačítka

Name	Address	Display format	Modify value	Comment
"k_BLOKUJ 8MS40 vyra- zeni"	%Q0.7	Bool		Prosvícení tlačítka
"k_10MS40 odvoz"	%Q1.1	Bool		Prosvícení tlačítka
"h_SIRENA"	%Q0.3	Bool		Sign sloupek
"h_Red"	%Q0.2	Bool		Sign sloupek
"h_Green"	%Q0.0	Bool		Sign sloupek
"h_Yellow"	%Q0.1	Bool		Sign sloupek
"Prejezdy".PrejezdZakaz		Bool		Sign sloupek
"Prejezdy".Stav0		Bool		
"Prejezdy".Stav1		Bool		
"Prejezdy".Stav2		Bool		
"Prejezdy".Stav3		Bool		
"Prejezdy".Stav4		Bool		
"Prejezdy".StavZakaz		Bool		
"c_BlokaceKonecLinky"	%I13.1	Bool		
"c_BlokaceZacatekLinky"	%I13.0	Bool		
"c_BlokaceNaVoziku"	%I13.2	Bool		

## A1-DIO/DO0 [CPU 1214C DC/DC/DC]

### PLC alarm text lists

This folder is empty.

## A1-DIO/DO0 [CPU 1214C DC/DC/DC] / Local modules

### A1-DIO/DO0 [CPU 1214C DC/DC/DC]

A1-DIO/DO0			
General\Project information			
Name	A1-DIO/DO0	Author	Michal Lorenc
Comment		Slot	1
Rack	0		
General\Catalog information			
Short designation	CPU 1214C DC/DC/DC	Description	Work memory 75 KB; 24VDC power supply with DI14 x 24VDC SINK/ SOURCE, DQ10 x 24VDC and AI2 on board; 6 high-speed counters and 4 pulse outputs on board; signal board expands on-board I/O; up to 3 communication modules for serial communication; up to 8 signal modules for I/O expansion; 0.04 ms/1000 instructions; PROFINET interface for programming, HMI and PLC-to-PLC communication
Article number	6ES7 214-1AG31-0XB0	Firmware version	V3.0
PROFINET interface\General\Project information			
Name	PROFINET interface_1	Comment	
Name	DI 14/DQ 10_1	Comment	
Name	AI 2_1	Comment	
PROFINET interface\Ethernet addresses\Interface networked with			
Subnet:	PN/IE_1		
PROFINET interface\Ethernet addresses\IP protocol			
IP configuration	Set IP address in the project	IP address:	192.168.0.1
Subnet mask:	255.255.255.0	Use router	False
PROFINET interface\Ethernet addresses\PROFINET			
PROFINET device name is set directly at the device	False	Generate PROFINET device name automatically	True
PROFINET device name:	a1-dio/do0	Converted name:	a1-dioxrdo05d4a
Device number:	0		
PROFINET interface\Digital inputs\Input filters			
I0.0 - I0.3	6.40ms	I0.4 - I0.7	6.40ms
I1.0 - I1.3	6.40ms	I1.4 - I1.7	6.40ms
PROFINET interface\Digital inputs\Channel0			
Channel address	I0.0	Enable rising edge detection	0
Enable falling edge detection	0	Enable pulse catch	0
PROFINET interface\Digital inputs\Channel1			
Channel address	I0.1	Enable rising edge detection	0
Enable falling edge detection	0	Enable pulse catch	0
PROFINET interface\Digital inputs\Channel2			
Channel address	I0.2	Enable rising edge detection	0
Enable falling edge detection	0	Enable pulse catch	0
PROFINET interface\Digital inputs\Channel3			
Channel address	I0.3	Enable rising edge detection	0

Totally Integrated Automation Portal			
Enable falling edge detection	0	Enable pulse catch	0
PROFINET interface\Digital inputs\Channel4			
Channel address	I0.4	Enable rising edge detection	0
Enable falling edge detection	0	Enable pulse catch	0
PROFINET interface\Digital inputs\Channel5			
Channel address	I0.5	Enable rising edge detection	0
Enable falling edge detection	0	Enable pulse catch	0
PROFINET interface\Digital inputs\Channel6			
Channel address	I0.6	Enable rising edge detection	0
Enable falling edge detection	0	Enable pulse catch	0
PROFINET interface\Digital inputs\Channel7			
Channel address	I0.7	Enable rising edge detection	0
Enable falling edge detection	0	Enable pulse catch	0
PROFINET interface\Digital inputs\Channel8			
Channel address	I1.0	Enable rising edge detection	0
Enable falling edge detection	0	Enable pulse catch	0
PROFINET interface\Digital inputs\Channel9			
Channel address	I1.1	Enable rising edge detection	0
Enable falling edge detection	0	Enable pulse catch	0
PROFINET interface\Digital inputs\Channel10			
Channel address	I1.2	Enable rising edge detection	0
Enable falling edge detection	0	Enable pulse catch	0
PROFINET interface\Digital inputs\Channel11			
Channel address	I1.3	Enable rising edge detection	0
Enable falling edge detection	0	Enable pulse catch	0
PROFINET interface\Digital inputs\Channel12			
Channel address	I1.4	Enable pulse catch	0
PROFINET interface\Digital inputs\Channel13			
Channel address	I1.5	Enable pulse catch	0
PROFINET interface\Advanced options\Interface options			
Support device replacement without exchangeable medium	True	Use IEC V2.2 LLDP mode	True
PROFINET interface\Advanced options\Anchor (ParameterRealtimeSettingsMenu)			
The TreeNode ParameterRealtimeSettingsMenu was not filled by some ACF			
PROFINET interface\Advanced options\Port [X1 P1]\General\Project information			
Name	Port_1	Comment	
PROFINET interface\Advanced options\Port [X1 P1]\Port interconnection\Local port:			
Local port:	A1-DIO/DO0\PROFINET interface_1 [X1]\Port_1 [X1 P1]	Medium:	Copper

Totally Integrated Automation Portal			
Cable name: ---			
			
<b>PROFINET interface\Advanced options\Port [X1 P1]\Port interconnection\Partner port:</b>			
	Monitoring of partner port is not possible	<b>Partner port:</b>	Any partner
<b>PROFINET interface\Advanced options\Port [X1 P1]\Port options\Activate</b>			
<b>Activate this port for use</b>	True		
<b>PROFINET interface\Advanced options\Port [X1 P1]\Port options\Connection</b>			
<b>Transmission rate / duplex:</b>	Automatic	<b>Monitor</b>	False
<b>Enable autonegotiation</b>	True		
<b>PROFINET interface\Advanced options\Port [X1 P1]\Port options\Boundaries</b>			
<b>End of detection of accessible devices</b>	False	<b>End of topology discovery</b>	False
<b>End of the sync domain</b>	False		
<b>PROFINET interface\Analog inputs\Noise reduction</b>			
<b>Integration time</b>	50 Hz (20 ms)		
<b>PROFINET interface\Analog inputs\Channel0</b>			
<b>Channel address</b>	IW64	<b>Measurement type</b>	Voltage
<b>Voltage range</b>	0..10 V	<b>Smoothing</b>	Weak (4 cycles)
<b>Empty</b>		<b>Enable overflow diagnostics</b>	1
<b>PROFINET interface\Analog inputs\Channel1</b>			
<b>Channel address</b>	IW66	<b>Measurement type</b>	Voltage
<b>Voltage range</b>	0..10 V	<b>Smoothing</b>	Weak (4 cycles)
<b>Empty</b>		<b>Enable overflow diagnostics</b>	1
<b>PROFINET interface\Digital outputs</b>			
<b>Reaction to CPU STOP</b>	Use substitute value		
<b>PROFINET interface\Digital outputs\Channel0</b>			
<b>Channel address</b>	Q0.0	<b>Substitute a value of 1 on a change from RUN to STOP.</b>	0
<b>PROFINET interface\Digital outputs\Channel1</b>			
<b>Channel address</b>	Q0.1	<b>Substitute a value of 1 on a change from RUN to STOP.</b>	0
<b>PROFINET interface\Digital outputs\Channel2</b>			
<b>Channel address</b>	Q0.2	<b>Substitute a value of 1 on a change from RUN to STOP.</b>	0
<b>PROFINET interface\Digital outputs\Channel3</b>			
<b>Channel address</b>	Q0.3	<b>Substitute a value of 1 on a change from RUN to STOP.</b>	0
<b>PROFINET interface\Digital outputs\Channel4</b>			
<b>Channel address</b>	Q0.4	<b>Substitute a value of 1 on a change from RUN to STOP.</b>	0

Totally Integrated Automation Portal			
<b>PROFINET interface\Digital outputs\Channel5</b>			
Channel address	Q0.5	Substitute a value of 1 on a change from RUN to STOP.	0
<b>PROFINET interface\Digital outputs\Channel6</b>			
Channel address	Q0.6	Substitute a value of 1 on a change from RUN to STOP.	0
<b>PROFINET interface\Digital outputs\Channel7</b>			
Channel address	Q0.7	Substitute a value of 1 on a change from RUN to STOP.	0
<b>PROFINET interface\Digital outputs\Channel8</b>			
Channel address	Q1.0	Substitute a value of 1 on a change from RUN to STOP.	0
<b>PROFINET interface\Digital outputs\Channel9</b>			
Channel address	Q1.1	Substitute a value of 1 on a change from RUN to STOP.	0
<b>PROFINET interface\Time synchronization</b>			
Enable time synchronization via NTP server	Enable time synchronization via NTP server		IP addresses
Server 1	0.0.0.0	Server 2	0.0.0.0
Server 3	0.0.0.0	Server 4	0.0.0.0
Update interval	10sec		
<b>PROFINET interface\I/O addresses\Input addresses</b>			
Start address	0.0	End address	1.7
Process image	Cyclic PI		
<b>PROFINET interface\I/O addresses\Input addresses</b>			
Start address	64	End address	67
Process image	Cyclic PI		
<b>PROFINET interface\I/O addresses\Output addresses</b>			
Start address	0.0	End address	1.7
Process image	Cyclic PI		
<b>High speed counters (HSC)\HSC1\General\Enable</b>			
Enable this high speed counter	0	Enable this high speed counter	0
Enable this high speed counter	0	Enable this high speed counter	0
Enable this high speed counter	0	Enable this high speed counter	0
<b>High speed counters (HSC)\HSC1\General\Project information</b>			
Name	HSC_1	Comment	
Name	HSC_2	Comment	
Name	HSC_3	Comment	
Name	HSC_4	Comment	
Name	HSC_5	Comment	
Name	HSC_6	Comment	
<b>High speed counters (HSC)\HSC1\I/O addresses\Input addresses</b>			
Start address	1000.0	End address	1003.7
Start address	1004.0	End address	1007.7
Process image	Cyclic PI	Start address	1008.0
End address	1011.7	Process image	Cyclic PI
Start address	1012.0	End address	1015.7
Process image	Cyclic PI	Start address	1016.0
End address	1019.7	Process image	Cyclic PI
Start address	1020.0	End address	1023.7
Process image	Cyclic PI	Process image	Cyclic PI

Totally Integrated Automation Portal					
<b>Pulse generators (PTO/PWM)\PTO1/PWM1\General\Enable</b>					
Enable this pulse generator	0	Enable this pulse generator	0		
<b>Pulse generators (PTO/PWM)\PTO1/PWM1\General\Project information</b>					
Name	Pulse_1	Comment			
Name	Pulse_2	Comment			
<b>Pulse generators (PTO/PWM)\PTO1/PWM1\I/O addresses\Output addresses</b>					
Start address	1000.0	End address	1001.7		
Start address	1002.0	End address	1003.7		
Process image	Cyclic PI	Process image	Cyclic PI		
<b>Startup</b>					
Startup after POWER ON	Warm restart - mode before POWER OFF	Comparison preset to actual configuration	Startup CPU even if mismatch		
Configuration time	60000ms				
<b>Cycle</b>					
Cycle monitoring time	150ms				
Enable minimum cycle time for cyclic OBs	0	Minimum cycle time	1ms		
<b>Communication load</b>					
Cycle load due to communication	20%				
<b>System and clock memory\System memory bits</b>					
Enable the use of system memory byte	1	Address of system memory byte (MBx)	1		
First cycle	%M1.0 (FirstScan)	Diagnostic status changed	%M1.1 (DiagStatusUpdate)		
Always 1 (high)	%M1.2 (AlwaysTRUE)	Always 0 (low)	%M1.3 (AlwaysFALSE)		
<b>System and clock memory\Clock memory bits</b>					
Enable the use of clock memory byte	1	Address of clock memory byte (MBx)	0		
10 Hz clock	%M0.0 (Clock_10Hz)	5 Hz clock	%M0.1 (Clock_5Hz)		
2.5 Hz clock	%M0.2 (Clock_2.5Hz)	2 Hz clock	%M0.3 (Clock_2Hz)		
1.25 Hz clock	%M0.4 (Clock_1.25Hz)	1 Hz clock	%M0.5 (Clock_1Hz)		
0.625 Hz clock	%M0.6 (Clock_0.625Hz)	0.5 Hz clock	%M0.7 (Clock_0.5Hz)		
<b>Web server\General</b>					
Activate web server on this module	False	Permit access only with HTTPS	False		
<b>Web server\Automatic update</b>					
Enable automatic update	True	Update interval	0s		
<b>Web server\User-defined web pages</b>					
Application name	HTML source path	Default HTML page	Files with dynamic content	Web DB number	Fragment DB number
		index.htm	.htm;.html	333	334
<b>Overview of addresses\Overview of addresses\Overview of addresses</b>					
Inputs	True	Outputs	True		
Address gaps	False	Slot	True		

Type	Addr. from	Addr. to	Module	PIP	Device name	Device number	Size	Master / IO system	Rack	Slot
I	0	1	DI 14/DQ 10_1	-	A1-DIO/DO0 [CPU 1214C DC/DC/DC]	-	2 Bytes	-	0	1 1
O	0	1	DI 14/DQ 10_1	-	A1-DIO/DO0 [CPU 1214C DC/DC/DC]	-	2 Bytes	-	0	1 1
I	64	67	AI 2_1	-	A1-DIO/DO0 [CPU 1214C DC/DC/DC]	-	4 Bytes	-	0	1 2
I	1000	1003	HSC_1	-	A1-DIO/DO0 [CPU 1214C DC/DC/DC]	-	4 Bytes	-	0	1 16
I	1004	1007	HSC_2	-	A1-DIO/DO0 [CPU 1214C DC/DC/DC]	-	4 Bytes	-	0	1 17
I	1008	1011	HSC_3	-	A1-DIO/DO0 [CPU 1214C DC/DC/DC]	-	4 Bytes	-	0	1 18
I	1012	1015	HSC_4	-	A1-DIO/DO0 [CPU 1214C DC/DC/DC]	-	4 Bytes	-	0	1 19
I	1016	1019	HSC_5	-	A1-DIO/DO0 [CPU 1214C DC/DC/DC]	-	4 Bytes	-	0	1 20
I	1020	1023	HSC_6	-	A1-DIO/DO0 [CPU 1214C DC/DC/DC]	-	4 Bytes	-	0	1 21
O	1000	1001	Pulse_1	-	A1-DIO/DO0 [CPU 1214C DC/DC/DC]	-	2 Bytes	-	0	1 32
O	1002	1003	Pulse_2	-	A1-DIO/DO0 [CPU 1214C DC/DC/DC]	-	2 Bytes	-	0	1 33
O	1004	1005	Pulse_3	-	A1-DIO/DO0 [CPU 1214C DC/DC/DC]	-	2 Bytes	-	0	1 34
O	1006	1007	Pulse_4	-	A1-DIO/DO0	-	2 Bytes	-	0	1 35

Type	Addr. from	Addr. to	Module	PIP	Device name	Device number	Size	Master / IO system	Rack	Slot
					[CPU 1214C DC/DC/DC]					
I	8	9	A1-DI1	-	A1-DIO/DO0 [CPU 1214C DC/DC/DC]	-	2 Bytes	-	0	2
I	12	13	A-DI2	-	A1-DIO/DO0 [CPU 1214C DC/DC/DC]	-	2 Bytes	-	0	3
O	16	16	A1-DO1	-	A1-DIO/DO0 [CPU 1214C DC/DC/DC]	-	1 Bytes	-	0	4
O	20	20	A1-DO2	-	A1-DIO/DO0 [CPU 1214C DC/DC/DC]	-	1 Bytes	-	0	5

**Time of day\Local time**

**Time zone** (UTC +01:00) Berlin, Bern, Brussels, Rome, Stockholm, Vienna

**Time of day\Daylight saving time**

**Activate daylight saving time** 0 **Difference between standard and daylight saving time** 60mins

**Time of day\Daylight saving time\Start of daylight saving time**

**Starting week of the month:** Last **of** March **at** 01:00 a.m. **Sunday**

**Time of day\Daylight saving time\Start of standard time**

**of** Last **at** 02:00 a.m. **Sunday**

**Protection\**

**Level of protection** No protection

**Protection\Password for read/write access**

**Password** **Confirm password**

**Connection resources**

**PG communication:** 1 **OP communication:** 1

**S7 basic communication:** 0 **S7 communication:** 0

**Maximum number of S7 connection resources:** 32

**Maximum number of S7 connection resources:** 32

**Maximum number of S7 connection resources:** 32

**Maximum number of S7 connection resources:** 32

**Anchor (AddressesOverviewMenu)**

The AddressesOverviewMenu was not filled by some ACF

## A1-DIO/DO0 [CPU 1214C DC/DC/DC] / Local modules

### A1-DI1

A1-DI1			
General\Project information			
Name	A1-DI1	Author	Michal Lorenc
Comment		Slot	2
General\Catalog information			
Short designation	SM 1221 DI16 x 24VDC	Description	Digital input module DI16 x 24VDC SINK/SOURCE; configurable input delay; plug-in terminal blocks
Article number	6ES7 221-1BH32-0XB0	Firmware version	V2.0
DI 16\Project information			
Name	A1-DI1	Comment	
DI 16\Digital inputs\Input filters			
I8.0 - I8.3	6.40ms	I8.4 - I8.7	6.40ms
I9.0 - I9.3	6.40ms	I9.4 - I9.7	6.40ms
DI 16\Digital inputs\Channel0			
Channel address	I8.0		
DI 16\Digital inputs\Channel1			
Channel address	I8.1		
DI 16\Digital inputs\Channel2			
Channel address	I8.2		
DI 16\Digital inputs\Channel3			
Channel address	I8.3		
DI 16\Digital inputs\Channel4			
Channel address	I8.4		
DI 16\Digital inputs\Channel5			
Channel address	I8.5		
DI 16\Digital inputs\Channel6			
Channel address	I8.6		
DI 16\Digital inputs\Channel7			
Channel address	I8.7		
DI 16\Digital inputs\Channel8			
Channel address	I9.0		
DI 16\Digital inputs\Channel9			
Channel address	I9.1		
DI 16\Digital inputs\Channel10			
Channel address	I9.2		
DI 16\Digital inputs\Channel11			
Channel address	I9.3		
DI 16\Digital inputs\Channel12			
Channel address	I9.4		
DI 16\Digital inputs\Channel13			
Channel address	I9.5		
DI 16\Digital inputs\Channel14			
Channel address	I9.6		
DI 16\Digital inputs\Channel15			
Channel address	I9.7		
DI 16\I/O addresses\Input addresses			
Start address	8.0	End address	9.7
Process image	Cyclic PI		

## A1-DIO/DO0 [CPU 1214C DC/DC/DC] / Local modules

### A-DI2

A-DI2			
General\Project information			
Name	A-DI2	Author	Michal Lorenc
Comment		Slot	3
General\Catalog information			
Short designation	SM 1221 DI16 x 24VDC	Description	Digital input module DI16 x 24VDC SINK/SOURCE; configurable input delay; plug-in terminal blocks
Article number	6ES7 221-1BH32-0XB0	Firmware version	V2.0
DI 16\Project information			
Name	A-DI2	Comment	
DI 16\Digital inputs\Input filters			
I12.0 - I12.3	6.40ms	I12.4 - I12.7	6.40ms
I13.0 - I13.3	6.40ms	I13.4 - I13.7	6.40ms
DI 16\Digital inputs\Channel0			
Channel address	I12.0		
DI 16\Digital inputs\Channel1			
Channel address	I12.1		
DI 16\Digital inputs\Channel2			
Channel address	I12.2		
DI 16\Digital inputs\Channel3			
Channel address	I12.3		
DI 16\Digital inputs\Channel4			
Channel address	I12.4		
DI 16\Digital inputs\Channel5			
Channel address	I12.5		
DI 16\Digital inputs\Channel6			
Channel address	I12.6		
DI 16\Digital inputs\Channel7			
Channel address	I12.7		
DI 16\Digital inputs\Channel8			
Channel address	I13.0		
DI 16\Digital inputs\Channel9			
Channel address	I13.1		
DI 16\Digital inputs\Channel10			
Channel address	I13.2		
DI 16\Digital inputs\Channel11			
Channel address	I13.3		
DI 16\Digital inputs\Channel12			
Channel address	I13.4		
DI 16\Digital inputs\Channel13			
Channel address	I13.5		
DI 16\Digital inputs\Channel14			
Channel address	I13.6		
DI 16\Digital inputs\Channel15			
Channel address	I13.7		
DI 16\I/O addresses\Input addresses			
Start address	12.0	End address	13.7
Process image	Cyclic PI		

## A1-DIO/DO0 [CPU 1214C DC/DC/DC] / Local modules

### A1-DO1

A1-DO1			
General\Project information			
Name	A1-DO1	Author	Michal Lorenc
Comment		Slot	4
General\Catalog information			
Short designation	SM 1222 DQ8 x 24VDC	Description	Digital output module DQ8 x 24VDC; plug-in terminal blocks
Article number	6ES7 222-1BF32-0XB0	Firmware version	V2.0
DQ 8\Project information			
Name	A1-DO1	Comment	
DQ 8\Digital outputs			
Reaction to CPU STOP	Use substitute value		
DQ 8\Digital outputs\Channel0			
Channel address	Q16.0	Substitute a value of 1 on a change from RUN to STOP.	0
DQ 8\Digital outputs\Channel1			
Channel address	Q16.1	Substitute a value of 1 on a change from RUN to STOP.	0
DQ 8\Digital outputs\Channel2			
Channel address	Q16.2	Substitute a value of 1 on a change from RUN to STOP.	0
DQ 8\Digital outputs\Channel3			
Channel address	Q16.3	Substitute a value of 1 on a change from RUN to STOP.	0
DQ 8\Digital outputs\Channel4			
Channel address	Q16.4	Substitute a value of 1 on a change from RUN to STOP.	0
DQ 8\Digital outputs\Channel5			
Channel address	Q16.5	Substitute a value of 1 on a change from RUN to STOP.	0
DQ 8\Digital outputs\Channel6			
Channel address	Q16.6	Substitute a value of 1 on a change from RUN to STOP.	0
DQ 8\Digital outputs\Channel7			
Channel address	Q16.7	Substitute a value of 1 on a change from RUN to STOP.	0
DQ 8\I/O addresses\Output addresses			
Start address	16.0	End address	16.7
Process image	Cyclic PI		

## A1-DIO/DO0 [CPU 1214C DC/DC/DC] / Local modules

### A1-DO2

A1-DO2			
General\Project information			
Name	A1-DO2	Author	Michal Lorenc
Comment		Slot	5
General\Catalog information			
Short designation	SM 1222 DQ8 x 24VDC	Description	Digital output module DQ8 x 24VDC; plug-in terminal blocks
Article number	6ES7 222-1BF32-0XB0	Firmware version	V2.0
DQ 8\Project information			
Name	A1-DO2	Comment	
DQ 8\Digital outputs			
Reaction to CPU STOP	Use substitute value		
DQ 8\Digital outputs\Channel0			
Channel address	Q20.0	Substitute a value of 1 on a change from RUN to STOP.	0
DQ 8\Digital outputs\Channel1			
Channel address	Q20.1	Substitute a value of 1 on a change from RUN to STOP.	0
DQ 8\Digital outputs\Channel2			
Channel address	Q20.2	Substitute a value of 1 on a change from RUN to STOP.	0
DQ 8\Digital outputs\Channel3			
Channel address	Q20.3	Substitute a value of 1 on a change from RUN to STOP.	0
DQ 8\Digital outputs\Channel4			
Channel address	Q20.4	Substitute a value of 1 on a change from RUN to STOP.	0
DQ 8\Digital outputs\Channel5			
Channel address	Q20.5	Substitute a value of 1 on a change from RUN to STOP.	0
DQ 8\Digital outputs\Channel6			
Channel address	Q20.6	Substitute a value of 1 on a change from RUN to STOP.	0
DQ 8\Digital outputs\Channel7			
Channel address	Q20.7	Substitute a value of 1 on a change from RUN to STOP.	0
DQ 8\I/O addresses\Output addresses			
Start address	20.0	End address	20.7
Process image	Cyclic PI		