



BRNO UNIVERSITY OF TECHNOLOGY



FACULTY OF MECHANICAL  
ENGINEERING  
INSTITUTE OF SOLID MECHANICS,  
MECHATRONICS AND  
BIOMECHANICS

MECHATRONIC DESIGN AND VERIFICATION OF  
AUTONOMIC THERMOELECTRIC ENERGY  
SOURCE  
FOR AIRCRAFT APPLICATION

THESIS

AUTHOR

Ing. ZDENĚK ANČÍK

SUPERVISOR

doc. Ing. RADEK VLACH, Ph.D.

BRNO 2015

## **Abstract**

This thesis deals with the complex mechatronic design of autonomic thermoelectric source of energy for aircraft application. The study of theoretical background and the state-of-the-art based on available sources are summarized at the beginning of this thesis. The numerical models of two commercially available MEMS thermoelectric modules are created and verified with datasheet values. According to the model-based design, the three prototypes are designed, manufactured and experimentally tested under real condition.

## **Key words**

Thermoelectric generator, energy harvesting, simulation modelling, aircraft application, autonomous sensor nodes, health structure monitoring, TEG, MEMS.

## **Motto**

*„There is a fact, or if you wish, a law governing all natural phenomena that are known to date. There is no known exception to this law – it is exact so far as we know. The law is called the conservation of energy.*

*It states that there is a certain quantity, which we call “energy,” that does not change in the manifold changes that nature undergoes. That is a most abstract idea, because it is a mathematical principle; it says there is a numerical quantity, which does not change when something happens.*

*It is not a description of a mechanism, or anything concrete; it is a strange fact that when we calculate some number and when we finish watching nature go through her tricks and calculate the number again, it is the same.*

*It is important to realize that in physics today, we have no knowledge of what energy “is.” We do not have a picture that energy comes in little blobs of a definite amount. It is not that way. It is an abstract thing in that it does not tell us the mechanism or the reason for the various formulas.“*

Richard Phillips Feynman (1964)

1	Introduction .....	5
2	Motivation .....	7
2.1	Research goals .....	7
3	Approaches .....	8
3.1	Mechatronics.....	8
3.2	Model - based design .....	10
4	Fundamentals of thermoelectricity .....	13
4.1	Introduction .....	13
4.2	Seebeck effect .....	13
5	Design of thermoelectric modules.....	15
5.1	Common thermoelectric modules .....	15
5.2	MEMS thermoelectric modules .....	16
5.3	Thin-film thermoelectric layers .....	17
6	Application and requirements .....	18
6.1	Specification.....	18
7	Model of the MEMS TEM MPG-D751.....	19
7.1	Results of the simulation of MPG-D751 module .....	20
8	Power management design .....	24
9	TEG prototype B.....	25
9.1	Design of the prototype B .....	25
9.2	Results of the simulation .....	26
9.3	Testing of prototype B.....	28
9.3.1	Installation .....	28
9.3.2	Measurement description .....	29
9.3.3	Temperature properties.....	30
9.3.4	Electric output characteristic.....	31
9.3.5	Evaluation of the experimental testing .....	32
10	Conclusion .....	33
	References .....	35

## 1 Introduction

This work deals with methods of complex design process and verification of autonomic thermoelectric energy source for aircraft application with using the modern engineering tools and approaches.

A future and development of today's society strongly depends on an ability to utilize clean and renewable energy sources. Energy harvesting (EH) is a new independent branch and current trend in this area, which uses energy freely available in the environment. One of the prospective ways of energy harvesting is based on thermoelectric generator (TEG). The TEG technology is based on the Seebeck effect, which describes direct conversion of temperature difference into the electromotive force (voltage). *“When the junction between dissimilar conductors is heated, electrons are enabled to pass from the material in which the electrons have the lower energy into that in which their energy is higher, giving rise to an electromotive force.”*

[1]

New thermoelectric materials and microelectromechanical systems (MEMS) technologies used in manufacturing process of the thermoelectric modules (TEM) significantly reduces their dimensions and provide sufficient level of the generated power. These are the prospective ways to design the autonomic energy source for wide range of applications. In considering high progress in development of an electronic devices, especially their miniaturization and reduction of energy consumption, the EH technologies becomes ideal solution for their energy supply.

With respect to wide range of aircraft operational temperature conditions, the aircraft applications seem to be

suitable for thermoelectric technology. The natural temperature gradients ensured due to high operating altitude, heat generated by passengers, temperature on board and nearby engine bay are potential sources of electric energy.

The autonomic energy source based on MEMS TEG technology is a technical object, which needs to be designed with respect to its interdisciplinary character and can be classified as a mechatronic system. Mechatronics is defined as *“The design philosophy that utilizes the synergistic integration of mechanical engineering with electronics and electrical systems with intelligent computer control in the design and manufacture of industrial products, processes and operations.”* [2] In accordance with this philosophy, the method of design process is developed using the new engineering tools and approaches. The integration of model based design (MBD) approach, simulation modelling and experimental testing leads to develop the enhance design process and more functional, adaptable and competitive product.

## **2 Motivation**

The main aims in an aircraft development are increasing of safety and reducing an operating cost with respect to environmental protection. The utilization and integration of new sophisticated electronic systems plays an important role in this field. In many cases a sensing of significant parameters are required. For example monitoring of airframe construction, passenger's activity, cargo space or special application in the field of military or rescue service technologies.

In the most cases, these sensors need to be placed in hard to reach places, far away of common power lines. The principle of wireless sensor network based on autonomous sensor nodes technology covers requirements for sensing devices. This technology makes special requirements on research and development of new autonomous energy sources.

### **2.1 Research goals**

This thesis deals with complex mechatronic design and verification of autonomic thermoelectric source of energy for aircraft applications utilizing modern engineering approaches.

The goals of the thesis:

1. Mechatronic design
2. Complex simulation model of the system
3. Experimental testing

### 3 Approaches

The modern engineering method for complex development process of autonomic thermoelectric energy source based on mechatronics principles and model-based design are applied.

#### 3.1 Mechatronics

*„The mechatronics is the complex interdisciplinary approach in the design of technical objects integrated the mechanical engineering, electrical engineering and computer science with using the synergic effect to enhance the functionality, reliability, manufacturability and competitiveness.“ [2]*

The autonomic thermoelectric energy source for aircraft application is high complex technical object classified as a mechatronic system. To reach the optimal design, the integration of knowledge of mechanical engineering, electrical engineering and thermoelectric is required. Interdisciplinary approach is shown in Fig. 1.

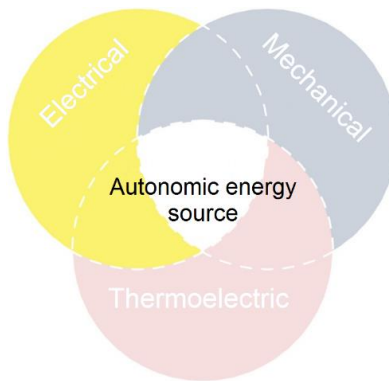

*Fig. 1 Mechatronic approach*

According to the mechatronic approach the autonomic thermoelectric energy source is divided into three main subsystems – mechanical, electrical and thermoelectric, see Fig. 2.

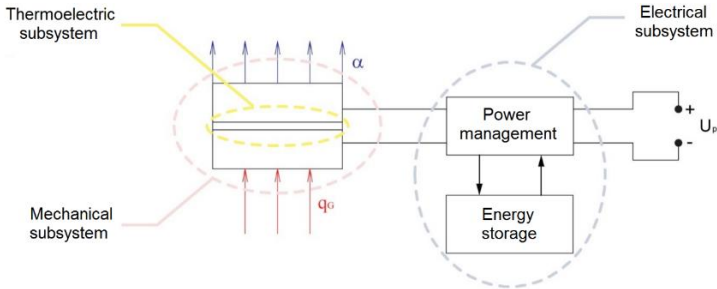

*Fig. 2 Mechatronic subsystems applied on autonomic thermoelectric energy source*

The description of the mechatronic subsystems:

- **Mechanical subsystem** – the purpose is to integrate the TEM to the suitable place and enhance the optimal temperature gradient in wide range of operational conditions.
- **Electrical subsystem** – called power management, the aim is to transform the energy obtained by thermoelectric subpart to the voltage level required by powered device with respect to the maximum power transfer efficiency.
- **Thermoelectric subsystem** – is represent by TEM and ensures the thermoelectric energy conversion.

### 3.2 Model - based design

The model – based design (MBD) [49] is the development process of complex mechatronic systems. MBD is utilizable in wide range of modern engineering design especially in airspace and automotive. Defines a principles and automatism, which leads to save the time and costs in development process and increase the value of developed products.

The MBD is based on the virtual model. Models of each subsystems are created and their interactions are defined. The scheme of MBD process is shown in Fig. 3.

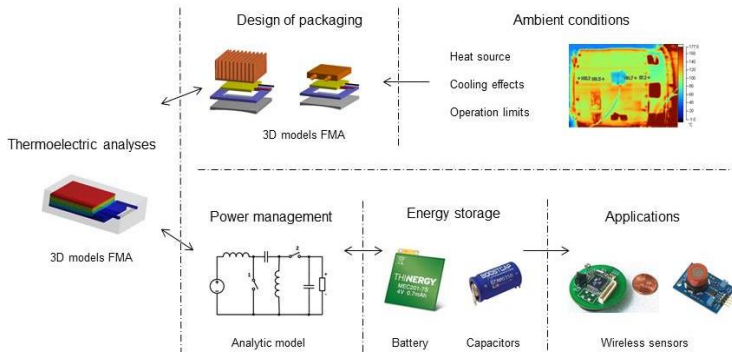

Fig. 3 The development process of thermoelectric autonomous power source

The current trend in MBD is an utilization of models based on the finite element method (FEM) which is a mathematical technique used for finding an appropriate solution for boundary value problems with differential equations. FEM is frequently integrated in commercially available software tools, which offers many features and integrated algorithm for the simulation modelling. However, the knowledge of the fundamental physical and

mathematical phenomena is essential for the proper simulation model design and results interpretation.

The identification of boundary conditions and evaluation of the results of simulation modelling is based on the experimental testing which is essential in development process as well. These processes are integrated into the development macrocycle.

The development of autonomous energy source is described by the macrocycle known as a V–diagram and shown in the following figure Fig. 4. [50]

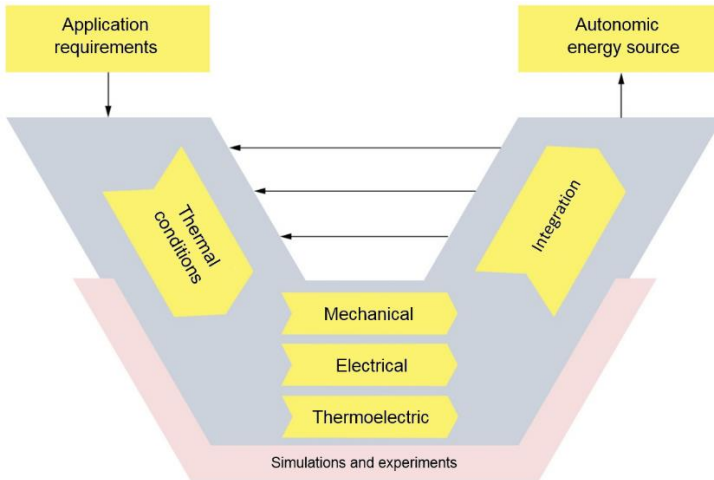

*Fig. 4 Development macrocycle the V - model*

The V-diagram is applied in the development process of simulation model, operational sample or prototype. Repetitive application of the V–diagram increases the performance of the developed products and leads to the optimal design, see Fig. 5.

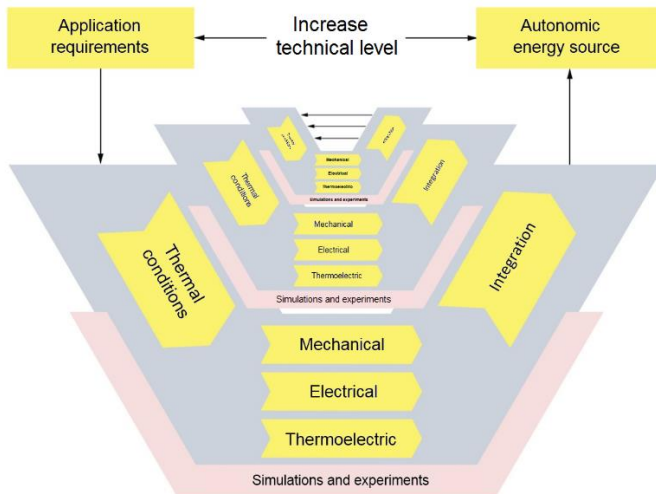

*Fig. 5 Repetitive V-diagram*

## **4 Fundamentals of thermoelectricity**

### **4.1 Introduction**

The thermoelectric theory is based on the Seebeck effect discovered in 1821 by German physicist T. J. Seebeck. „*He showed that an electromotive force could be produced by heating the junction between two different electrical conductors.*” [1]

In 1834, the French watchmaker J. Peltier observed another thermoelectric effect. „*He found that the passage of an electric current through a thermocouple produces a small heating or cooling effect depending on its direction.*” [1]

The Peltier and Seebeck effects are related as was founded and described by W. Thomson in 1855. He applied the thermodynamic theory to the problem and found out the third thermoelectric effect – Thomson effect, which describes heating or cooling of a current-carrying conductor with a temperature gradient.

### **4.2 Seebeck effect**

The Seebeck effect is a phenomenon based on the diffusion of electrons through the interface between two different materials – conductors or semiconductors. This diffusion is caused by heating applied at a junction of two materials, which create a thermocouple together Fig. 6. Heating causes the net changes in the materials and allows electrons to move from a material where the energy is lower in a material where the energy of electrons is higher. However, the electrical current is exactly a flow of electrons this effect of passing electrons from one material to another makes an electromotive force (voltage). [1]

The value of the generated voltage is given by:

$$U = \alpha_{AB} \cdot (T_H - T_C) \quad (\text{Eq. 1})$$

where:

- $\alpha_{AB}$  differential Seebeck coefficient [V/K]
- $U$  voltage [V]
- $T_H$  temperature of the hot side [K]
- $T_C$  temperature of the cold side [K].

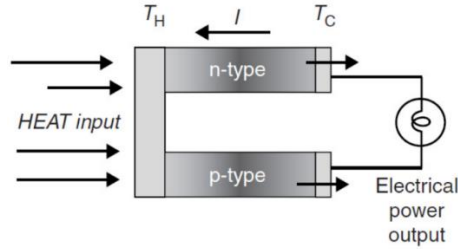

Fig. 6 Thermocouple – Seebeck effect [25]

The voltage generated by thermocouple is independent on bulk properties of the material but it is linearly dependent on the differential Seebeck coefficient  $\alpha_{AB}$ , which is a material property of both materials:

$$\alpha_{AB} = \alpha_A - \alpha_B \quad (\text{Eq. 2})$$

where:

- $\alpha_{AB}$  differential Seebeck coefficient [V/K],
- $\alpha_A$  Seebeck coefficient of the material A [V/K],
- $\alpha_B$  Seebeck coefficient of the material B [V/K].

## 5 Design of thermoelectric modules

### 5.1 Common thermoelectric modules

The thermoelectric module (TEM) is consisted of thermoelectric layer, which is sandwiched between two electrically isolated wafers. [1] The thermoelectric layer is made of number of the thermocouples connected electrically in series and thermally in parallel as is shown in the following Fig. 7.

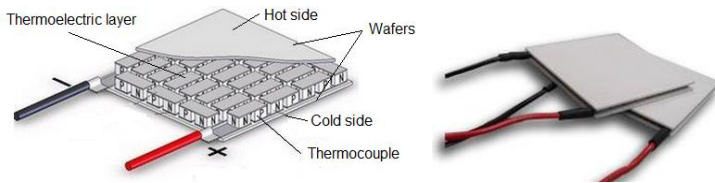
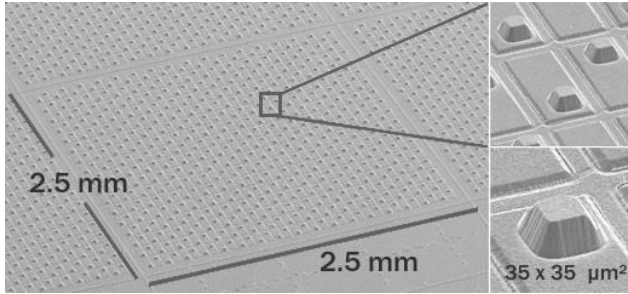

*Fig. 7 Design of thermoelectric module*

The TEM can be designed in different size, shape and generated power require by application. Common modules are designed in size of centimetres and are able to generate tens of watts.

## 5.2 MEMS thermoelectric modules

Thanks to the MEMS technologies the TEMs significantly reduce their dimensions. The special manufacturing process enable to create the thermoelectric array with high density of thermocouples see Fig. 8.



*Fig. 8 MEMS thermoelectric array*

The TEMs based on this technology are able to generate power in tens of mill watts and seems to be ideal solution for aircraft energy harvesting applications. The size of common and MEMS TEM are compared in Fig. 9.

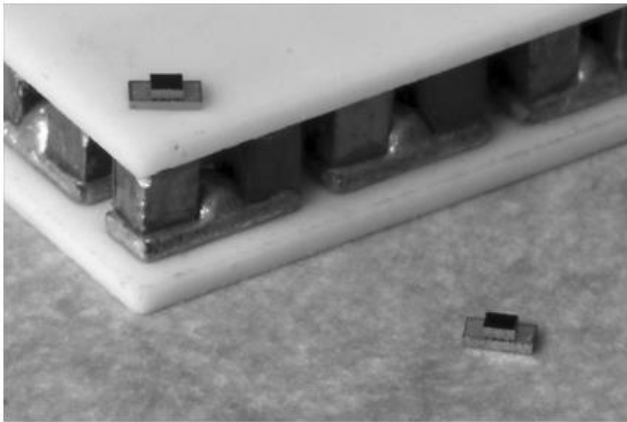

*Fig. 9 Size comparison of common and MEMS TEM*

### 5.3 Thin-film thermoelectric layers

Nowadays the thin-film thermoelectric layers are subject of research all over the world. [51] The printed electronics technologies enable to create very thin and flexible thermoelectric layers see Fig. 10. These technologies are not commercially available but the research in this field significantly develop the thermoelectric technologies.

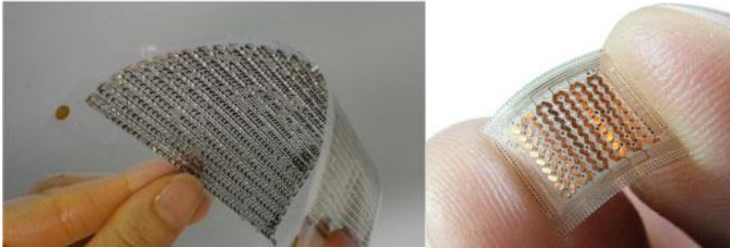
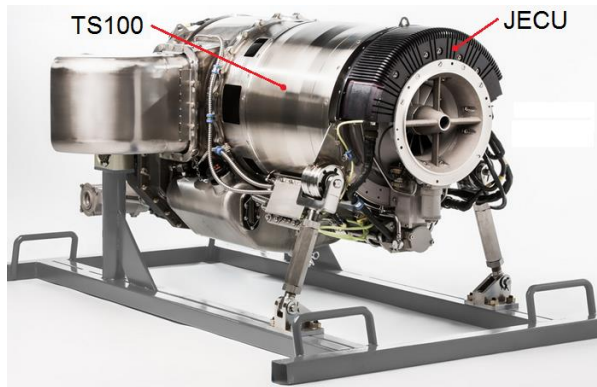

*Fig. 10 Thin-film thermoelectric layers [27]*

## 6 Application and requirements

### 6.1 Specification

The aim of an autonomic thermoelectric generator is to provide electric power supply for the autonomous over-speed protection circuit implemented in Jet Control Unit (JECU) for turbo-shaft aircraft engine TS100, see Fig. 11 in the case of failure in on-board power supply.



*Fig. 11 Turbo-shaft engine TS100*

The minimum supply power requirements of over-speed transmitter application:

- supplied system voltage: 5 V
- power consumption: 100 mW (current 20mA)
- continuous operating time: 30 min.
- operating temperature range:  $-50^{\circ}\text{C}$  to  $85^{\circ}\text{C}$ .

## 7 Model of the MEMS TEM MPG-D751

The design of the model of MPG-D751 module is shown in the Fig. 12.

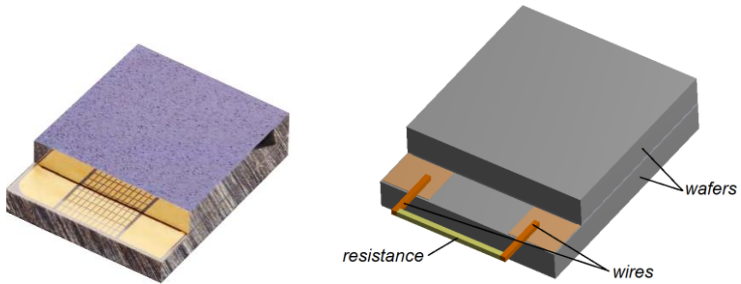

*Fig. 12 Comparison of the geometry of module MPG-D751 and its model*

## 7.1 Results of the simulation of MPG-D751 module

The model is calculated for the boundary conditions in accordance with the presented datasheet characteristic for results comparison and evaluation.

### Temperature distribution

The temperature distribution in the structure of the module Micropelt MPG-D751 is shown in Fig. 13.

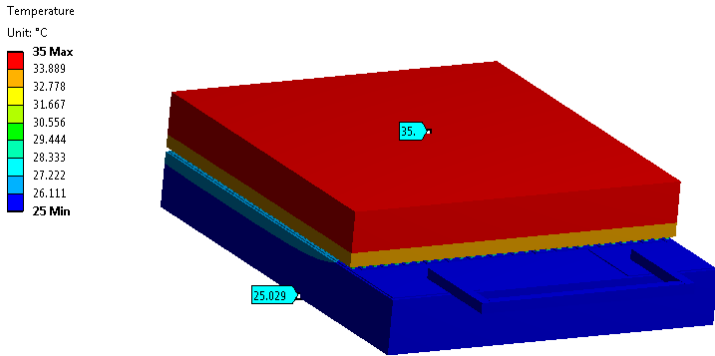

*Fig. 13 Temperature distribution in module MPG-D751*

The detail of the temperature distribution in the thermocouple is shown in Fig. 14.

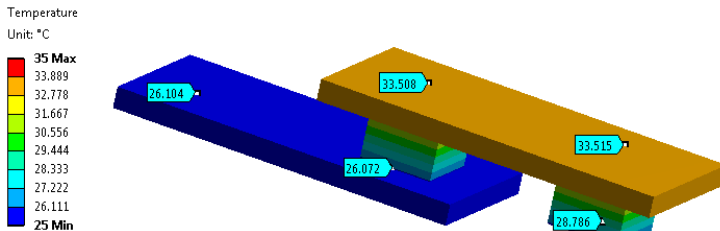

*Fig. 14 Temperature distribution in the thermocouple*

## Voltage distribution

The open-circuit voltage distribution in the Micropelt MPG-D751 module for temperature difference 5 °C is shown in Fig. 15.

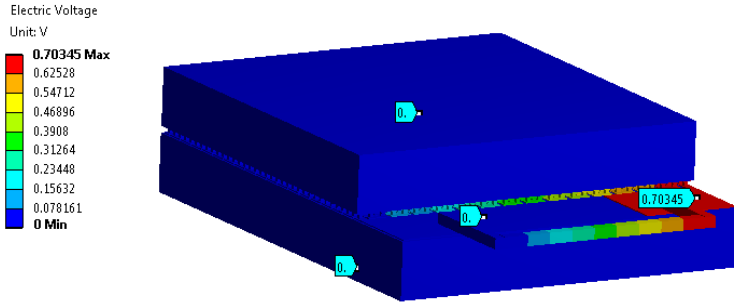

Fig. 15 Voltage distribution in the MPG-D751

The voltage distribution in the thermoelectric layer, see Fig. 16.

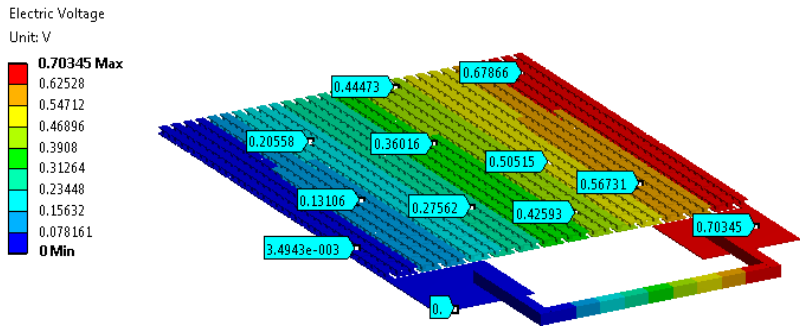

Fig. 16 Voltage distribution in the thermoelectric layer

## Generated power

The current, voltage and generated power are calculated in dependence with load resistance in accordance to datasheet values for results comparison and evaluation.

The voltage vs. load resistance is shown in Fig. 17. The generated voltage is in match with datasheet values.

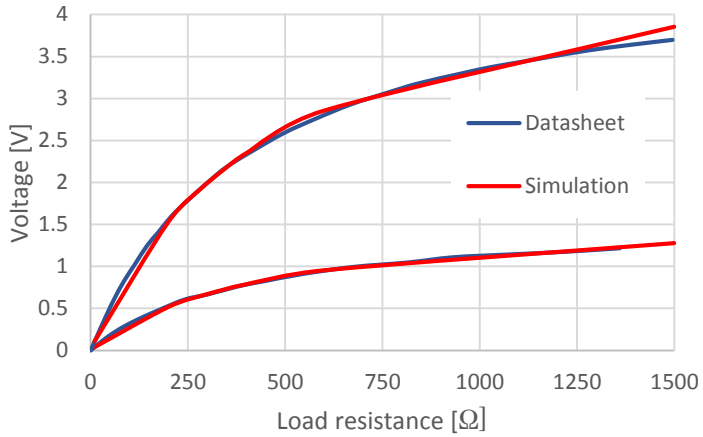

Fig. 17 Voltage vs. load resistance for  $\Delta T=10\text{ }^\circ\text{C}$  and  $\Delta T=30\text{ }^\circ\text{C}$

The generated power in dependence with load resistance is presented in Fig. 18.

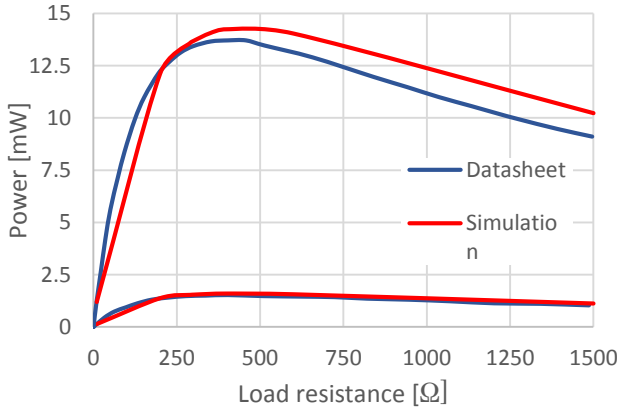

Fig. 18 Power vs. load resistance for  $\Delta T=10\text{ }^{\circ}\text{C}$  and  $\Delta T=30\text{ }^{\circ}\text{C}$

Voltage vs. current curves compared with the datasheet values are shown in Fig. 19.

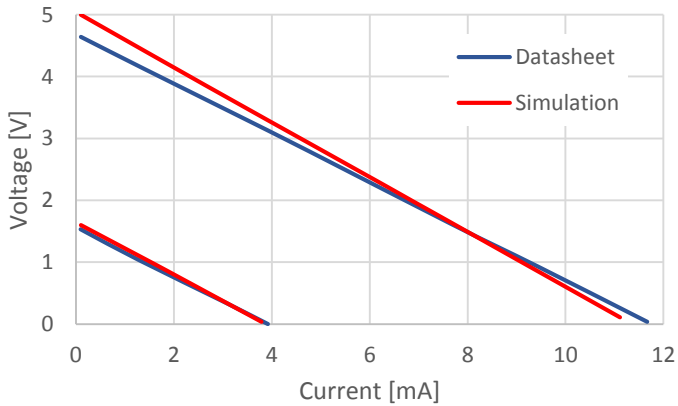
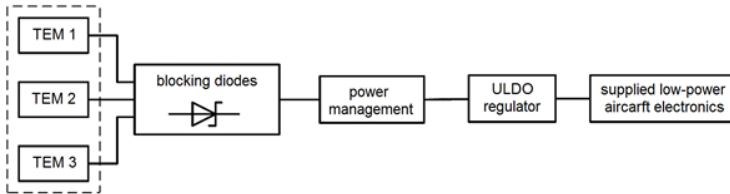

Fig. 19 Voltage vs. current curves for  $\Delta T=10\text{ }^{\circ}\text{C}$  and  $\Delta T=30\text{ }^{\circ}\text{C}$

## 8 Power management design

The power management converts the raw generated energy at the output terminals of the harvester to the useful electric power. The 15 V, 75 mA high efficient buck converter TPS62120 from Texas Instruments is utilized in the design. The TPS62120 is a high efficient synchronous step down DC-DC converter optimized for low power applications. The wide operating input voltage range of 2 V to 15 V supports energy harvesting, battery powered and as well 9 V or 12 V line powered applications.

The block scheme of power management is shown in the following figure Fig. 20.



*Fig. 20 System block diagram of TEG power source for aircraft application*

The power management was realized and successfully tested, see Fig. 21.

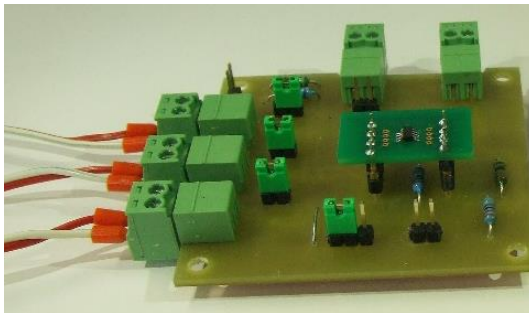

*Fig. 21 Power management with buck converter TPS62120*

## 9 TEG prototype B

The aim of the prototype B is to fulfil the application power requirements defined in chapter 6. The design of prototype B follows the successfully tested conception of prototype A. The next generation was prototype C, but the improvement has not been proven.

### 9.1 Design of the prototype B

The three TEMs Micropelt TGP-751 are used in prototype B as shown in Fig. 22. The aim of the mounting pad and heat sink design is to ensure the similar thermal conditions for all three TEMs.

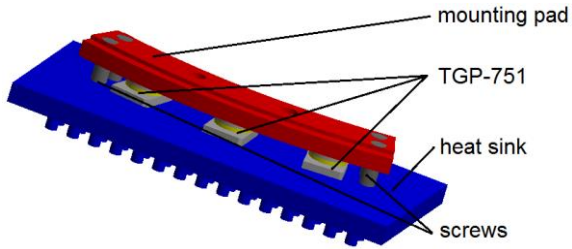
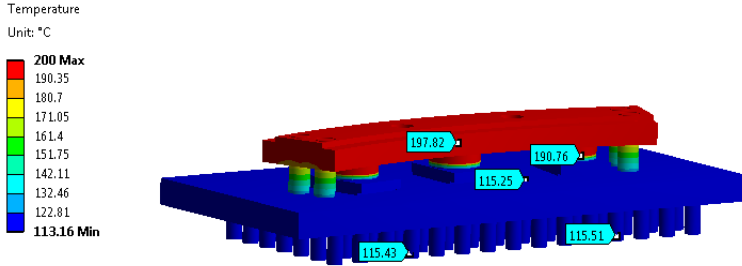

*Fig. 22 Design of prototype B*

The mounting pad and the heat sink are made of aluminium and mounted together by four metal screws.

## 9.2 Results of the simulation

The steady-state temperature distribution of the prototype B is shown in Fig. 23. The temperature of mounting pad is 198 °C and temperature of heat sink is 115 °C.



*Fig. 23 Steady-state temperature of prototype B*

The temperature distribution on the modules TGP-751 integrated into prototype B is shown in Fig. 24. The temperature distribution on each of TGP-751 modules is very similar which is important for their proper behaviour after their parallel electrical connection. The temperature gradient between the hot and cold side of TEMs TGP-751 is 80 °C.

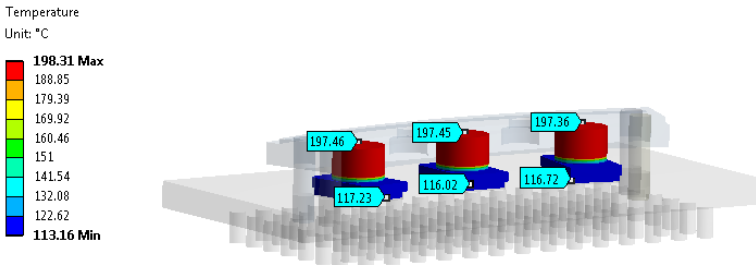

*Fig. 24 Steady-state temperature on TGP-751 of prototype B*

The results of electric output properties of one module are summarized in Tab. 1. The electric power generated by each of the modules is 77.19 mW.

*Tab. 1 Electric properties of single one TEM of prototype B for load resistance 300  $\Omega$*

<b>Electric properties</b>		
Voltage [V]	Current [mA]	Power [mW]
4.82	16.00	77.19

According to the results of simulation, modelling the conception of prototype B is prospective for the realization and experimental testing. The temperature difference on the TEMs TPG-D751 is 80 °C and generated power of each TEM is 77.19 mW.

## 9.3 Testing of prototype B

### 9.3.1 Installation

The prototype B is realized in accordance with the design described above. The three TEMs TPG-D751 are placed between the mounting pad and heat sink. Both parts are tightened together by four screws. The mounting pad was attached into the diffuser of engine TS100 power unit by two screws. The prototype B and its installation are shown in the following Fig. 25.

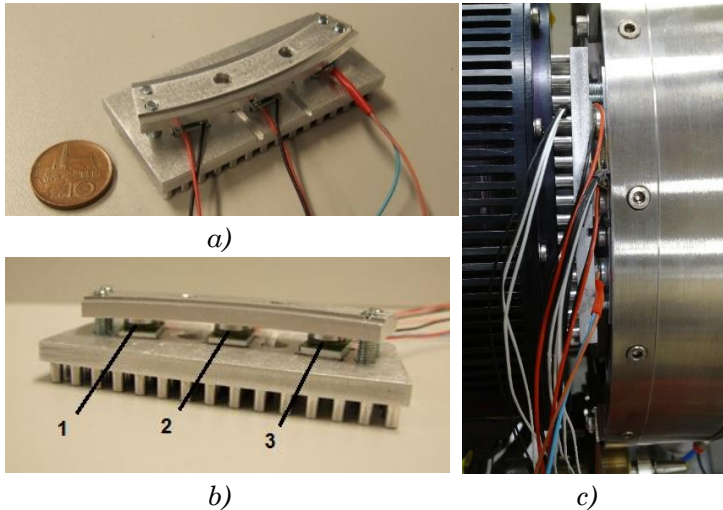

*Fig. 25 Prototype B a) up view b) side view c) installation*

### 9.3.2 Measurement description

The power unit TS100 was run up from the cold-start to the nominal power level. The temperature of hot side, cold side, heat sink and ambient were measured by Pt 100 temperature sensors. The open-circuit voltage and short-circuit current for each TEM and their parallel connection were measured. The scheme of measurement is shown in Fig. 26.

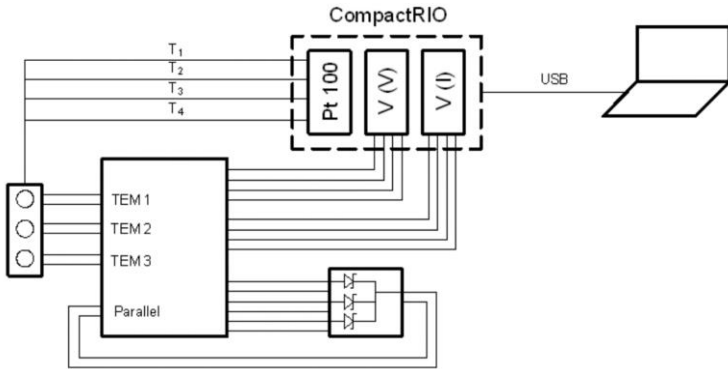

*Fig. 26 Scheme of measurement of prototype B*

### 9.3.3 Temperature properties

The temperatures of hot side, cold side, heat sink and ambient are shown in the following Fig. 27. The power unit TS100 was started up to the nominal power level. The steady state is reached after 900 seconds.

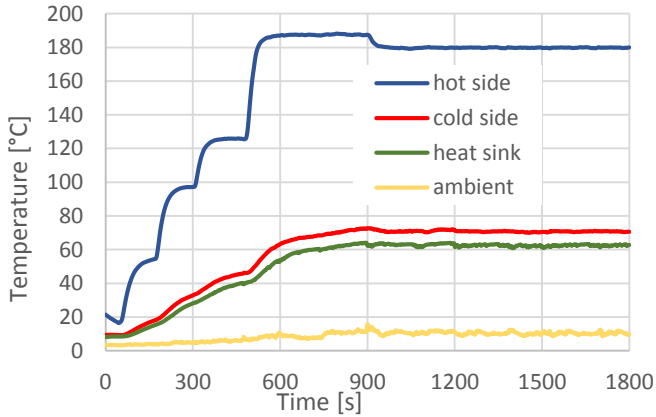

Fig. 27 Temperatures during the stars up of TS100

The values of temperatures in time 1200 seconds are shown in Tab. 2.

Tab. 2 Temperature values of prototype B in time 1200 seconds after start

Temperature			
Hot side [°C]	Cold side	Heat sink	Ambient [°C]
179.8	71.6	66.4	10.8

The temperature gradient achieved between the hot and cold side is around 110 °C.

### 9.3.4 Electric output characteristic

The electric output characteristic are measured in temperatures steady state on nominal power level. Open-circuit voltages of each module are shown in the following figure Fig. 28. The short-circuit current for each module is shown in the Fig. 29.

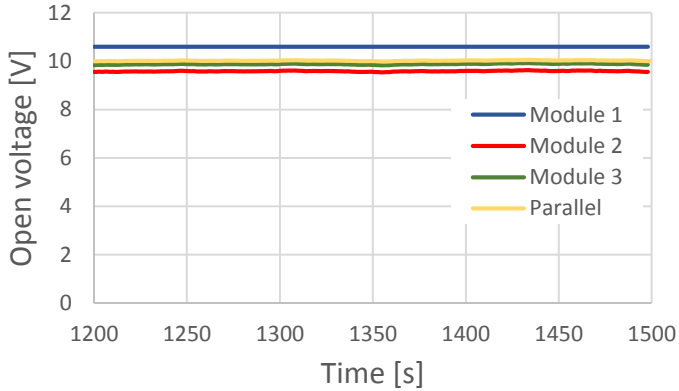

Fig. 28 Open-circuit voltage

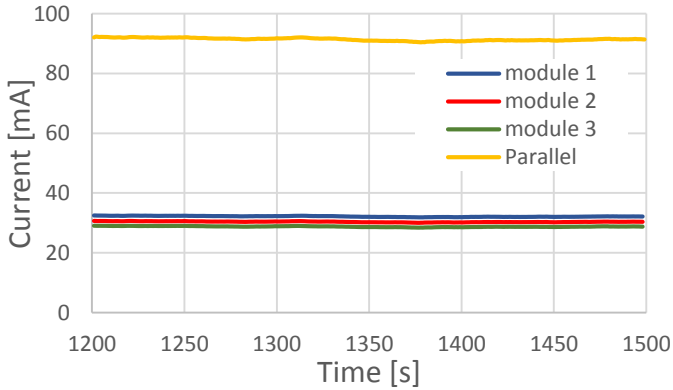

Fig. 29 Short-circuit current

The volt-ampere characteristic for each module are presented in Fig. 30.

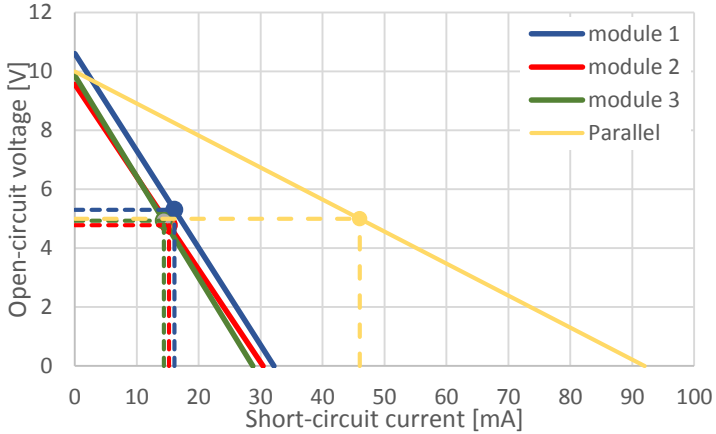

Fig. 30 Volt-ampere characteristics

In accordance with the volt-ampere characteristic the generated power for matched load  $300 \Omega$  of modules are  $P_1=85.2 \text{ mW}$ ,  $P_2=72.7 \text{ mW}$  and  $P_3=70.9 \text{ mW}$ .

### 9.3.5 Evaluation of the experimental testing

In accordance with the presented results of experimental testing, the prototype B is able to generate power of  $P_1=85.21 \text{ mW}$ ,  $P_2=72.78 \text{ mW}$  and  $P_3=70.92 \text{ mW}$  for nominal power operation mode of power unit TS100

## 10 Conclusion

The dissertation thesis deals with a complex mechatronic design and the verification of autonomic thermoelectric sources of electric energy for aircraft applications. The research was based on a study of state-of-the-art in this field. The previously presented solutions in available sources utilized the common thermoelectric modules, while there were applied the MEMS thermoelectric modules in this research. Two commercially available MEMS thermoelectric modules Nextreme HV56 and Micropelt TPG-751 were selected for the design. The precise simulation models of both modules were created and verified with datasheets. The selected modules were experimentally tested in a wide range of operation conditions. The module Micropelt TPG-751 was selected for further development on the base of results of previous experimental testing and simulation modelling

The over-speed transducer for turbo-shaft aircraft engine TS100 was chosen as a prospective application, which supposed to prove the functionality of this technology under the real conditions. The thermal condition of TS100 were studied to find the prospective location for MEMS thermoelectric generator. The prototype A was created and successfully tested on the engine TS100 on the base of the simulation modelling. The prototype A proved the functionality of the thermoelectric generator under real condition. The prototype A was able to generate power 34.2 mW. The design of prototype B was based on the experiences obtained during designing and testing of prototype A. There were used three thermoelectric modules in prototype B to ensure the sufficient power for the prospective application.

The prototype B generated power 228.8 mW. The prototype C was designed with an aim to improve the thermal condition by utilizing the plastic screws between the mounting pad and the heat sink. The contact forces were decreased because of the low rigidity of plastic screws in high temperature conditions. That led to the reduction in the heat flow through the thermoelectric modules. Therefore, the metal screws were utilized as was previously successfully tested in the prototype B. The prototype B was also presented as prototype sample of project CAAEEC. The presented dissertation thesis meets the goals defined in the assignment.

## References

- [1] H. J. Goldsmid, *Introduction to Thermoelectricity*, vol. 121. Berlin, Heidelberg: Springer Berlin Heidelberg, 2010.
- [2] R. H. Bishop, *THE MECHATRONICS*, CRC Press LLC ISBN: 0-8493-0066-5, 2002.
- [3] A. Elefsiniotis, N. Kokorakis, T. Becker, and U. Schmid, "Performance of a low temperature energy harvesting device for powering wireless sensor nodes in aircrafts applications," in *2013 Transducers & Eurosensors XXVII: The 17th International Conference on Solid-State Sensors, Actuators and Microsystems (TRANSDUCERS & EUROSENSORS XXVII)*, 2013, pp. 2276–2279.
- [4] C. Mo and J. Davidson, "Energy harvesting technologies for structural health monitoring applications," in *2013 1st IEEE Conference on Technologies for Sustainability (SusTech)*, 2013, pp. 192–198.
- [5] N. Meyendorf, B. Frankenstein, and L. Schubert, "Structural Health Monitoring for Aircraft , Ground Transportation Vehicles , Wind Turbines and Pipes – Prognosis," no. April, pp. 16–20, 2012.
- [6] S. Black, "New initiatives are mainstreaming real-time monitoring systems into composites on aircraft, wind blades and other critical performance structures," no. September, pp. 54-59, 2008
- [7] J. Demo, A. Steiner, F. Friedersdorf, and M. Putic, "Development of a wireless miniaturized smart sensor network for aircraft corrosion monitoring," in *2010 IEEE Aerospace Conference*, 2010, pp. 1–9.
- [8] S. W. Arms, J. H. Galbreath, C. P. Townsend, D. L. Churchill, B. Corneau, R. P. Ketcham, and N. Phan, "Energy harvesting wireless sensors and networked timing synchronization for aircraft structural health monitoring," in *2009 1st International Conference on Wireless Communication, Vehicular Technology, Information Theory and Aerospace & Electronic Systems Technology*, 2009, pp. 16–20.
- [9] M. Bafleur and J.-M. Dilhac, "Towards Energy Autonomy of Wireless Sensors in Aeronautics Applications: SMARTER Collaborative Project," in *2013 IEEE International Conference on Green Computing and Communications and IEEE Internet of Things and IEEE Cyber, Physical and Social Computing*, 2013, pp. 1668–1672.

- [10] C. W. Group and E. A. Systems, *Energy Autonomous Systems : Future Trends in Devices , Technology , and Systems CATRENE Working Group on Energy Autonomous Systems Energy Autonomous Systems : Future Trends in Devices , Technology , and Systems*. 2009, pp. 1–84.
- [11] M. Belleville, H. Fanet, P. Fiorini, P. Nicole, M. J. M. Pelgrom, C. Piguët, R. Hahn, C. Van Hoof, R. Vullers, M. Tartagni, and E. Cantatore, “Energy autonomous sensor systems: State and perspectives of a ubiquitous sensor technology,” in *2009 3rd International Workshop on Advances in sensors and Interfaces*, 2009, pp. 134–138.
- [12] T. Becker, M. Kluge, J. Schalk, K. Tiplady, C. Paget, and U. Hilleringmann, “Autonomous Sensor Nodes for Structural Health Monitoring,” vol. 9, no. 11, pp. 1589–1595, 2009.
- [13] A. A. Chien and V. Karamcheti, “Moore’s Law: The First Ending and a New Beginning,” *Computer (Long Beach, Calif.)*, vol. 46, no. 12, pp. 48–53, Dec. 2013.
- [14] “More’s low: [https://en.wikipedia.org/wiki/Moore%27s\\_law](https://en.wikipedia.org/wiki/Moore%27s_law).”
- [15] M. Alioto and S. Member, “Ultra-Low Power VLSI Circuit Design Demystified and Explained : A Tutorial,” vol. 59, no. 1, pp. 3–29, 2012.
- [16] “Advanced technology for ultra-low power electronic devices,” *IEEE J. Electron Devices Soc.*, vol. 3, no. 5, pp. 440–440, Sep. 2015.
- [17] C. Ulaganathan, B. J. Blalock, J. Holleman, and C. L. Britton, “An ultra-low voltage self-startup charge pump for energy harvesting applications,” in *2012 IEEE 55th International Midwest Symposium on Circuits and Systems (MWSCAS)*, 2012, pp. 206–209.
- [18] L. Huang, V. Pop, R. de Francisco, R. Vullers, G. Dolmans, H. de Groot, and K. Imamura, “Ultra low power wireless and energy harvesting technologies — An ideal combination,” in *2010 IEEE International Conference on Communication Systems*, 2010, pp. 295–300.
- [19] F. Breu, S. Guggenbichler, and J. Wollmann, *Energy Harvesting Technologies*. Boston, MA: Springer US, 2009.
- [20] L. Mateu and F. Moll, “Review of energy harvesting techniques and applications for microelectronics,” *Proc. SPIE 5837 VLSI Circuits Syst. II*, pp. 359–373, 2005.
- [21] M. C. Hamilton, “Recent advances in energy harvesting technology and techniques,” in *IECON 2012 - 38th Annual Conference on IEEE Industrial Electronics Society*, 2012, pp. 6297–6304.

- [22] Z. Hadas, V. Vetiska, V. Singule, O. Andrs, J. Kovar, and J. Vetiska, "Energy Harvesting from Mechanical Shocks Using A Sensitive Vibration Energy Harvester," *Int. J. Adv. Robot. Syst.*, p. 1, 2012.
- [23] M. E. Kiziroglou, S. W. Wright, T. T. Toh, P. D. Mitcheson, T. Becker, and E. M. Yeatman, "Design and Fabrication of Heat Storage Thermoelectric Harvesting Devices," *IEEE Trans. Ind. Electron.*, vol. 61, no. 1, pp. 302–309, Jan. 2014.
- [24] D. Park, "Energy Harvesting and Storage for Electronic Devices," 2010.
- [25] D. M. Rowe, *Thermoelectrics Handbook*, vol. 23, no. 1. CRC Press, 2005, pp. 55–55.
- [26] "The condition trend analysis of aircraft key components based on D-S evidence theory," in *2012 24th Chinese Control and Decision Conference (CCDC)*, 2012, pp. 2264–2269.
- [27] D. Madan, A. Chen, P. K. Wright, and J. W. Evans, "Dispenser printed composite thermoelectric thick films for thermoelectric generator applications," *J. Appl. Phys.*, vol. 109, no. 3, p. 034904, 2011.
- [28] L. Francioso, C. De Pascali, P. Siciliano, A. De Risi, R. Bartali, E. Morganti, and L. Lorenzelli, "Structural reliability and thermal insulation performance of flexible thermoelectric generator for wearable sensors," in *2013 IEEE SENSORS*, 2013, pp. 1–4.
- [29] S. Reddy and C. R. Murthy, "Dual-Stage Power Management Algorithms for Energy Harvesting Sensors," *IEEE Trans. Wirel. Commun.*, vol. 11, no. 4, pp. 1434–1445, Apr. 2012.
- [30] "A Joint Duty-Cycle and Transmission Power Management for Energy Harvesting WSN," *IEEE Trans. Ind. Informatics*, vol. 10, no. 2, pp. 928–936, May 2014.
- [31] "A Micro Inertial Energy Harvesting Platform With Self-Supplied Power Management Circuit for Autonomous Wireless Sensor Nodes," *IEEE J. Solid-State Circuits*, pp. 1–13, 2014.
- [32] "Harvesting-Aware Power Management for Real-Time Systems With Renewable Energy," *IEEE Trans. Very Large Scale Integr. Syst.*, vol. 20, no. 8, pp. 1473–1486, Aug. 2012.
- [33] A. Montecucco, J. Siviter, and A. R. Knox, "Simple , Fast and Accurate Maximum Power Point Tracking Converter for Thermoelectric Generators," pp. 2777–2783, 2012.
- [34] S. Kim, S. Cho, N. Kim, and J. Park, "A maximum power point tracking circuit of thermoelectric generators without digital controllers," *IEICE Electron. Express*, vol. 7, no. 20, pp. 1539–1545, 2010.

- [35] M. Aureliano, G. De Brito, L. Galotto, L. P. Sampaio, G. De Azevedo, C. A. Canesin, and S. Member, "Evaluation of the Main MPPT Techniques for Photovoltaic Applications," vol. 60, no. 3, pp. 1156–1167, 2013.
- [36] J. Park and S. Kim, "Maximum Power Point Tracking Controller for Thermoelectric Generators with Peak Gain Control of Boost DC–DC Converters," *J. Electron. Mater.*, vol. 41, no. 6, pp. 1242–1246, Jan. 2012.
- [37] J. Ahmad, "A fractional open circuit voltage based maximum power point tracker for photovoltaic arrays," in *2010 2nd International Conference on Software Technology and Engineering*, 2010.
- [38] K. L. Lian, J. H. Jhang, and I. S. Tian, "A Maximum Power Point Tracking Method Based on Perturb-and-Observe Combined With Particle Swarm Optimization," *IEEE J. Photovoltaics*, vol. 4, no. 2, pp. 626–633, Mar. 2014.
- [39] C. Zhao, H. Yin, Y. Noguchi, and C. Ma, "Quantitative analysis on energy efficiency of a battery-ultracapacitor hybrid system," in *2014 IEEE 23rd International Symposium on Industrial Electronics (ISIE)*, 2014, pp. 1829–1835.
- [40] J. F. Ribeiro, R. Sousa, J. A. Sousa, L. M. Goncalves, M. M. Silva, L. Dupont, and J. H. Correia, "Flexible thin-film rechargeable lithium battery," in *2013 Transducers & Eurosensors XXVII: The 17th International Conference on Solid-State Sensors, Actuators and Microsystems (TRANSDUCERS & EUROSENSORS XXVII)*, 2013, pp. 2233–2236.
- [41] A. Saez-de-Ibarra, A. Milo, H. Gaztanaga, I. Etxeberria-Otadui, P. Rodriguez, S. Bacha, and V. Debusschere, "Analysis and comparison of battery energy storage technologies for grid applications," in *2013 IEEE Grenoble Conference*, 2013, pp. 1–6.
- [42] D. Samson, T. Otterpohl, M. Kluge, U. Schmid, and T. Becker, "Aircraft-Specific Thermoelectric Generator Module," *J. Electron. Mater.*, vol. 39, no. 9, pp. 2092–2095, Nov. 2009.
- [43] T. Becker, M. Kluge, J. Schalk, T. Otterpohl, and U. Hilleringmann, "Power management for thermal energy harvesting in aircrafts," in *2008 IEEE Sensors*, 2008, pp. 681–684.
- [44] a. Elefsiniotis, D. Samson, T. Becker, and U. Schmid, "Investigation of the Performance of Thermoelectric Energy Harvesters Under Real Flight Conditions," *J. Electron. Mater.*, vol. 42, no. 7, pp. 2301–2305, Jan. 2013.
- [45] D. Samson, M. Kluge, T. Fuss, U. Schmid, and T. Becker, "Flight Test Results of a Thermoelectric Energy Harvester for Aircraft," *J. Electron. Mater.*, vol. 41, no. 6, pp. 1134–1137, Feb. 2012.

- [46] K. Thangaraj, a. Elefsiniotis, T. Becker, U. Schmid, J. Lees, C. a. Featherston, and R. Pullin, "Energy storage options for wireless sensors powered by aircraft specific thermoelectric energy harvester," *Microsyst. Technol.*, vol. 20, no. 4–5, pp. 701–707, Dec. 2013.
- [47] M. E. Kiziroglou, S. W. Wright, T. T. Toh, T. Becker, P. D. Mitcheson, E. M. Yeatman, D. U. W. Gxw, F. F. Dylrqlf, and Z. Vhqvruv, "HEAT STORAGE POWER SUPPLY FOR WIRELESS AIRCRAFT SENSORS," vol. 1, pp. 7–10, 2012.
- [48] A. Elefsiniotis, T. Becker, and U. Schmid, "Thermoelectric Energy Harvesting Using Phase Change Materials (PCMs) in High Temperature Environments in Aircraft," *J. Electron. Mater.*, vol. 43, no. 6, pp. 1809–1814, Nov. 2013.
- [49] J. Liu and Z. Zhao, "A method of categorization and organization for 3D model-based design knowledge," in *The 2014 2nd International Conference on Systems and Informatics (ICSAI 2014)*, 2014, pp. 344–349.
- [50] Z. Hadas, V. Vetiska, R. Huzlik, and V. Singule, "Model-based design and test of vibration energy harvester for aircraft application," *Microsyst. Technol.*, vol. 20, no. 4–5, pp. 831–843, Jan. 2014.
- [51] K. Kato, T. Muto, T. Kondo, and K. Miyazaki, "Fabrication of flexible thermoelectric thin film module using micro porous structure," in *IEEE CPMT Symposium Japan 2014*, 2014, pp. 182–185.
- [52] R. McCarty, "Thermoelectric Power Generator Design for Maximum Power: It's All About ZT," *J. Electron. Mater.*, vol. 42, no. 7, pp. 1504–1508, Oct. 2012.
- [53] L. Janák, "APPLICATION OF MEMS TECHNOLOGY IN THE FIELD OF THERMOELECTRIC GENERATORS," Brno University of technology, 2012.
- [54] M. Chen, Y. Sasaki, and R. O. Suzuki, "Computational Simulation of Thermoelectric Generators in Marine Power Plants," *Mater. Trans.*, vol. 52, no. 8, pp. 1549–1552, 2011.
- [55] P. Dziurdzia, "Simulation tool for virtual estimation of harvested thermoelectric energy supplying wireless sensor nodes," *2010 2nd Int. Conf. Softw. Technol. Eng.*, pp. 414–418, Oct. 2010.
- [56] P. Dziurdzia and A. Mirocha, "From Constant to Temperature Dependent Parameters Based Electrothermal Models of TEG Comparative Analysis," pp. 0–4, 2009.
- [57] S. Lineykin and S. Ben-Yaakov, "Modeling and analysis of thermoelectric modules," *Twent. Annu. IEEE Appl. Power Electron. Conf. Expo. 2005. APEC 2005.*, vol. 3, pp. 2019–2023, 2005.

- [58] S. Lineykin and S. Ben-Yaakov, "Modeling and Analysis of Thermoelectric Modules," *IEEE Trans. Ind. Appl.*, vol. 43, no. 2, pp. 505–512, 2007.
- [59] A. Mirocha and P. Dziurdzia, "Improved Electrothermal Model of the Thermoelectric Generator Implemented in SPICE," pp. 317–320, 2008.
- [60] F. Felgner and G. Frey, "Object-oriented simulation model of thermoelectric devices for energy system design," *2012 16th IEEE Mediterr. Electrotech. Conf.*, pp. 577–580, Mar. 2012.
- [61] H.-L. Tsai and J.-M. Lin, "Model Building and Simulation of Thermoelectric Module Using Matlab/Simulink," *J. Electron. Mater.*, vol. 39, no. 9, pp. 2105–2111, Nov. 2009.
- [62] M. Chen, S. J. Andreasen, L. Rosendahl, S. K. Kær, and T. Condra, "System Modeling and Validation of a Thermoelectric Fluidic Power Source: Proton Exchange Membrane Fuel Cell and Thermoelectric Generator (PEMFC-TEG)," *J. Electron. Mater.*, vol. 39, no. 9, pp. 1593–1600, Jun. 2010.
- [63] M. Chen, L. a. Rosendahl, and T. Condra, "A three-dimensional numerical model of thermoelectric generators in fluid power systems," *Int. J. Heat Mass Transf.*, vol. 54, no. 1–3, pp. 345–355, Jan. 2011.
- [64] a. Rezania and L. a. Rosendahl, "Thermal Effect of Ceramic Substrate on Heat Distribution in Thermoelectric Generators," *J. Electron. Mater.*, vol. 41, no. 6, pp. 1343–1347, Feb. 2012.
- [65] Y. Shiyang, F. Jiaojiao, and C. Dong, "Dynamic modeling for thermoelectric equipments," *2012 IEEE Int. Symp. Ind. Electron.*, pp. 999–1002, May 2012.
- [66] M. Chen, S. Member, L. A. Rosendahl, T. J. Condra, J. K. Pedersen, and S. Member, "Numerical Modeling of Thermoelectric Generators With Varying Material Properties in a Circuit Simulator," vol. 24, no. 1, pp. 112–124, 2009.
- [67] S. Ruiyin, L. Wei, Y. Canjun, and L. Yisheng, "Modeling and Simulate Analysis for Micro-Thermoelectric Generator," *Proceedings, 2005 IEEE/ASME Int. Conf. Adv. Intell. Mechatronics.*, pp. 255–260, 2005.
- [68] R. McCarty, "A Comparison Between Numerical and Simplified Thermoelectric Cooler Models," *J. Electron. Mater.*, vol. 39, no. 9, pp. 1842–1847, Feb. 2010.
- [69] E. E. Antonova, D. C. Looman, and T. Drive, "Finite Elements for Thermoelectric Device Analysis in ANSYS."

## Author's publications

- Pub. 1 ANČÍK, Z.; TOMAN, J.; VLACH, R.; HUBÍK, V. Modeling of Thermal Phenomena in Liquid Cooling System for Aircraft Electric Unit. IEEE Transactions on Industrial Electronics, 2012, roč. 2011, č. 99, s. 1 (1 s.). ISSN: 0278-0046.
- Pub. 2 HADAŠ, Z.; VETIŠKA, V.; ANČÍK, Z.; ONDRŮŠEK, Č.; SINGULE, V. Development of energy harvester system for avionics. In Proceedings of SPIE Smart Sensors, Actuators, and MEMS VI. 8763. Bellingham, Washington, USA: SPIE, 2013.s. 87631F- 1 (87631F-8 s.)ISBN: 978-0-8194-9560- 0.
- Pub. 3 JANÁK, L.; ANČÍK, Z.; HADAŠ, Z. Simulation Modelling of MEMS Thermoelectric Generators for Mechatronic Applications. In Mechatronics 2013 Recent Technological and Scientific Advances. Springer, 2013. s. 265-271. ISBN: 978-3-319-02293- 2.
- Pub. 4 ANČÍK, Z.; VLACH, R.; JANÁK, L.; KOPEČEK, P.; HADAŠ, Z. Modeling, simulation and experimental testing of the MEMS thermoelectric generators in wide range of operational conditions. In Proceedings of SPIE Smart Sensors, Actuators, and MEMS IV. 8763. Bellingham, Washington, USA: SPIE, 2013. s. 87631M- 1 (87631M-10 s.)ISBN: 9780819495600.
- Pub. 5 JANÁK, L.; HADAŠ, Z.; ANČÍK, Z.; KOPEČEK, P. Simulation of Power Management Electronics and Energy Storage Unit for MEMS Thermoelectric Generator. In Proceedings of the 11th European Conference on Thermoelectrics. Cham Heidelberg New York Dordrecht London: Springer International Publishing, 2014. s. 189-195. ISBN: 978-3-319-07331- 6.
- Pub. 6 ANČÍK, Z.; HADAŠ, Z.; VLACH, R.; JANÁK, L.; SINGULE, V.; PROCHÁZKA, P. Simulation Modelling of MEMS Thermoelectric Generator for Aircraft Applications. In 16th INTERNATIONAL POWER ELECTRONICS AND MOTION CONTROL CONFERENCE AND EXPOSITION (PEMC 2014). 1. Antalya: Gazi University, Turkey, 2014. s. 265-270. ISBN: 978-1-4799-2062- 4.

- Pub. 7 JANÁK, L.; ANČÍK, Z.; HADAŠ, Z. Thermoelectric Generator Based on MEMS Module as an Electric Power Backup in Aerospace Applications. *Materials Today: Proceedings*, 2015, roč. 2, č. 2, s. 865-870. ISSN: 2214- 7853.
- Pub. 8 E. Navarro-Peris, J. M. Corberan, and Z. Ancik, "Evaluation of the potential recovery of compressor heat losses to enhance the efficiency of refrigeration systems by means of thermoelectric generation," *Appl. Therm. Eng.*, vol. 89, pp. 755–762, Oct. 2015.